



## **Chiller Plant System Performance**

Energy costs continue to play an important role in the decisionmaking process surrounding building design and operation. The yearly energy cost of building operation can be an important factor in building design or retrofit. Thus, there is an interest in energy efficiency. And, with this interest, comes a proliferation of new system designs and system modifications intended to save energy.

How does a designer know if a new system type will work as described? Will it save as much in all buildings as it did in the case study example? How are these systems tested?

One positive way to answer these questions is to actually build the building, install the system and monitor its performance. However, to avoid the obvious risks of this approach, it is necessary to rely on experience and system modeling. While experience is an extremely valuable tool and should always be used to its fullest extent, system modeling can play an equally valuable role by allowing the designer to gain knowledge in areas where he or she has limited experience.

This issue of the **Engineers Newsletter** reviews a few common chiller system optimization schemes using the Trane TRACE® Ultra program as an analysis tool. Specifically, the schemes described here involve:

- Lowering tower water temperature to increase chiller efficiency.
- "Decoupling" the chillers from the chilled water distribution loop.
- Using unequally sized chiller combinations.

These particular modifications were not chosen because they are on the forefront of chiller system enhancements, nor are the examples included here intended to promote . . . or to prove or disprove the validity of . . . one system enhancement over another. Each of the modifications described here has been used in a variety of building systems with good results.

Rather, they were chosen to promote the use of building simulation as a method of reviewing chiller system enhancements. Therefore, view this newsletter as a "means" rather than an "end."

### **The Method**

It is important to recognize the interaction between the various components of a system when optimizing. In some instances, increased efficiency or the reduced cost of a particular component come at the expense of other components in the system. An example of this tradeoff is low temperature air distribution. Although the air distribution system delivers less flow and consumes less energy, the chillers are forced to operate at a less efficient point to produce this low temperature, thereby offsetting the savings to some extent.

The difficulty in determining the total system efficiency change, due to the alteration of any one component, is the large number of variables that affect buildings. Building size, weather, interior loads, division in zones, etc., all impact the results. The challenge is to keep track of the many variables involved and their affect on the system. System enhancements that work for one building may or may not work for another. To avoid installing systems that do not perform as expected, the designer should run an analysis for each building to compare alternatives. Using a building simulation program simplifies this task.

A word of warning: Building simulation programs are an important tool, but must be used carefully. A person familiar with the program and the interrelationships of the components could develop a building, load profile and environment that would prove either an advantage or disadvantage, depending on his intent, to any type of component change.

System efficiency improvements must also be weighed against other factors. Systems that are costly to install or are overly complicated may not be worth the extra efficiency. Conversely, a system that only saves a small amount of energy or cost, but simplifies control or design, may be justified.

#### The Building

A model reflecting the actual building in as many ways as is possible provides the best means for determining the actual increase in system efficiency afforded by any enhancement . . . or combination of enhancements . . . of the system components.

To demonstrate the use of TRACE Ultra in analyzing the effects of system alterations, an arbitrary building was developed. Standard building default values for an office building were used, Table 1. The building was sized to provide an approximate peak load of 1000 tons and incorporated a VAV all-air distribution system. Located in Los Angeles, this resulted in a 13-story building with a total of 531,700 square feet. HVAC equipment used includes centrifugal chillers and a floor-by-floor, fan-powered variable air volume system.

A breakdown by energy consumption is shown in Figure 1. The figure shows that most of the energy consumed, 52 percent, is used for lighting while the next largest percentage, 20 percent, is used by the chiller system. The chiller system power consumption, Figure 2, includes the centrifugal chillers, 51 percent; tower fans, 6 percent; chilled water pump, 24 percent; and condenser water pump, 19 percent.

**Table 1: Building Specifications**

Chillers	Centrifugal
Air Side	FPVAV, Climate Changer® per floor
Zoning	15-foot perimeter per side, one central per floor
Inside Conditions	78 F/30% RH
People	100 square feet per person
Lighting	2 watts per square foot
Outside Air	15 cfm per person, minimum
Miscellaneous Load	0.5 watts per square foot
Economizer	On point, 60 degrees
U Values	Roof = 0.08; Wall = 0.10
Glass	30%, U = 0.55
Thermostats	Shading coefficient = 0.56
	On from 7 a.m. to 6 p.m.

**Figure 1:**  
Total Building Energy Consumption

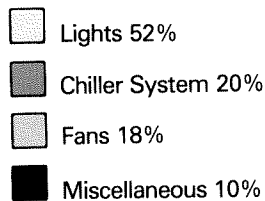
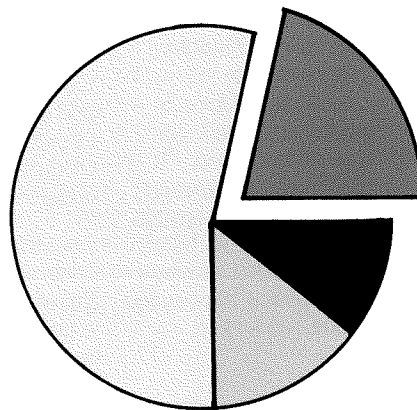

**Figure 2:**  
Chiller System Power Consumption

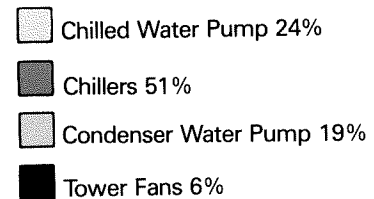
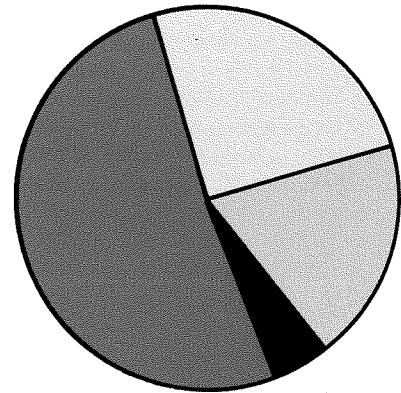
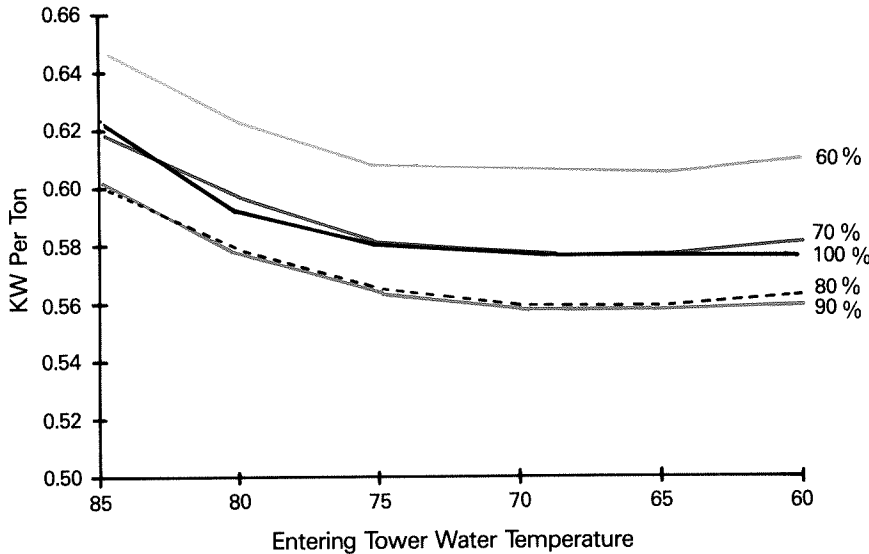



Figure 3: KW Per Ton vs Tower Water Temperature



### The Enhancements

#### Tower Relief

The first change made to this system model was to allow the condenser water temperature to drop whenever ambient conditions permitted. Lowering the water temperature lowers the head pressure on the compressor, resulting in a higher chiller efficiency. The energy consumed by a chiller is primarily used by the compressor to move gas from the low pressure in the evaporator to the high pressure in the condenser. As the pressure differential between the evaporator and the condenser increases, more work is required by the compressor. Lowering the tower water temperature lowers this pressure differential, resulting in less work (kw) expended per ton of cooling.

While it is true that lowering condenser water temperature improves efficiency, there are some practical limitations. These limitations fall into two categories: operational problems and efficiency limitation. On the operational side, a minimum pressure differential must be maintained between the evaporator and condenser to assure adequate refrigerant flow through the refrigerant metering system and to maintain proper oil movement within the chiller. When this minimum is violated, insufficient refrigerant is returned to the evaporator, causing low refrigerant temperature tripouts and oil is lost to the refrigerant.

In addition, the lack of refrigerant in the evaporator affects the efficiency of the chiller. As the liquid refrigerant level in the evaporator drops, some of the tubes are uncovered, decreasing the amount of heat transfer surface area. Chiller efficiency will actually begin to decrease if tower water temperature drops too far, as shown in Figure 3. The point of maximum efficiency and the shape of the curve will vary with machine selection and load conditions.

The reduction in tower water temperature comes from an increase in tower fan energy consumption. When a tower is set to produce 85 F water, there will be times of the year when the fans do not have to run to maintain this temperature. Conversely, when the tower is set to produce 65 F water, there will be times when the fans will be running at full load and still be unable to produce the 65 F water.

TRACE runs were made at 85, 75, 65 and 55 F tower settings by setting the minimum tower temperature in the equipment section of the program. The program monitors outside air dry and wet bulb temperatures and runs the fans as needed to meet the specified water temperature. When ambient temperature prevents the tower from meeting its setpoint, the fans continue to operate. This models the typical operation that would occur if the tower thermostat were set to the desired minimum temperature.

Figure 4: Chiller And Tower KWH vs Tower Temperature

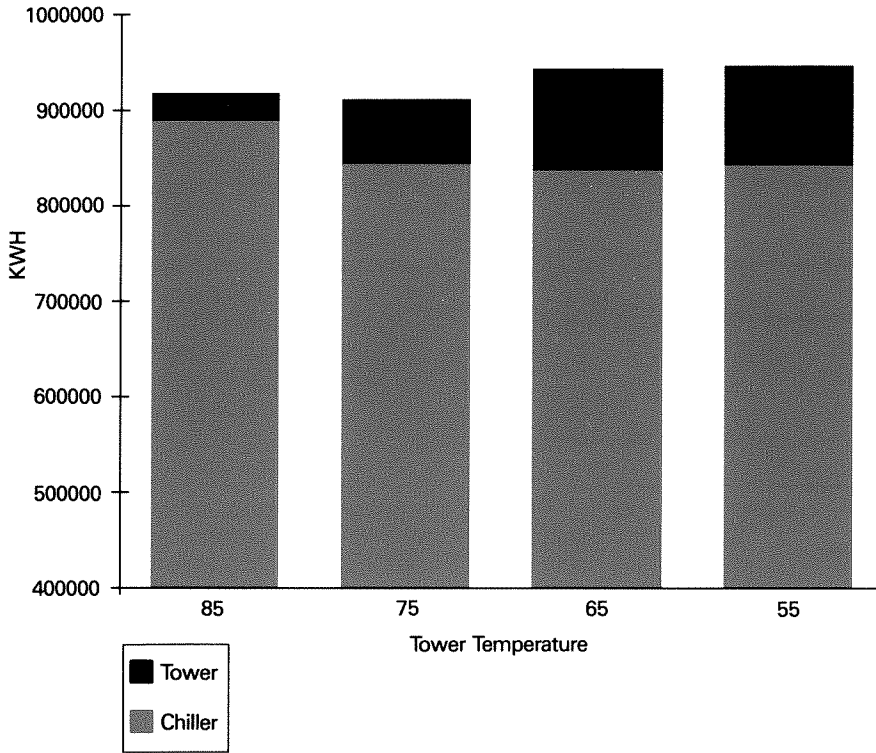

Figure 4 shows the combined energy consumption of the chillers and towers for the various tower water temperature settings. From 85 degrees to 65 degrees the chiller power consumption drops and the fan power consumption increases. Chiller power consumption increases slightly at 55 degree tower water temperature as we would expect from Figure 3. At 65 degrees, the additional power required by the fan overwhelms the savings in the chiller. Thus, the combined power consumption reaches a low at 75 degrees.

**Decoupled Chilled Water Piping**

The second enhancement made to the system model was to decouple the chilled water production loop from the distribution loop. Applying the principle of variable air volume (VAV) on the air side, decoupling the chilled water system allows the chilled water flow to the building cooling loads to fluctuate based on demand.

In the standard chilled water system, the flow of chilled water through the chillers and to the loads is constant. At part load, the excess chilled water sent to the coils is circuted around the coils using three-way valves. Thus, a portion of the water was chilled, pumped out to the loads, bypassed around the loads, mixed with the warm water exiting the coil and returned to the chillers.

The decoupled piping system allows the load-side "distribution" loop to seek its optimum operating flow rate independent of the flow through the chillers "production" loop. Flow through the distribution loop will modulate based on load, while the flow in the production loop follows discrete steps dictated by the design flow requirements of the chillers.

To modulate flow based on demand, the coils serving the cooling loads are fitted with two-way valves that modulate flow based on the needs of the loads. At part load, less water is pumped around the distribution loop, saving pump horsepower. The pump supplying these coils must be able to accommodate the resulting flow

variations. Chiller controls, however, cannot handle the wide fluctuations in flow that the system is likely to produce. To provide constant water flow through the chillers and variable water flow through the loads, each of the chillers has its own chilled water pump and the chillers and loads are "decoupled" by adding a crossover pipe between the supply and return lines, as shown in Figure 5. Decoupling the chilled water system makes the flow through the chillers independent of the flow through the loads. The actual chilled water is common to both loops, but the loops can run independently.

Figure 5: Decoupled Chilled Water Piping

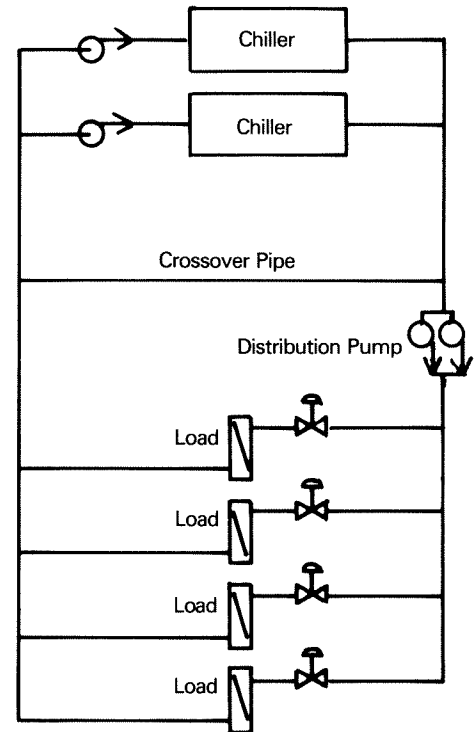

The decoupled system was simulated by tying a chilled water pump to each of the two chillers. These chiller pumps were sized to accommodate the pressure drop of the respective chillers. A variable speed system pump was also added. It was sized to accommodate the pressure drop of the distribution piping and loads. The power consumption of the system pump was tied to the load.



Figure 6 provides a comparison of the pump power consumption for single and two-chiller (two-pump) standard systems and a two-chiller decoupled system. The results of this run indicate a decrease in pump power consumption of about nine percent. While this is a significant saving in power consumption, the savings may be offset by the expense of multiple pumps. However, this is one case where there are other benefits provided by the system enhancement that should be considered. These include:

**Decreased Piping Cost:** Chilled water distribution piping can be sized based on "block loads" rather than the sum of the peak cooling coil loads.

**Constant Return Water Temperature:** The two-way valves on the distribution loop regulate water flow through the coils to meet the design leaving air temperature. Thus, the water leaving the coils will always be at or near design temperature. This eliminates the need for chilled water reset in most systems.

**Constant Supply Water Temperature:** The production loop is set to supply a fixed chilled water temperature to the distribution loop. The chiller controls modulate chiller capacity to maintain a constant temperature under all load conditions. And there is no dilution of chilled water with unchilled water from nonoperating chillers. The result is a constant chilled water supply temperature over the entire load range.

**Simplified Chiller Sequencing:** Flow through the bypass pipe is a direct indication of the flow relationship between the production and distribution loops. Since the flows are a direct indication of building load, chiller sequencing decisions can be made by monitoring the direction and quantity of flow in the crossover pipe.

**System Flexibility:** As a result of the modular design of decoupled systems, expansion of the existing system production and distribution loops can be accomplished without disturbing the original system components.

**System Adaptability:** Decoupled systems can be used in conjunction with all the variations of chilled water systems, such as thermal storage, heat recovery and free cooling.

Figure 6: Pump Power Consumption vs System Type

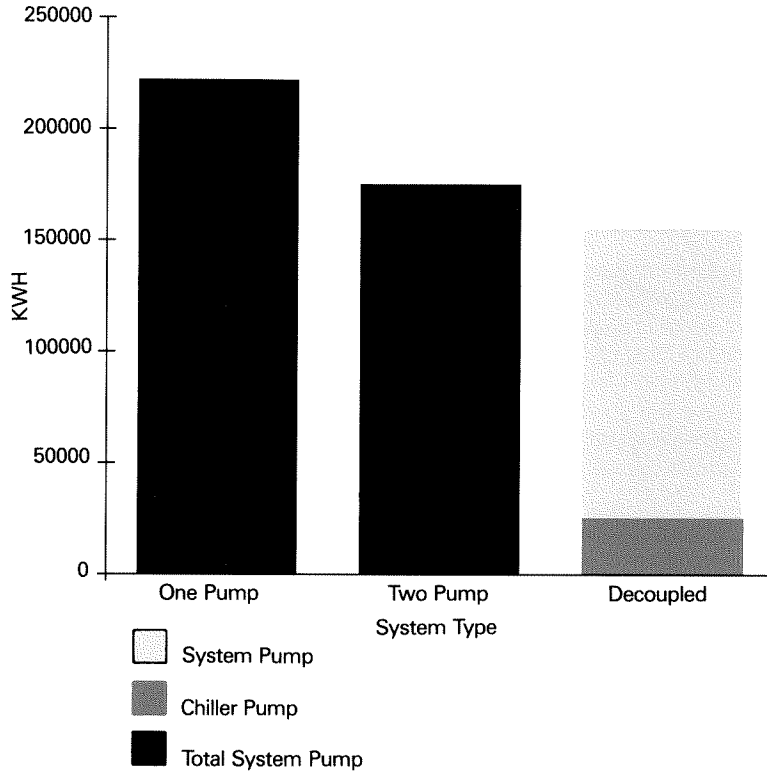

Figure 7: Chiller Part-Load Efficiency

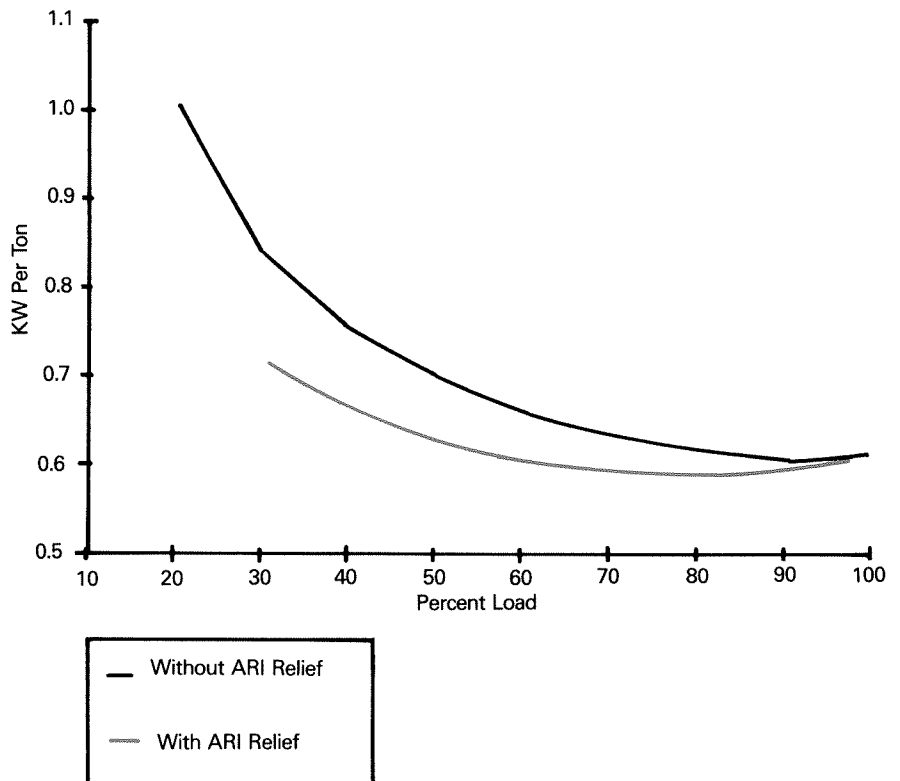
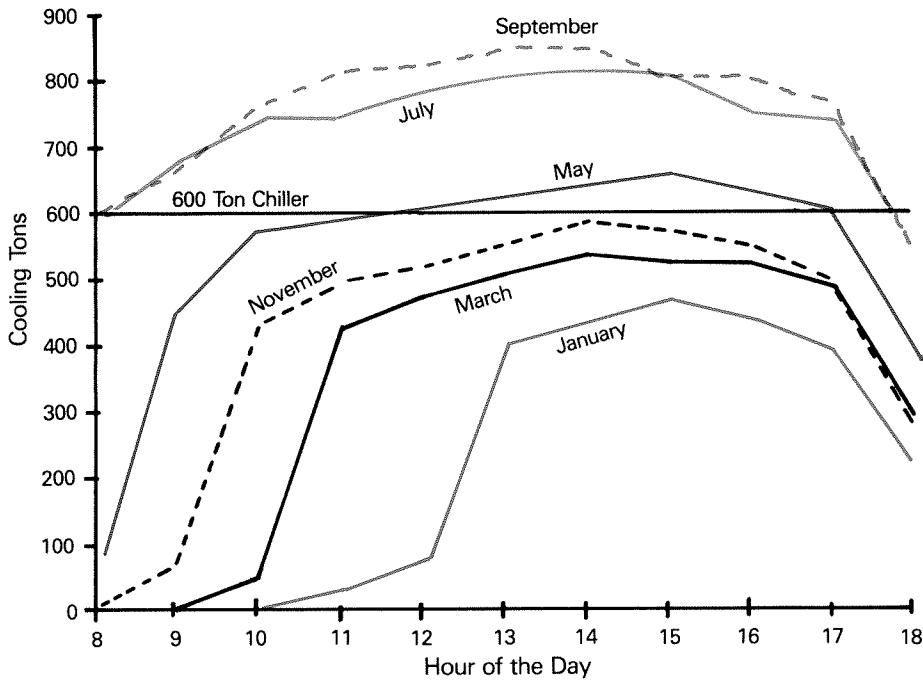

Figure 8: Monthly Cooling Load — L.A.



**Equal Or Preferential Chiller Loading:**

Chillers can be equally loaded or preferentially loaded, i.e. heat recovery, by their placement in relation to the crossover pipe.

**Chiller Size And Sequence**

The final enhancement made to the system model was an attempt to take advantage of the variation of chiller efficiency over its load range. Most chillers have an optimum point of operating efficiency that is approximately 80 percent of maximum capacity, although this optimum point varies from chiller to chiller and with tower water temperature, Figure 7. On either side of this point, the efficiency begins to drop. The sizing and sequencing of the chillers should affect the power consumption of the system.

Two methods of chiller sequencing were simulated: swing and standard. A "swing" chiller arrangement uses one small chiller with one or more large ones. The chillers are sequenced so that the small chiller is started first. It handles the loads from the system minimum to the small chiller's maximum capacity. Once the small chiller's maximum capacity is exceeded, it is shut down and one of the larger chillers is restarted. This assures that enough load is supplied to the larger chiller so that it is operating within its maximum efficiency range. The larger chiller carries the load until its maximum capacity is reached, at which point the smaller chiller is started. As the load increases beyond the capacity of small and large chillers combined, the small chiller is stopped and the second large chiller is started. The unloading process follows the same logic, only in reverse order.

The "standard" method starts and fully loads the first chiller. Once the second chiller is started, both chillers continue to operate at equal percentages to meet the

load. Additional chillers are added in the same manner. As the load decreases, chillers are cycled off in the reverse order that they were added, first on-last off.

Water pumping and cooling tower energy consumption must also be accounted for when making sequencing decisions. As the chillers are sequenced on and off, so are the associated water pumps and tower capacity control. From the viewpoint of system energy consumption, it is generally better to leave a chiller on past its point of maximum efficiency than to changeover and start a larger chiller and its associated pumps.

Chillers can be sized by plotting the building's load profile, then choosing chiller sizes that will cover the bulk of the operating hours. Figure 8 shows the load profile for the example building. This load profile is a graphic representation of the load output section of the TRACE program. For clarity, only weekday loads for alternating months are shown on the plot. The plot indicates that the cooling requirements for most operating hours fall between 400 and 600 tons.

TRACE Ultra runs were made using one 1000-ton, two 500-ton, 400/600-ton and 300/700-ton chiller combinations. Figure 9 compares the four systems using "swing" sequencing. The comparison includes power consumption for the tower fans, chilled water pumps and condenser water pumps along with the chillers. There are a number of interesting observations that can be made about this comparison. First, the total system energy consumption does drop as the size difference between the chillers increases, although the drop from 400/600 to 300/700 is very slight.



Figure 9: Chiller Size Combination vs Power Consumption

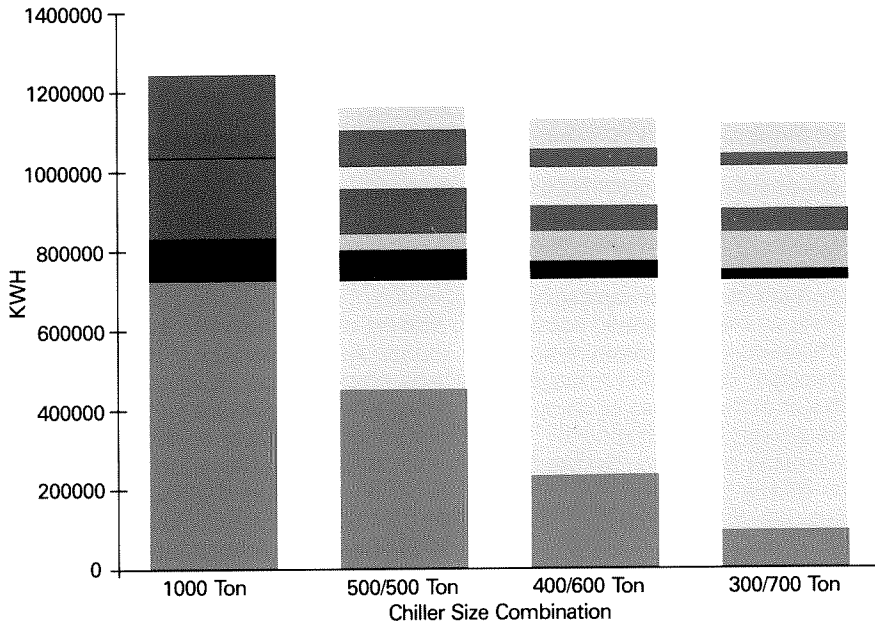

The second interesting point is the chiller-only power consumption. All of the chiller combinations draw nearly the same amount of power. This is the result of the load profile for the example building. Since the chiller plant seldom serves light loads, all of the chillers operate in their high efficiency range most of the time. The savings in total efficiency are due to the auxiliary equipment.

An additional run was made with the 400/600 and 300/700 ton chiller combinations to show the effect of "swing" versus "standard" chiller sequencing alternatives. Figure 10 shows that there is an advantage to the "swing" method in items of total system energy consumption, but not from the standpoint of chiller efficiency.

**Summary**

System modeling using a building simulation program can provide significant benefits. These include analysis of new system concepts as well as refinement of common systems. Most importantly, they allow the designer to match systems to a specific building, thereby reducing the risk of relying on examples and case studies.

Figure 10: Swing vs Sequenced Chiller Control

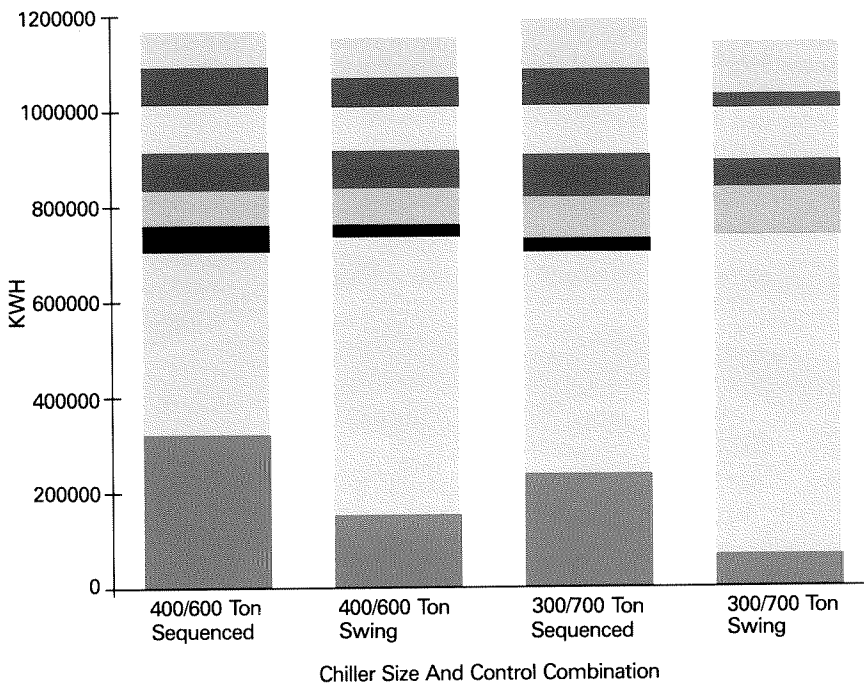

Although energy usage is becoming an increasingly important factor in the building design decision process, it should not be the sole consideration. Some system enhancements may offer benefits far beyond any energy savings they may net, while others may save considerable energy by sacrificing the simplicity of the control scheme. Consequently, the designer must use all the "tools" at his disposal to properly evaluate the total picture when making design decisions.

- Condenser Pump 2
- Condenser Pump 1
- Chilled Pump 2
- Chilled Pump 1
- Tower 2
- Tower 1
- Chiller 2
- Chiller 1

Correction: The equation on page 1 of the Engineers Newsletter, Vol. 18, No. 1, contained an error.

$$IPLV \text{ or } APLV = 0.1(A + B)/2 + 0.5(B + C)/2 + 0.3(C + D) + 0.1D \text{ (Equation 1)}$$

should be

$$IPLV \text{ or } APLV = 0.1(A + B)/2 + 0.5(B + C)/2 + 0.3(C + D)/2 + 0.1D \text{ (Equation 1)}$$