



Product Catalog

DCHC

Horizontal Concealed Chilled Water Fan Coil
with DCBL Motor Airflow: 180~2380 m³/h

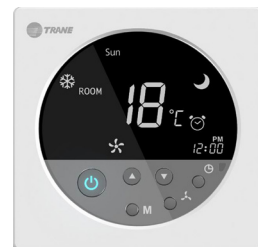
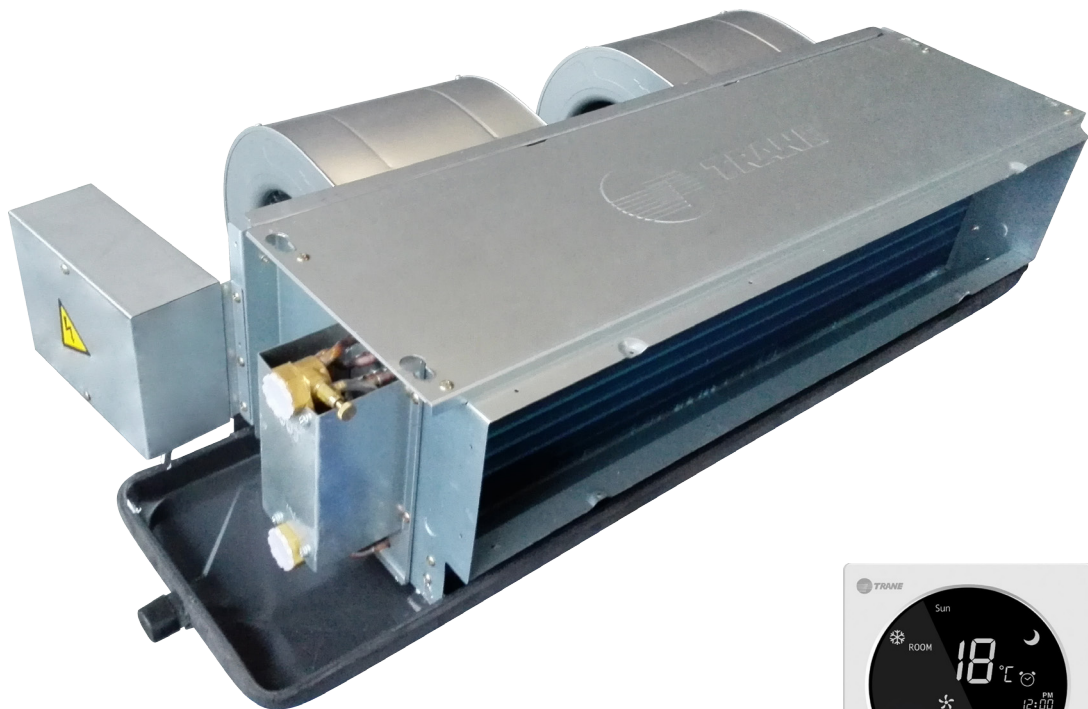



Table of Contents

Product Features	3
Product Benefits	4
Model Number Descriptions	6
Performance Data	7
Airflow Curves	13
Dimensions	17
Wiring Diagrams	19

Product Features

DCHC, with premium comfort and energy efficiency, is the latest generation of DCBL fan coil product developed by Trane Company. The product uses the latest DCBL motor stepless speed control technology, PI temperature control methodology, high efficiency low sound and vibration fan technology, and high efficiency heat exchanger with small diameter tube technology, to achieve quiet, comfort, energy saving, environmental friendly, safe and reliable, etc. benefits.

Rich Offerings

9 unit sizes, airflow range 180~2380CMH, able to meet various building size capacity requirements. Multiple ESP's, 12Pa/30Pa/50Pa/62Pa/75Pa/88Pa/100Pa/112Pa, able to meet jobsite various duct system resistance requirements.

EarthWise Coil (Option)

Offer 3 rows, 4 rows, dedicated for high delta-T system application to optimize overall system performance.

High Efficiency Coil

Coil is designed with multi-row small diameter copper tubes, together with high efficiency louver fin with hydrophilic coating, the optimum heat exchange efficiency is achieved, in the mean time the condensation carryover is prevented and the anti-corrosion capability is improved. Coil is also designed with counter-flow circuitry, thus the heat exchange efficiency is maximized.

Low Noise Fan

Large diameter forward-curve multi-blade centrifugal fan, with the fan wheel statically and dynamically balanced, to ensure stable and quiet operation, as well as even airflow distribution. Fan wheel hub with rubber isolation, to minimize the shocking load from unit start-up and varying load, thus reducing unit vibration and noise level.

Condensation-Free

One-piece stamping integral type drain pan, without any seam or joint, eliminating leakage or condensation risk. Drain pan is externally lined with one-piece integral type insulation, without any patch or screw attachment, good insulation and aesthetic appearance, while eliminating condensation or corrosion risk. Drain pan is internally designed with different height bracket at each end, to ensure drain pan with a positive slope angle after unit installation, thus guarantee condensate water drained out freely.

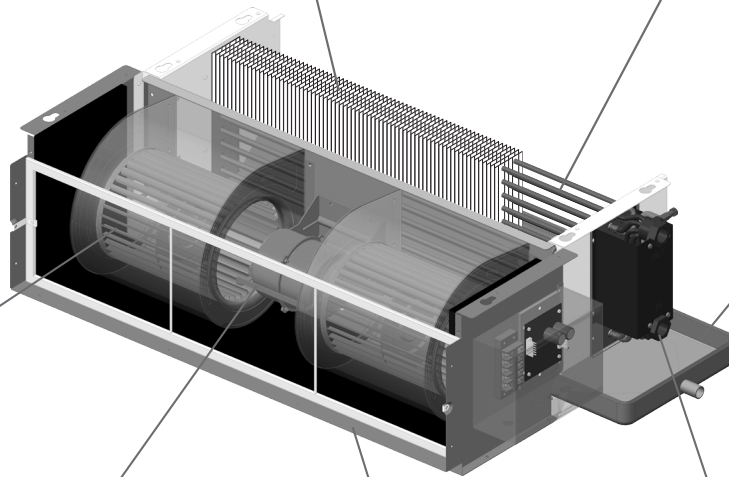

Brushless DC Motor

Every unit is equipped with standard DCBL motor, which is Trane newly designed high efficiency brushless DC motor, capable of true stepless fan speed control (1rpm increment). Compared with traditional AC motors, average energy consumption at high speed could be reduced by more than 40%. Motor with IP42 protection grade and class B insulation, thus ensuring high motor reliability and a long service life.

Quiet Structure

Unit casing structure is well engineered with optimum airflow tunnel design, as well as multiple casing sheet metal parts are lined with insulation having good thermal resistance and sound attenuation, to ensure smooth airflow and low unit sound.

Easy Maintenance

Return air plenum is Trane patented design. With no need to remove the whole return air plenum, the fan-motor subassembly could be easily disassembled from the unit, to ease of fan and motor maintenance, as well as coil cleaning.

Easy Installation

Coil water inlet and outlet headers are designed as hexagon shape, to ease of using wrench from multiple angles, convenient for water pipe connection, thus reducing installation time and labor cost.

Smart Control

Every unit is equipped with TM smart thermostat, which uses PI temperature control methodology, able to realize fast cooling or heating at beginning, and precise temperature control (within $\pm 0.5^{\circ}\text{C}$) at stable condition. Thermostat casing is Trane patented design with aesthetic appearance, and has multiple color choices to perfectly fit in the indoor decoration.





Product Benefits

Efficient

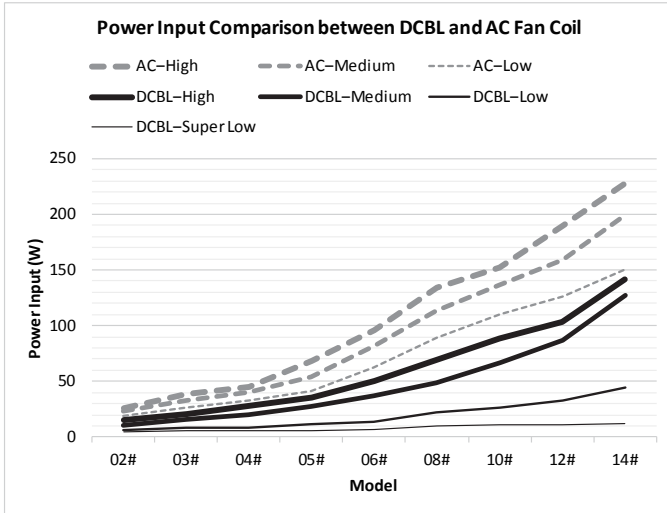

Traditional AC PSC motor efficiency is only about 40%, while DCBL motor efficiency can be above 70%.

DCBL fan coil power consumption is significantly reduced comparing to AC fan coil. Average power consumption could be reduced by more than 40% at high and medium speed, and up to 70% reduction at low speed. DCBL fan coil power consumption at high speed is even lower than AC fan coil at low speed.

DCBL motor has a very wide range of speed operation, thus able to maximize the benefit of energy saving. For example, when the room load is low during night operation or transition season, at auto fan speed mode, DCBL motor could run slowly to super low speed, the unit power consumption is as low as only a few watts.

Quiet

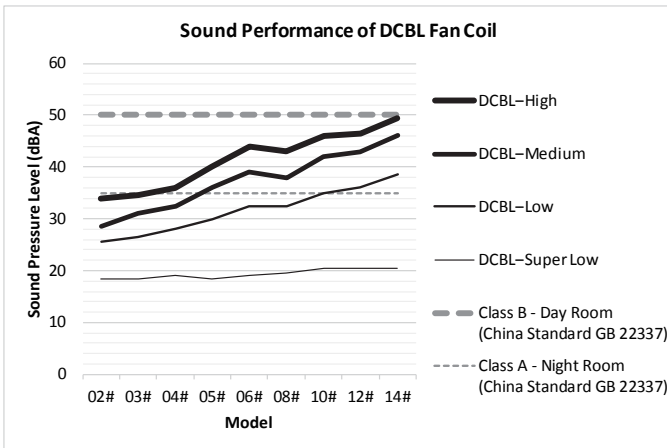

Note: Refer to China Standard GB 22337, Emission Standard for Community Noise:

Class A room is mainly used for sleep, needs to be quiet at night, including residential bedroom, hospital ward, hotel room, etc.

Class B room is mainly used in the day, for thinking and concentration, or for normal speech without interference, including school classroom, conference room, office, non-bedroom residential room, etc.

With large diameter wheel, and wheel hub with rubber isolation design, the unit vibration and noise levels are minimized.

With permanent magnet rotor DCBL motor and without hall sensor, the carbon brush noise from traditional DC motor is avoided.

With ultra high frequency sine wave PWM signal, which is beyond human ear perception, to control motor, very smooth motor running is achieved, and average unit noise level is reduced by 1 dBA comparing to AC motor fan coil.

DCBL motor has a very wide range of speed operation, thus able to maximize the benefit of quiet operation. For example, when the room load is low during night operation or transition season, at auto fan speed mode, DCBL motor could run slowly to super low speed, the unit noise level is as low as 20 dBA.

Comfort

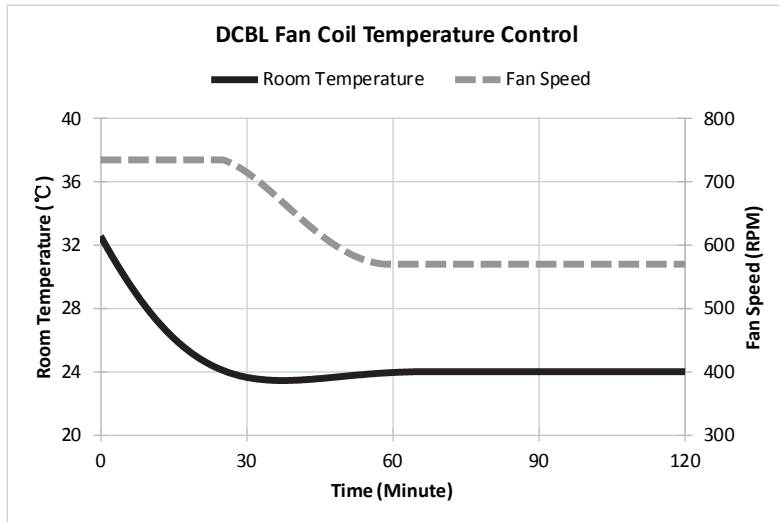

With the DCBL motor controlled by sine-wave PWM signal, fan speed regulating precision can reach 1 RPM.

With PI temperature control methodology, together with stepless fan speed control, fast cooling or heating can be realized to make indoor environment comfortable at a very short period, as well as the room temperature can be precisely controlled within $\pm 0.5^{\circ}\text{C}$ at stable condition.

Smart

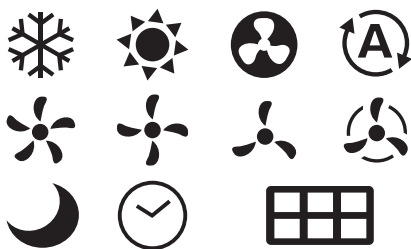

Big LCD screen thermostat, with square casing and round display, classic appearance, cool background light, suitable for noble and elegant decoration. Thermostat casing even has multiple color choices to perfectly fit in the indoor decoration.

With powerful functions, smart control and convenient operation, thermostat can realize:

- Room temperature setting and display.
- Cooling, heating, ventilation and auto mode.
- High, medium and low fan speed mode, as well as auto fan speed (stepless control).
- Water valve control.
- Real-time display.
- Timer switch (auto power on/off).
- Sleep mode:
(Under cooling mode, the setting temperature will automatically increase 1 degree after 3 hours, increase extra 1 degree after 6 hours, and reset to original setting temperature after 10 hours. Under heating mode, the setting temperature will automatically decrease 1 degree after 3 hours, decrease extra 1 degree after 6 hours, and reset to original setting temperature after 10 hours.)
- Memory function for power-down protection.
- Failure display.
- Anti-freeze protection.

The thermostat along with every unit has been factory set with unit model and ESP type, which could also be set by key combinations in the jobsite, thus more convenient operation.

Network type thermostat is equipped with RS485 port supporting standard Modbus communication protocol, not only can network with group controller to realize zone central control, but also can network with building automation system (BAS) to realize remote monitor and control.



Model Number Descriptions

D C H C 0 2 L 3 0 1 1 0 B 0 A 0 1 A T
 -
 1 2 3 4 5 6 7 8 9 10 11 12 13 14 15 16 17 18 19

Digit 1-4: Model Name
 DCHC = DCBL Fan Coil Horizontal Concealed Unit

Digit 5-6: Size / Nominal Airflow
 02 = 340 CMH 08 = 1360 CMH
 03 = 510 CMH 10 = 1700 CMH
 04 = 680 CMH 12 = 2040 CMH
 05 = 850 CMH 14 = 2380 CMH
 06 = 1020 CMH

Digit 7: Connection Side
 L = Left Connection R = Right Connection

Digit 8: Coil Rows and Applications
 2 = 2 Rows (Normal Application, Size 02~08)
 3 = 3 Rows (Normal Application)
 4 = 4 Rows (Normal Application)
 C = 3 Rows (EarthWise Application)
 D = 4 Rows (EarthWise Application)
 H = 3 rows hi-capacity (EarthWise)
 6 = 2 rows, [2.5MPa]
 7 = 3 rows, [2.5MPa]
 8 = 4 rows, [2.5MPa]
 R = 3 rows (EarthWise), [2.5MPa]
 S = 4 rows (EarthWise), [2.5MPa]
 W = 3 rows hi-capacity (EarthWise), [2.5MPa]

Digit 9: Electric Heater
 0 = No Electric Heater
 1 = Electric Heater (w/ Relay in Terminal Box)

Digit 10: Motor Type
 1 = DCBL Motor - ESP 12Pa
 3 = DCBL Motor - ESP 30Pa
 5 = DCBL Motor - ESP 50Pa
 A = DCBL Motor - HESP 100Pa

Digit 11: Voltage/Hertz/Phase
 1 = 220~240VAC/50Hz/1Ph
 2 = 220~240VAC/60Hz/1Ph

Digit 12: Valve Package
 0 = None

Digit 13: Thermostat
 N = DCBL Network Thermostat (TM83)
 G = DCBL Network Thermostat (TM83), w/ 8m wire
 0 = No Thermostat, for 1 DCBL Thermostat to Control 2 Units (Size 02~06)
 L = Three-Speed Module, w/ AC LCD Thermostat (TM50)
 T = Three-Speed Module, Support 3-Speed Control
 V = Variable-Speed Module, Support 0-10V Control

Digit 14: Plenum Filter
 0 = None
 A = Rear Return Air Plenum
 B = Rear Return Air Plenum w/ 6mm Nylon Filter
 C = Rear Return Air Plenum w/20mm AI Filter
 D = Bottom Return Air Plenum
 E = Bottom Return Air Plenum w/6mm Nylon Filter
 F = Bottom Return Air Plenum w/20mm AI Filter

Digit 15: Drain Pan
 A = Cold-roll Steel, PE Insulation
 B = Cold-roll Steel, PE Insulation, +200mm
 C = Cold-roll Steel, PE Insulation, +310mm
 D = Stainless Steel, PE Insulation
 E = Stainless Steel, PE Insulation, +200mm
 F = Stainless Steel, PE Insulation, +310mm
 G = Cold-roll Steel, Non-flammable Insulation
 H = Cold-roll Steel, Non-flammable Insulation, + 200mm
 J = Cold-roll Steel, Non-flammable Insulation, + 310mm
 K = Stainless Steel, Non-flammable Insulation
 L = Stainless Steel, Non-flammable Insulation, + 200mm
 M = Stainless Steel, Non-flammable Insulation, + 310mm

Digit 16: Humidifier Option
 0 = No Humidifier Option

Digit 17: Design Version
 1 = Frist Design

Digit 18: Region
 A = API

Digit 19: Factory Edition
 T = Thailand



Performance Data

3 Rows Unit (2-Pipe)

Unit Size			DCHC02	DCHC03	DCHC04	DCHC05	DCHC06	DCHC08	DCHC10	DCHC12	DCHC14	
Airflow	m ³ /h	High	340	510	680	850	1020	1360	1700	2040	2380	
		Medium	280	410	550	690	830	1100	1360	1630	1900	
		Low	180	270	350	440	520	690	860	1020	1190	
Normal Application	Cooling Capacity	kW	High	2.21	3.16	4.17	5.06	6.10	8.00	9.30	11.10	13.00
	Heating Capacity	kW	High	3.50	5.20	6.70	8.12	9.70	13.00	15.50	18.00	20.80
	Water Flow Rate	l/s	High	0.11	0.15	0.20	0.25	0.30	0.39	0.45	0.53	0.63
	Water Pressure Drop	kPa	High	25	24	25	30	40	35	35	40	50
EarthWise Application	Cooling Capacity	kW	High	2.21	3.14	3.99	5.02	6.10	7.98	9.85	11.31	13.29
	Heating Capacity	kW	High	3.37	4.84	6.32	7.56	9.16	12.27	14.92	17.15	19.95
	Water Flow Rate	l/s	High	0.07	0.10	0.12	0.16	0.20	0.24	0.29	0.34	0.40
	Water Pressure Drop	kPa	High	29	22	17	29	40	33	36	35	50
High Capacity EarthWise Application	Cooling Capacity	kW	Medium	-	2.06	2.70	3.39	4.20	5.41	6.53	7.49	8.87
	Heating Capacity	kW	Medium	-	3.61	4.73	5.93	7.35	9.47	11.43	13.11	15.52
	Water Flow Rate	l/s	Medium	-	0.06	0.08	0.11	0.12	0.16	0.19	0.22	0.27
	Water Pressure Drop	kPa	Medium	-	28	20	30	22	40	35	35	48
Electric Heater	Heating Capacity	kW	High	0.50	1.00	1.40	1.60	1.80	2.80	3.20	3.60	4.60
Power Input	12Pa	W	High	15	21	28	35	50	69	89	103	142
			Medium	11	16	20	28	37	48.5	66.5	87	127
			Low	6.5	8	9	12	14	22.5	26	32.5	45
			Super Low	4	4.5	4.5	5	5.5	9	9.5	10	10.5
	30Pa	W	High	20	30	37	47	63	84	106	122	167
			Medium	16.5	23.5	32	39.5	51	70.5	85.5	107.5	146.5
			Low	9	12.5	15.5	19	20	29.5	37	41.5	52
			Super Low	4	4.5	4.5	5	5.5	9	9.5	10	10.5
	50Pa	W	High	28	42	50	60	77	103	127	156	200
			Medium	22.5	33	45	52.5	60.5	85.5	113	130	172.5
			Low	12.5	17	23.5	27	29	42	56	59	70.5
			Super Low	4	4.5	4.5	5	5.5	9	9.5	10	10.5
Sound Pressure Level	12Pa	dBA	High	34	34.5	36	40	44	43	46	46.5	49.5
			Medium	28.5	31	32.5	36	39	38	42	43	46
			Low	25.5	26.5	28	30	32.5	32.5	35	36	38.5
			Super Low	18.5	18.5	19	18.5	19	19.5	20.5	20.5	20.5
	30Pa	dBA	High	38	38.5	40.5	43	45.5	45.5	48.5	49.5	51
			Medium	32.5	36.5	38.5	40	43.5	43	45.5	46.5	48.5
			Low	30.5	34	35.5	38	39	39	43	44	46
			Super Low	19	18.5	18.5	19	18.5	19	20.5	21	21
	50Pa	dBA	High	41	42	44	45	46.5	48	50.5	51	53
			Medium	35	38.5	40	43	42.5	46	48	48	50.5
			Low	33.5	37	38.5	41	40.5	43.5	46	45.5	47.5
			Super Low	18.5	18	17.5	19	18.5	19	20	20	20.5
Net Weight	Without Plenum	kg	12	15	16.5	17.5	20.5	29	32	35.5	38	
	With Rear Plenum	kg	15	18.5	20.5	22	25.5	35	39	43	46	
	With Bottom Plenum	kg	15.5	19	21	22.5	26	35.5	39.5	43.5	47	
Fan	Type	Brushless DC Motor										
	Quantity	1	2	2	2	2	3	4	4	4		
Motor	Type	Brushless DC Motor										
	Protection Grade	IP42										
	Insulation Class	Class B										
	Quantity	1	1	1	1	1	2	2	2	2		
Coil	Type	Copper Tube / Hydrophilic Aluminum Fin										
	Working Pressure	1.8 MPa										
Connection	Water Inlet/Outlet	Rc 3/4" (Female)										
	Condensate Outlet	R 3/4" (Male)										
Options			Return Air Plenum, Filter, Valve, Thermostat, Electric Heater, Various Drain Pans									

- Notes:**
- Airflow, cooling and heating capacities, etc. are performance data of bare unit (i.e. without return air plenum).
 - Normal Application:
 - Cooling: inlet air dry/wet bulb temperature: 27/19.5°C; chilled water inlet/outlet temperature: 7/12°C.
 - Heating: inlet air dry bulb temperature: 21°C; hot water inlet temperature: 60°C; same water flow rate as cooling.
 - EarthWise Application:
 - Cooling: inlet air dry/wet bulb temperature: 27/19.5°C; chilled water inlet/outlet temperature: 5/13°C.
 - Heating: inlet air dry bulb temperature: 21°C; hot water inlet temperature: 60°C; same water flow rate as cooling.
 - High Capacity EarthWise Application:
 - Cooling: inlet air dry/wet bulb temperature: 26.7/19.4°C; chilled water inlet/outlet temperature: 7.2/15.6°C.
 - Heating: inlet air dry bulb temperature: 21°C; hot water inlet temperature: 60°C; same water flow rate as cooling.
 - Sound pressure data are bare unit (i.e. without return air plenum) tested in semi-anechoic room according to China standard GB/T 19232.



Performance Data

2 Rows Unit (2-Pipe)

Unit Size			DCHC02	DCHC03	DCHC04	DCHC05	DCHC06	DCHC08	
Airflow	m ³ /h	High	350	520	690	870	1040	1380	
		Medium	280	410	550	700	830	1100	
		Low	180	270	350	450	520	690	
Normal Application	Cooling Capacity	kW	High	1.90	2.80	3.60	4.50	5.40	7.20
	Heating Capacity	kW	High	3.15	4.93	6.10	7.41	8.90	12.00
	Water Flow Rate	l/s	High	0.10	0.14	0.17	0.21	0.26	0.34
	Water Pressure Drop	kPa	High	15	30	25	30	34	36
Electric Heater Heating Capacity		kW	High	0.50	1.00	1.40	1.60	1.80	2.80
Power Input	12Pa	W	High	15	21	28	35	50	69
			Medium	11	16	20	28	37	48.5
			Low	6.5	8	9	12	14	22.5
			Super Low	4	4.5	4.5	5	5.5	9
	30Pa	W	High	20	30	37	47	63	84
			Medium	16.5	23.5	32	39.5	51	70.5
			Low	9	12.5	15.5	19	20	29.5
			Super Low	4	4.5	4.5	5	5.5	9
	50Pa	W	High	28	42	50	60	77	103
			Medium	22.5	33	45	52.5	60.5	85.5
			Low	12.5	17	23.5	27	29	42
			Super Low	4	4.5	4.5	5	5.5	9
Sound Pressure Level	12Pa	dBA	High	34	35	36.5	40.5	44.5	43.5
			Medium	28.5	31.5	33	36.5	39.5	38.5
			Low	25.5	27	28.5	30.5	33	33
			Super Low	18.5	19	19.5	19	19.5	20
	30Pa	dBA	High	38	39	41	43.5	46	46
			Medium	32.5	37	39	40.5	44	43.5
			Low	30.5	34.5	36	38.5	39.5	39.5
			Super Low	19	19	19	19.5	19	19.5
	50Pa	dBA	High	41	42.5	44.5	45.5	47	48.5
			Medium	35	39	40.5	43.5	43	46.5
			Low	33.5	37.5	39	41.5	41	44
			Super Low	18.5	18.5	18	19.5	19	19.5
Net Weight	Without Plenum		kg	11.5	14.5	16	17	20	28
	With Rear Plenum		kg	15	18	20	21	24.5	34
	With Bottom Plenum		kg	15	18.5	20.5	22	25	34.5
Fan	Type		Forward-Curve Multi-Blades Centrifugal Fan						
	Quantity		1	2	2	2	2	3	
Motor	Type		Brushless DC Motor						
	Protection Grade		IP42						
	Insulation Class		Class B						
	Quantity		1	1	1	1	1	2	
Coil	Type		Copper Tube / Hydrophilic Aluminum Fin						
	Working Pressure		1.8 MPa						
Connection	Water Inlet/Outlet		Rc 3/4" (Female)						
	Condensate Outlet		R 3/4" (Male)						
Options			Return Air Plenum, Filter, Valve, Thermostat, Electric Heater, Various Drain Pans						

Notes: 1. Airflow, cooling and heating capacities, etc. are performance data of bare unit (i.e. without return air plenum).

2. Normal Application:

- Cooling: inlet air dry/wet bulb temperature: 27/19.5°C; chilled water inlet/outlet temperature: 7/12°C.
- Heating: inlet air dry bulb temperature: 21°C; hot water inlet temperature: 60°C; same water flow rate as cooling.

3. Sound pressure data are bare unit (i.e. without return air plenum) tested in semi-anechoic room according to China standard GB/T 19232.

4 Rows Unit (2-Pipe)

Unit Size			DCHC02	DCHC03	DCHC04	DCHC05	DCHC06	DCHC08	DCHC10	DCHC12	DCHC14	
Airflow	m ³ /h	High	340	510	680	850	1020	1360	1700	2040	2380	
		Medium	280	410	550	690	830	1100	1360	1630	1900	
		Low	180	270	350	440	520	690	860	1020	1190	
Normal Application	Cooling Capacity	kW	High	2.54	3.66	4.73	5.55	7.01	9.21	11.16	13.07	14.93
	Heating Capacity	kW	High	4.00	5.69	7.20	8.82	10.73	14.17	17.61	20.16	23.43
	Water Flow Rate	l/s	High	0.12	0.18	0.23	0.27	0.33	0.44	0.53	0.62	0.71
	Water Pressure Drop	kPa	High	16	20	30	30	34	35	40	40	50
EarthWise Application	Cooling Capacity	kW	High	2.47	3.56	4.58	5.60	7.24	8.79	10.76	13.05	15.17
	Heating Capacity	kW	High	3.76	5.40	6.72	8.43	10.37	13.35	16.64	18.87	21.79
	Water Flow Rate	l/s	High	0.08	0.12	0.14	0.17	0.22	0.29	0.34	0.40	0.42
	Water Pressure Drop	kPa	High	16	30	28	24	40	40	40	40	50
Electric Heater Heating Capacity		kW	High	0.50	1.00	1.40	1.60	1.80	2.80	3.20	3.60	4.60
Power Input	12Pa	W	High	15	21	28	35	50	69	89	103	142
			Medium	11	16	20	28	37	48.5	66.5	87	127
			Low	6.5	8	9	12	14	22.5	26	32.5	45
			Super Low	4	4.5	4.5	5	5.5	9	9.5	10	10.5
	30Pa	W	High	20	30	37	47	63	84	106	122	167
			Medium	16.5	23.5	32	39.5	51	70.5	85.5	107.5	146.5
			Low	9	12.5	15.5	19	20	29.5	37	41.5	52
			Super Low	4	4.5	4.5	5	5.5	9	9.5	10	10.5
	50Pa	W	High	28	42	50	60	77	103	127	156	200
			Medium	22.5	33	45	52.5	60.5	85.5	113	130	172.5
			Low	12.5	17	23.5	27	29	42	56	59	70.5
			Super Low	4	4.5	4.5	5	5.5	9	9.5	10	10.5
Sound Pressure Level	12Pa	dBA	High	33	33.5	35	39	43	42	45	45.5	48.5
			Medium	27.5	30	31.5	35	38	37	41	42	45
			Low	24.5	25.5	27	29	31.5	31.5	34	35	37.5
			Super Low	17.5	17.5	18	17.5	18	18.5	19.5	19.5	19.5
	30Pa	dBA	High	37	37.5	39.5	42	44.5	44.5	47.5	48.5	50
			Medium	31.5	35.5	37.5	39	42.5	42	44.5	45.5	47.5
			Low	29.5	33	34.5	37	38	38	42	43	45
			Super Low	18	17.5	17.5	18	17.5	18	19.5	20	20
	50Pa	dBA	High	40	41	43	44	45.5	47	49.5	50	52
			Medium	34	37.5	39	42	41.5	45	47	47	49.5
			Low	32.5	36	37.5	40	39.5	42.5	45	44.5	46.5
			Super Low	17.5	17	16.5	18	17.5	18	19	19	19.5
Net Weight	Without Plenum		kg	12.5	15.5	17	18.5	21.5	29.5	33.5	36.5	39
	With Rear Plenum		kg	15.5	19	21	22.5	26	35.5	40	44.5	47.5
	With Bottom Plenum		kg	16	19.5	21.5	23	26.5	36	40.5	45	48
Fan	Type	Forward-Curve Multi-Blades Centrifugal Fan										
	Quantity	1	2	2	2	2	3	4	4	4	4	
Motor	Type	Brushless DC Motor										
	Protection Grade	IP42										
	Insulation Class	Class B										
	Quantity	1	1	1	1	1	2	2	2	2	2	
Coil	Type	Copper Tube / Hydrophilic Aluminum Fin										
	Working Pressure	1.8 MPa										
Connection	Water Inlet/Outlet	Rc 3/4" (Female)										
	Condensate Outlet	R 3/4" (Male)										
Options			Return Air Plenum, Filter, Valve, Thermostat, Electric Heater, Various Drain Pans									

Notes: 1. Airflow, cooling and heating capacities, etc. are performance data of bare unit (i.e. without return air plenum).

2. Normal Application:

- Cooling: inlet air dry/wet bulb temperature: 27/19.5°C; chilled water inlet/outlet temperature: 7/12°C.
- Heating: inlet air dry bulb temperature: 21°C; hot water inlet temperature: 60°C; same water flow rate as cooling.

3. EarthWise Application:

- Cooling: inlet air dry/wet bulb temperature: 27/19.5°C; chilled water inlet/outlet temperature: 5/13°C.
- Heating: inlet air dry bulb temperature: 21°C; hot water inlet temperature: 60°C; same water flow rate as cooling.

4. Sound pressure data are bare unit (i.e. without return air plenum) tested in semi-anechoic room according to China standard GB/T 19232.



Performance Data

HESP 3 Rows Unit (2-Pipe)

Unit Size				DCHC02	DCHC03	DCHC04	DCHC05	DCHC06	DCHC08	DCHC10	DCHC12	DCHC14
Normal Application	Airflow	m ³ /h	High	340	510	680	850	1020	1360	1700	2040	2380
	Cooling Capacity	kW	High	2.21	3.16	4.17	5.06	6.10	8.00	9.30	11.10	13.00
	Heating Capacity	kW	High	3.50	5.20	6.70	8.12	9.70	13.00	15.50	18.00	20.80
	Water Flow Rate	l/s	High	0.11	0.15	0.20	0.25	0.30	0.39	0.45	0.53	0.63
EarthWise Application	Water Pressure Drop	kPa	High	25	24	25	30	40	35	35	40	50
	Cooling Capacity	kW	High	2.21	3.14	3.99	5.02	6.10	7.98	9.85	11.31	13.29
	Heating Capacity	kW	High	3.37	4.84	6.32	7.56	9.16	12.27	14.92	17.15	19.95
	Water Flow Rate	l/s	High	0.07	0.10	0.12	0.16	0.20	0.24	0.29	0.34	0.40
High Capacity EarthWise Application	Water Pressure Drop	kPa	High	29	22	17	29	40	33	36	35	50
	Cooling Capacity	kW	Medium	-	2.06	2.70	3.39	4.20	5.41	6.53	7.49	8.87
	Heating Capacity	kW	Medium	-	3.61	4.73	5.93	7.35	9.47	11.43	13.11	15.52
	Water Flow Rate	l/s	Medium	-	0.06	0.08	0.11	0.12	0.16	0.19	0.22	0.27
Power Input	Water Pressure Drop	kPa	Medium	-	28	20	30	22	40	35	35	48
	112Pa	W		49	77	88	110	137	187	231	280	344
	100Pa		45	70	80	100	125	170	210	255	315	
	88Pa		41	63	73	90	113	153	189	230	286	
	75Pa		37	56	65	80	101	137	169	206	258	
	62Pa		32	49	58	70	89	120	148	181	229	
Super Low	4.5		5	5	5.5	6	9.5	10	10	10.5		
Sound Pressure Level	112Pa	dBA		45.0	49.0	49.0	51.5	51.0	52.5	53.5	53.0	54.0
	100Pa		43.5	48.0	47.5	50.0	50.0	51.0	52.5	52.0	53.0	
	88Pa		42.0	46.5	46.5	49.0	49.0	50.0	51.5	51.5	52.5	
	75Pa		40.5	45.0	45.0	47.5	48.0	49.0	50.5	50.5	51.5	
	62Pa		38.5	43.0	44.0	46.0	47.0	47.5	49.5	48.5	50.5	
	Super Low		19.0	19.0	19.0	19.0	19.0	19.0	19.0	19.0	19.0	
Net Weight	Without Plenum	kg		12.4	15.3	16.9	18.1	21.1	29.9	32.8	36.5	38.9
	With Rear Plenum	kg		15.4	18.8	20.9	22.6	26.1	35.9	39.8	44	46.9
	With Bottom Plenum	kg		15.9	19.3	21.4	23.1	26.6	36.4	40.3	44.5	47.9
Fan	Type	Forward-Curve Multi-Blades Centrifugal Fan										
	Quantity	1	2	2	2	3	4	4	4			
Motor	Type	Brushless DC Motor										
	Protection Grade	IP42										
	Insulation Class	Class B										
	Quantity	1	1	1	1	2	2	2	2			
Coil	Type	Copper Tube / Hydrophilic Aluminum Fin										
	Working Pressure	1.8 MPa										
Connection	Water Inlet/Outlet	Rc 3/4" (Female)										
	Condensate Outlet	R 3/4"(Male)										
Options			Return Air Plenum, Filter, Valve, Thermostat, Various Drain Pans									

- Notes:**
- Airflow, cooling and heating capacities, etc. are performance data of bare unit (i.e. without return air plenum).
 - Normal Application:
 - Cooling: inlet air dry/wet bulb temperature: 27/19.5°C; chilled water inlet/outlet temperature: 7/12°C.
 - Heating: inlet air dry bulb temperature: 21°C; hot water inlet temperature: 60°C; same water flow rate as cooling.
 - EarthWise Application:
 - Cooling: inlet air dry/wet bulb temperature: 27/19.5°C; chilled water inlet/outlet temperature: 5/13°C.
 - Heating: inlet air dry bulb temperature: 21°C; hot water inlet temperature: 60°C; same water flow rate as cooling.
 - High Capacity EarthWise Application:
 - Cooling: inlet air dry/wet bulb temperature: 26.7/19.4°C; chilled water inlet/outlet temperature: 7.2/15.6°C.
 - Heating: inlet air dry bulb temperature: 21°C; hot water inlet temperature: 60°C; same water flow rate as cooling.
 - Sound pressure data are bare unit (i.e. without return air plenum) tested in semi-anechoic room according to China standard GB/T 19232.

HESP 2 Rows Unit (2-Pipe)

Unit Size				DCHC02	DCHC03	DCHC04	DCHC05	DCHC06	DCHC08
Normal Application	Airflow	m ³ /h	High	350	520	690	870	1040	1380
	Cooling Capacity	kW	High	1.90	2.80	3.60	4.50	5.40	7.20
	Heating Capacity	kW	High	3.15	4.93	6.10	7.41	8.90	12.00
	Water Flow Rate	l/s	High	0.10	0.14	0.17	0.21	0.26	0.34
	Water Pressure Drop	kPa	High	15	30	25	30	34	36
Power Input	112Pa		W	49	77	88	110	137	187
	100Pa			45	70	80	100	125	170
	88Pa			41	63	73	90	113	153
	75Pa			37	56	65	80	101	137
	62Pa			32	49	58	70	89	120
	Super Low			4.5	5	5	5.5	6	9.5
Sound Pressure Level	112Pa		dBA	45.5	49.5	49.5	52.0	51.5	53.0
	100Pa			44.0	48.5	48.0	50.5	50.5	51.5
	88Pa			42.5	47.0	47.0	49.5	49.5	50.5
	75Pa			41.0	45.5	45.5	48.0	48.5	49.5
	62Pa			39.0	43.5	44.5	46.5	47.5	48.0
	Super Low			19.0	19.0	19.0	19.0	19.0	19.0
Net Weight	Without Plenum		kg	11.9	14.8	16.4	17.6	20.6	28.9
	With Rear Plenum		kg	15.4	18.3	20.4	21.6	25.1	34.9
	With Bottom Plenum		kg	15.4	18.8	20.9	22.6	25.6	35.4
Fan	Type			Forward-Curve Multi-Blades Centrifugal Fan					
	Quantity			1	2	2	2	2	3
Motor	Type			Brushless DC Motor					
	Protection Grade			IP42					
	Insulation Class			Class B					
	Quantity			1	1	1	1	1	2
Coil	Type			Copper Tube / Hydrophilic Aluminum Fin					
	Working Pressure			1.8 MPa					
Connection	Water Inlet/Outlet			Rc 3/4" (Female)					
	Condensate Outlet			R 3/4"(Male)					
Options				Return Air Plenum, Filter, Valve, Thermostat, Various Drain Pans					

Notes: 1. Airflow, cooling and heating capacities, etc. are performance data of bare unit (i.e. without return air plenum).

2. Normal Application:

- Cooling: inlet air dry/wet bulb temperature: 27/19.5°C; chilled water inlet/outlet temperature: 7/12°C.
- Heating: inlet air dry bulb temperature: 21°C; hot water inlet temperature: 60°C; same water flow rate as cooling.

3. Sound pressure data are bare unit (i.e. without return air plenum) tested in semi-anechoic room according to China standard GB/T 19232.



Performance Data

HESP 4 Rows Unit (2-Pipe)

Unit Size				DCHC02	DCHC03	DCHC04	DCHC05	DCHC06	DCHC08	DCHC10	DCHC12	DCHC14
Normal Application	Airflow	m ³ /h	High	340	510	680	850	1020	1360	1700	2040	2380
	Cooling Capacity	kW	High	2.54	3.66	4.73	5.55	7.01	9.21	11.16	13.07	14.93
	Heating Capacity	kW	High	4.00	5.69	7.20	8.82	10.73	14.17	17.61	20.16	23.43
	Water Flow Rate	l/s	High	0.12	0.18	0.23	0.27	0.33	0.44	0.53	0.62	0.71
EarthWise Application	Water Pressure Drop	kPa	High	16	20	30	30	34	35	40	40	50
	Cooling Capacity	kW	High	2.47	3.56	4.58	5.60	7.24	8.79	10.76	13.05	15.17
	Heating Capacity	kW	High	3.76	5.40	6.72	8.43	10.37	13.35	16.64	18.87	21.79
	Water Flow Rate	l/s	High	0.08	0.12	0.14	0.17	0.22	0.29	0.34	0.40	0.42
Power Input	112Pa	W		49	77	88	110	137	187	231	280	344
	100Pa		45	70	80	100	125	170	210	255	315	
	88Pa		41	63	73	90	113	153	189	230	286	
	75Pa		37	56	65	80	101	137	169	206	258	
	62Pa		32	49	58	70	89	120	148	181	229	
	Super Low		4.5	5	5	5.5	6	9.5	10	10	10.5	
Sound Pressure Level	112Pa	dBA		44.5	48.5	48.5	51.5	51.0	53.0	53.5	53.5	54.0
	100Pa		43.0	47.5	47.5	50.0	50.0	51.5	52.5	52.5	53.0	
	88Pa		41.5	46.5	46.0	49.0	49.0	50.5	51.5	52.0	53.0	
	75Pa		39.5	44.5	44.5	47.5	47.5	49.5	50.5	50.5	52.0	
	62Pa		37.5	42.5	43.5	45.5	47.0	48.0	49.0	49.0	51.0	
	Super Low		19.0	19.0	19.0	19.0	19.0	19.0	19.0	19.0	19.0	
Net Weight	Without Plenum	kg		12.9	15.8	17.4	19.1	22.1	30.4	34.3	37.5	39.9
	With Rear Plenum	kg		15.9	19.3	21.4	23.1	26.6	36.4	40.8	45.5	48.4
	With Bottom Plenum	kg		16.4	19.8	21.9	23.6	27.1	36.9	41.3	46	48.9
Fan	Type	Forward-Curve Multi-Blades Centrifugal Fan										
	Quantity	1	2	2	2	2	3	4	4	4	4	4
Motor	Type	Brushless DC Motor										
	Protection Grade	IP42										
	Insulation Class	Class B										
	Quantity	1	1	1	1	1	2	2	2	2	2	2
Coil	Type	Copper Tube / Hydrophilic Aluminum Fin										
	Working Pressure	1.8 MPa										
Connection	Water Inlet/Outlet	Rc 3/4" (Female)										
	Condensate Outlet	R 3/4" (Male)										
Options		Return Air Plenum, Filter, Valve, Thermostat, Various Drain Pans										

Notes: 1. Airflow, cooling and heating capacities, etc. are performance data of bare unit (i.e. without return air plenum).

2. Normal Application:

- Cooling: inlet air dry/wet bulb temperature: 27/19.5°C; chilled water inlet/outlet temperature: 7/12°C.
- Heating: inlet air dry bulb temperature: 21°C; hot water inlet temperature: 60°C; same water flow rate as cooling.

3. EarthWise Application:

- Cooling: inlet air dry/wet bulb temperature: 27/19.5°C; chilled water inlet/outlet temperature: 5/13°C.
- Heating: inlet air dry bulb temperature: 21°C; hot water inlet temperature: 60°C; same water flow rate as cooling.

4. Sound pressure data are bare unit (i.e. without return air plenum) tested in semi-anechoic room according to China standard GB/T 19232.



Airflow Curve

12Pa Motor

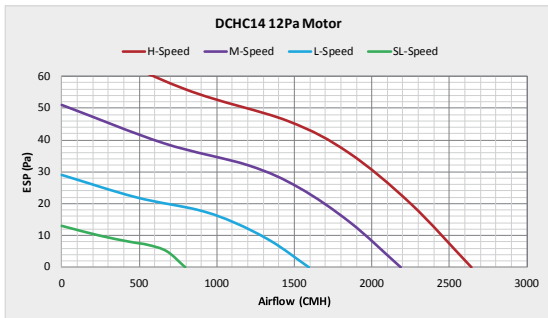
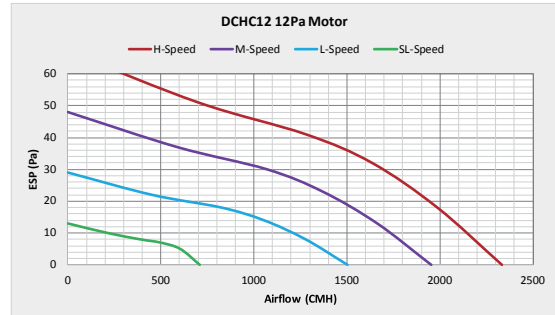
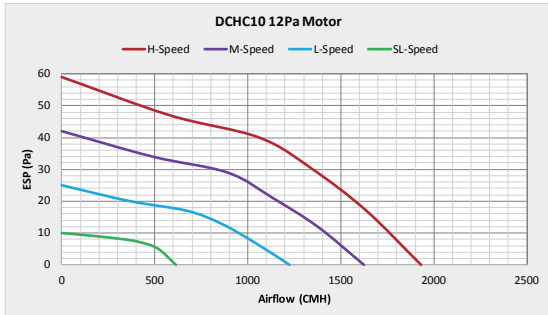
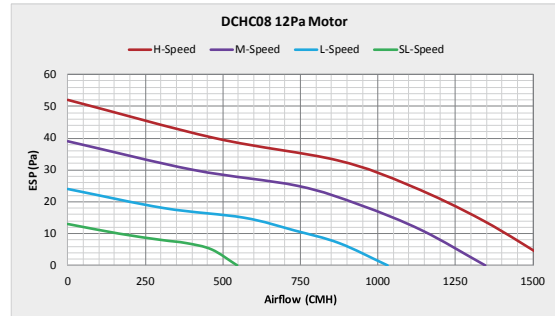
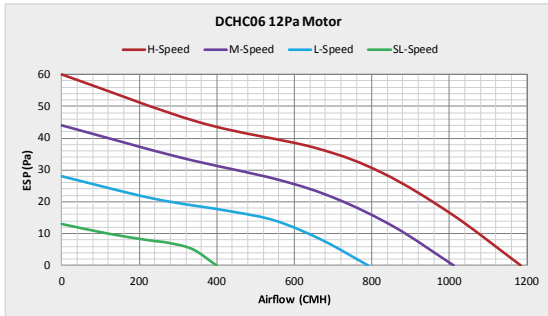
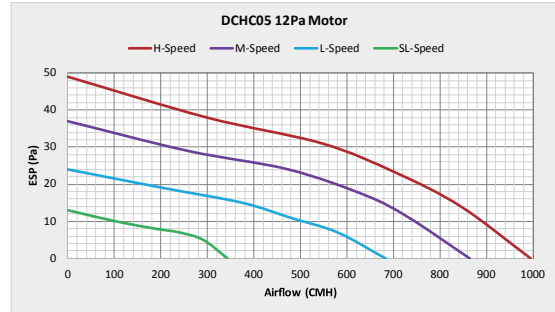
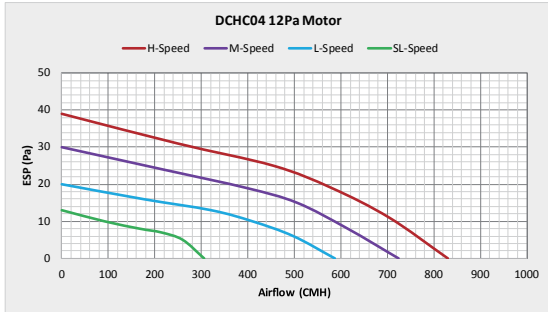
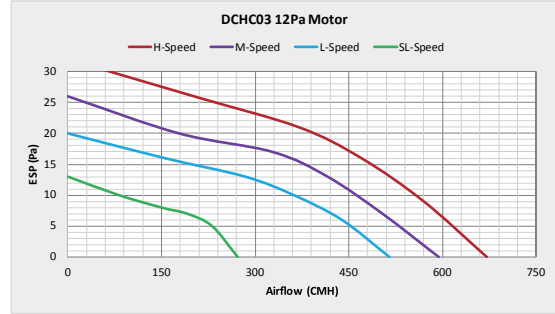
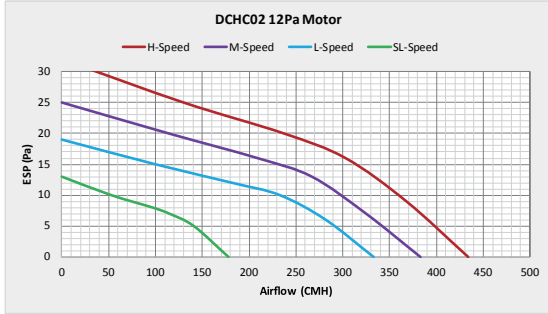

Notes:

1. The airflow curves are based on 3 row coil bare unit (i.e. without return air plenum).
2. Please use Trane TOPSS program or contact Trane sales to get selectable range for various configurations.

30Pa Motor

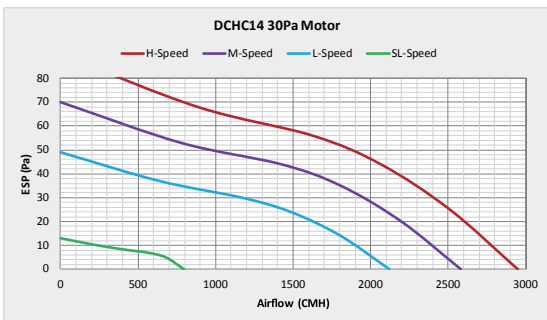
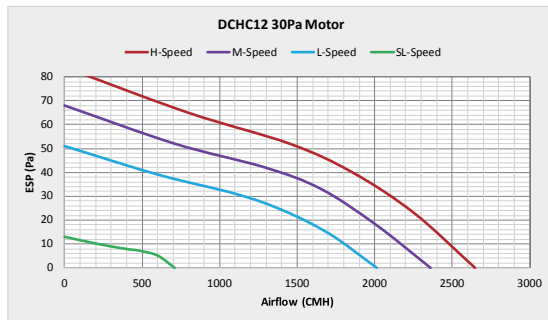
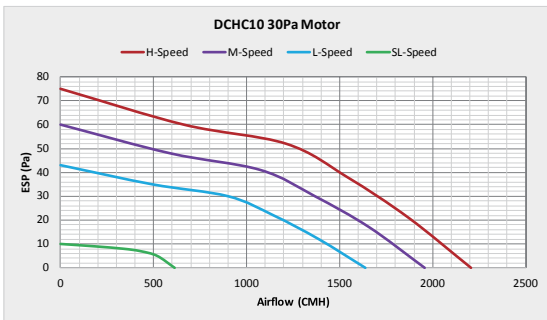
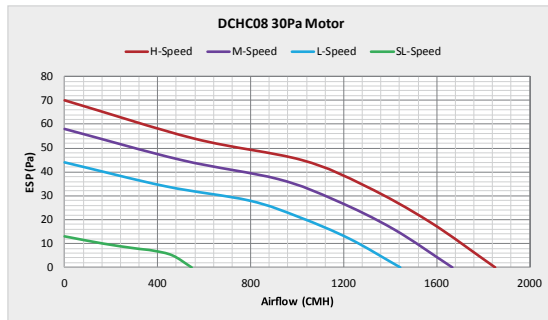
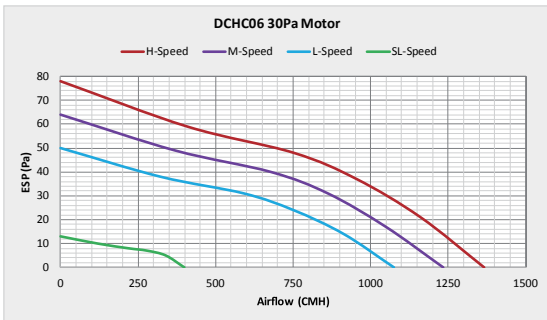
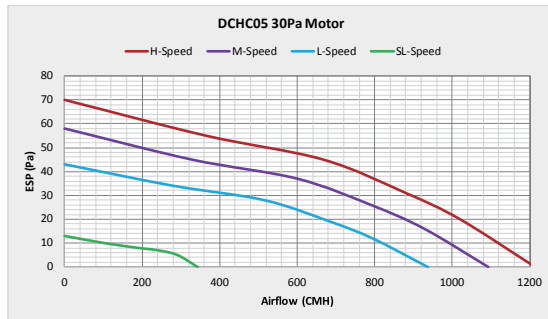
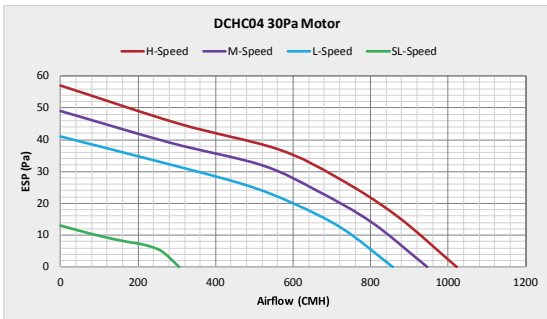
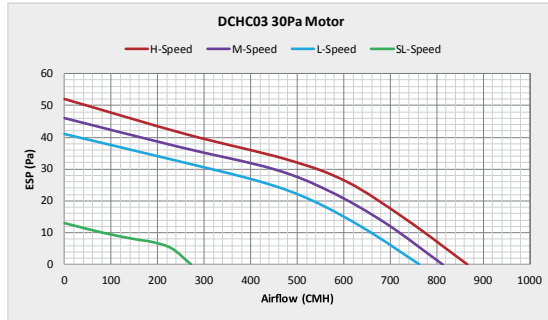
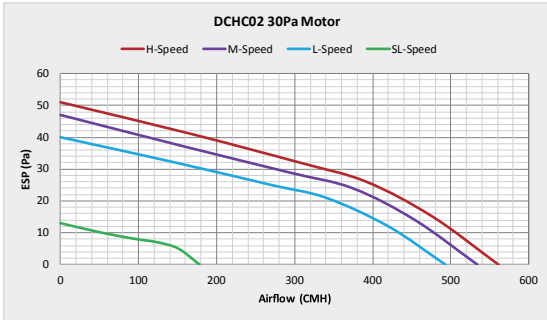

Notes:

1. The airflow curves are based on 3 row coil bare unit (i.e. without return air plenum).
2. Please use Trane TOPSS program or contact Trane sales to get selectable range for various configurations.

50Pa Motor

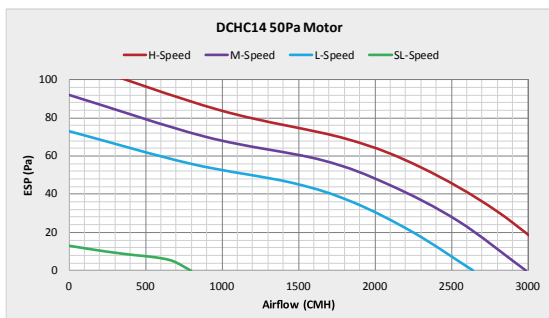
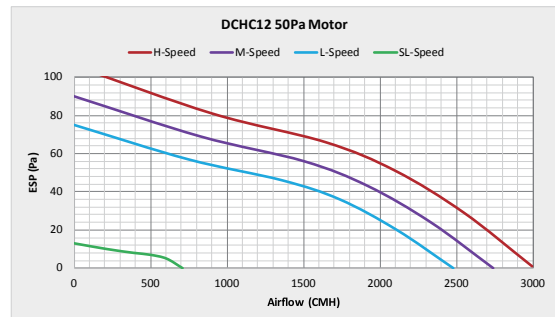
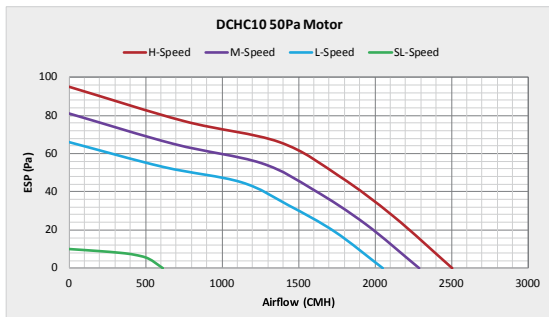
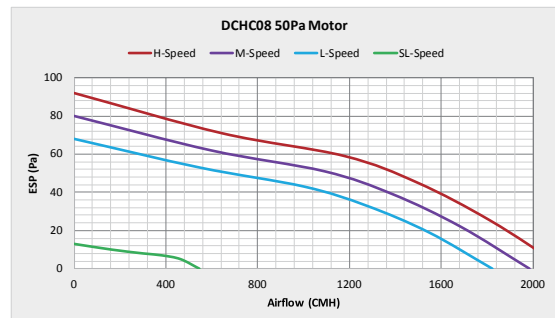
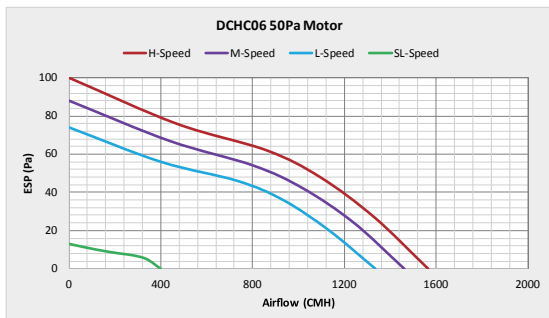
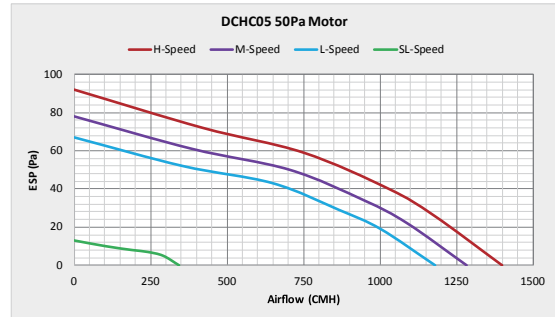
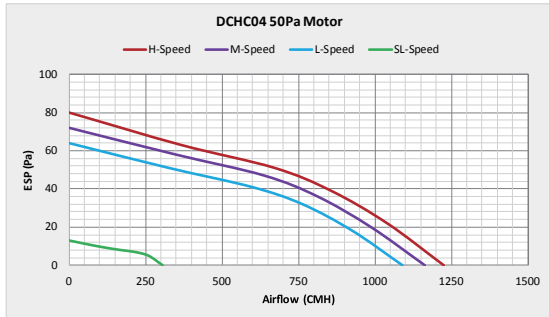
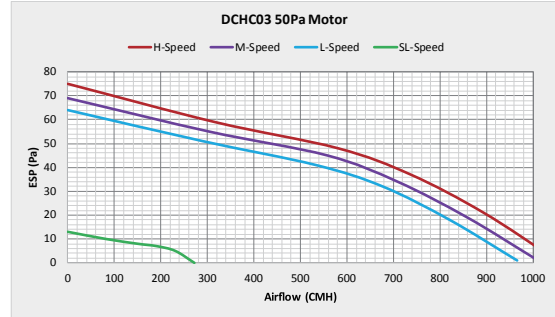
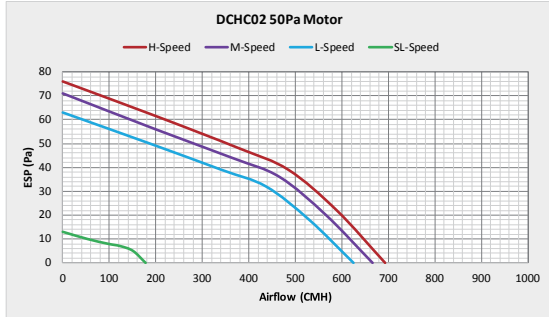

Notes:

1. The airflow curves are based on 3 row coil bare unit (i.e. without return air plenum).
2. Please use Trane TOPSS program or contact Trane sales to get selectable range for various configurations.

HESP 100Pa Motor

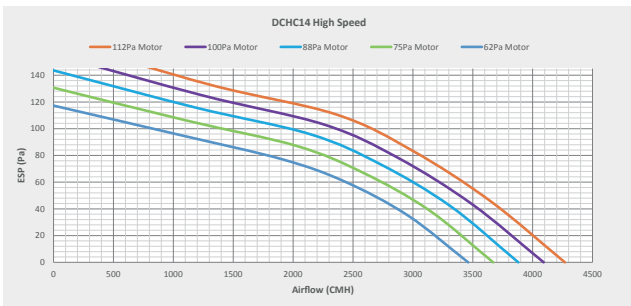
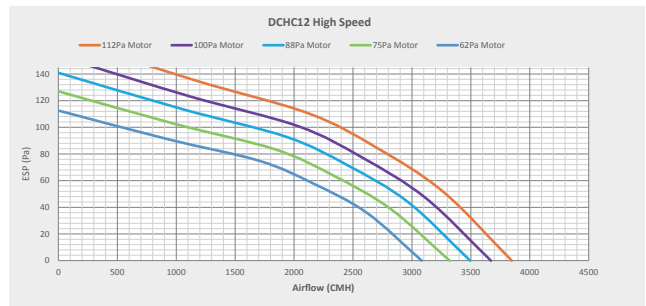
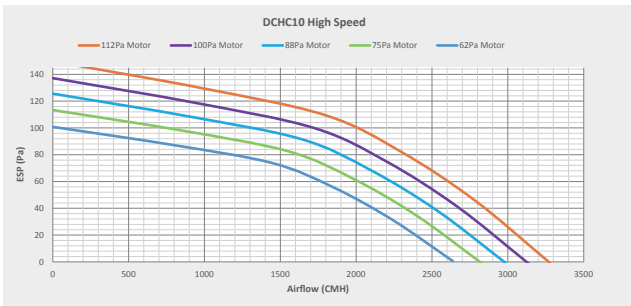
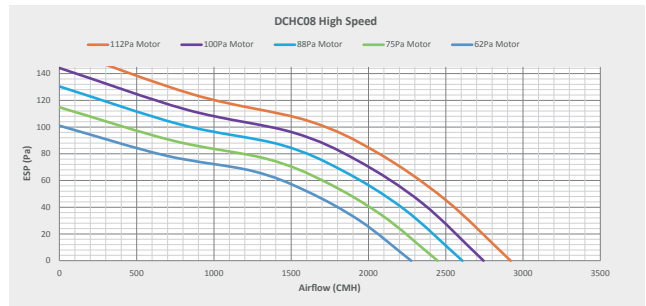
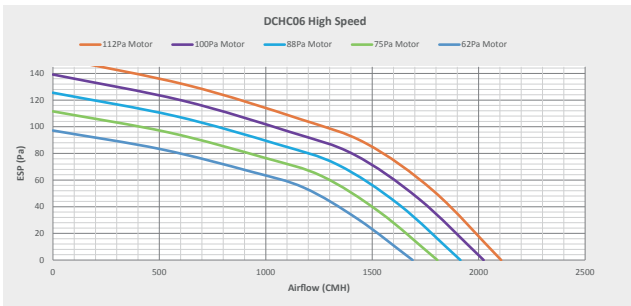
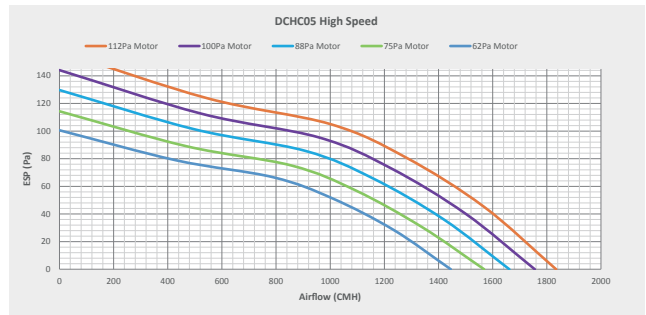
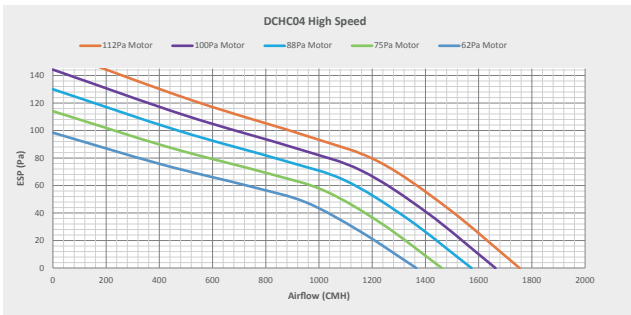
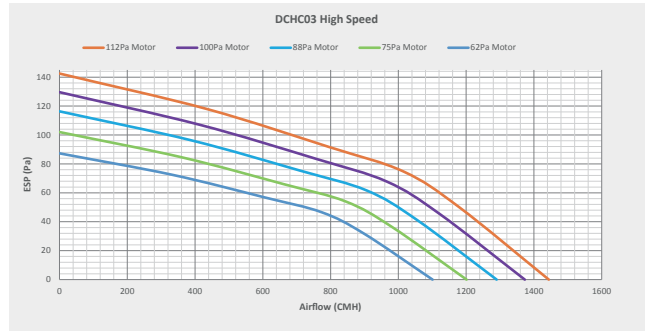
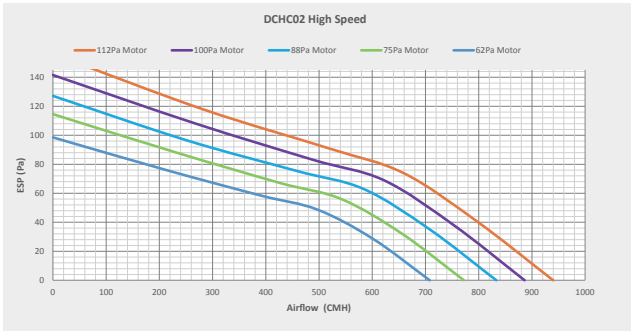

Notes:

1. The airflow curves are based on 3 row coil bare unit (i.e. without return air plenum).
2. Please use Trane TOPSS program or contact Trane sales to get selectable range for various configurations.



Dimensions

Unit without Return Air Plenum

2-Pipe Unit

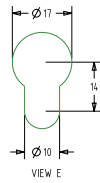
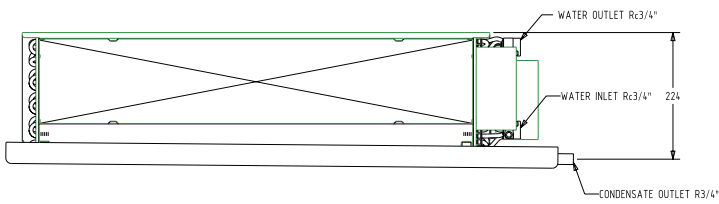
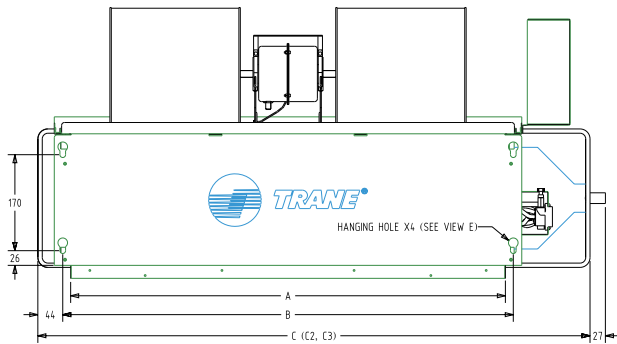

UNIT MODEL	DIMENSIONS mm					MOTOR NO.	FAN NO.
	A	B	C*	C2*	C3*		
DCHC02	440	468	648	84.8	958	1	1
DCHC03	590	618	798	99.8	1108	1	2
DCHC04	690	718	898	109.8	1208	1	2
DCHC05	770	798	978	117.8	1288	1	2
DCHC06	970	998	1183	138.3	1493	1	2
DCHC08	1210	1238	1423	162.3	1733	2	3
DCHC10	1330	1358	1543	174.3	1853	2	4
DCHC12	1570	1598	1783	198.3	2093	2	4
DCHC14	1750	1778	1963	216.3	2273	2	4

* C - UNIT WITH STANDARD LENGTH DRAIN PAN.
 C2 - UNIT WITH +200mm EXTENDED LENGTH DRAIN PAN.
 C3 - UNIT WITH +310mm EXTENDED LENGTH DRAIN PAN.

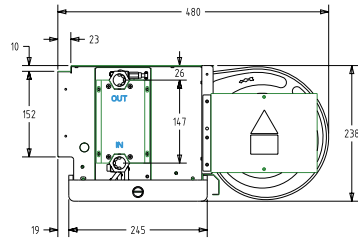

Unit with Return Air Plenum

Unit with Rear Return Air Plenum

WITH REAR RETURN PLENUM

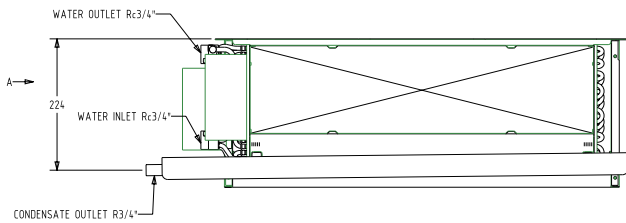
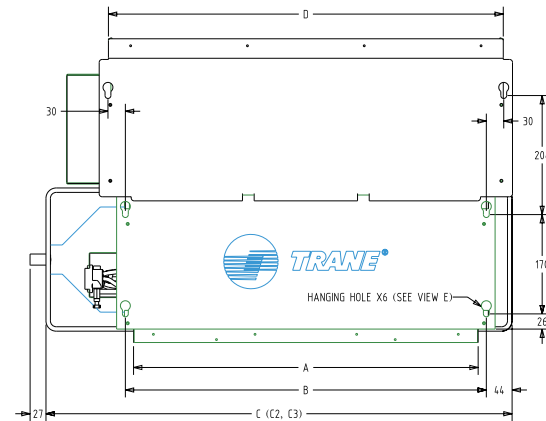

UNIT MODEL	DIMENSIONS mm					MOTOR NO.	FAN NO.
	A	B	C*	C2*	C3*		
DCHC02	440	468	648	848	958	526	1 1
DCHC03	590	618	798	998	1108	676	1 2
DCHC04	690	718	898	1098	1208	776	1 2
DCHC05	770	798	978	1178	1288	856	1 2
DCHC06	970	998	1183	1383	1493	1056	1 2
DCHC08	1210	1238	1423	1623	1733	1296	2 3
DCHC10	1330	1358	1543	1743	1853	1416	2 4
DCHC12	1570	1598	1783	1983	2093	1656	2 4
DCHC14	1750	1778	1963	2163	2273	1836	2 4

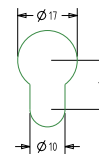

* C - UNIT WITH STANDARD LENGTH DRAIN PAN.
 C2 - UNIT WITH +200mm EXTENDED LENGTH DRAIN PAN.
 C3 - UNIT WITH +310mm EXTENDED LENGTH DRAIN PAN.

VIEW A

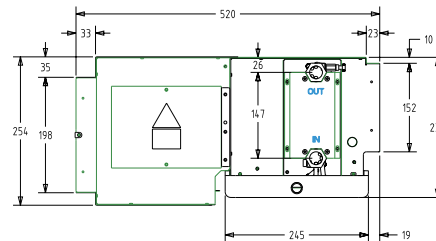

Unit with Bottom Return Air Plenum

WITH BOTTOM RETURN PLENUM

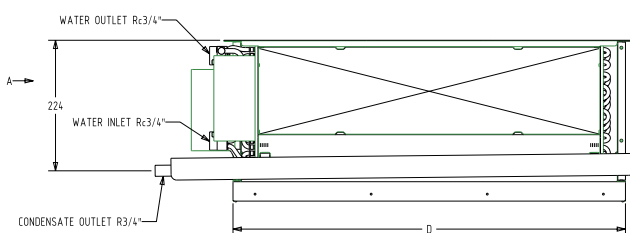
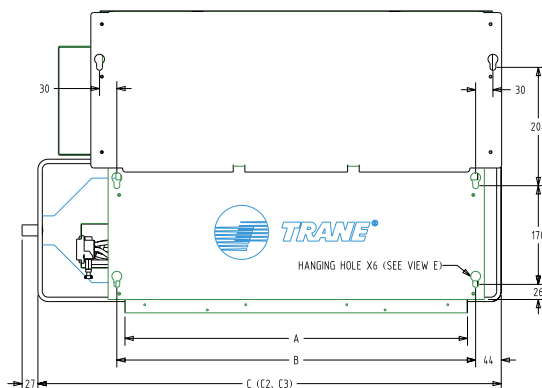

UNIT MODEL	DIMENSIONS mm					MOTOR NO.	FAN NO.
	A	B	C*	C2*	C3*		
DCHC02	440	468	648	848	958	526	1 1
DCHC03	590	618	798	998	1108	676	1 2
DCHC04	690	718	898	1098	1208	776	1 2
DCHC05	770	798	978	1178	1288	856	1 2
DCHC06	970	998	1183	1383	1493	1056	1 2
DCHC08	1210	1238	1423	1623	1733	1296	2 3
DCHC10	1330	1358	1543	1743	1853	1416	2 4
DCHC12	1570	1598	1783	1983	2093	1656	2 4
DCHC14	1750	1778	1963	2163	2273	1836	2 4

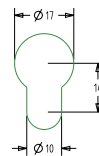

* C - UNIT WITH STANDARD LENGTH DRAIN PAN.
 C2 - UNIT WITH +200mm EXTENDED LENGTH DRAIN PAN.
 C3 - UNIT WITH +310mm EXTENDED LENGTH DRAIN PAN.

VIEW A

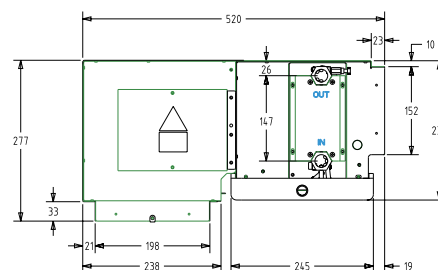

Wiring Diagrams

Unit Wiring Diagram (with DCBL Thermostat)

Single-Motor Unit

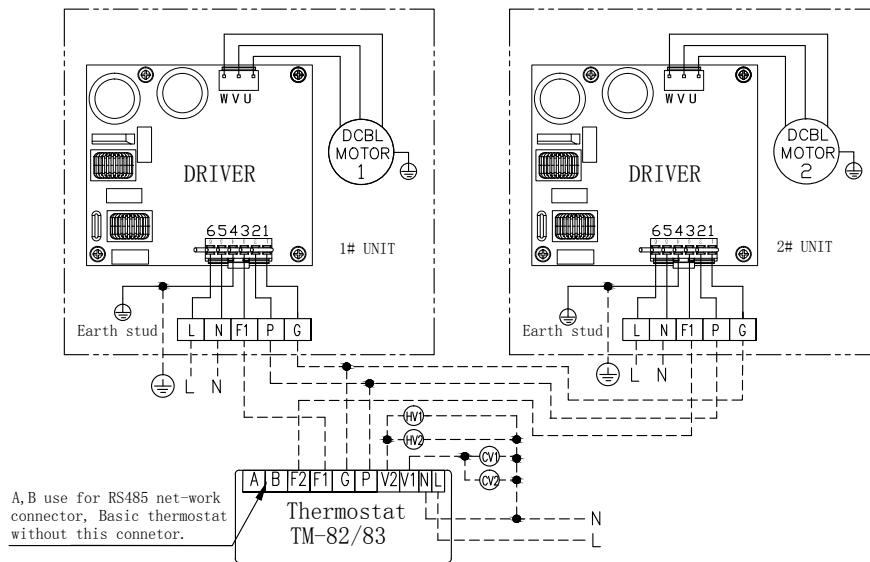

DCHC02 ~ 06

Power input: 220V/50 ~ 60Hz/1Phase
 Note: For single motor unit, the TM82/83 can control one unit or two units with the same model number.

Remark

- L: Live line
- N: Neutral line
- CV: Cooling valve(option)
- HV: Heating valve(option)
- Factory wiring
- Field wiring

Double-Motor Unit

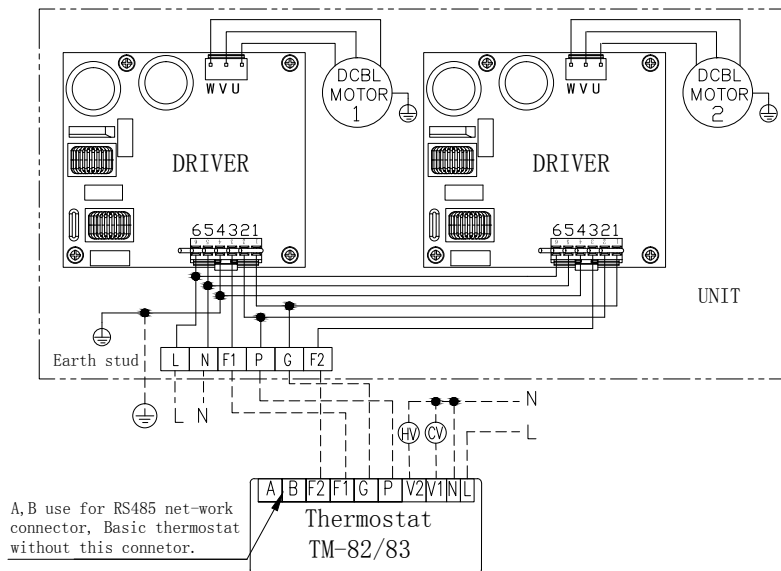

DCHC08 ~ 14

Power input: 220V/50 ~ 60Hz/1Phase

Remark

- L: Live line
- N: Neutral line
- CV: Cooling valve(option)
- HV: Heating valve(option)
- Factory wiring
- Field wiring

- Caution**
1. Thermostat control line and power source cable must be independently cabled.
 2. The thermostat control line must adopt UL2464/22AWG or above.
 3. The control line between thermostat and driver can not exceed 16m.



Power Source must be cut off before maintenance to avoid personal injuries caused by electrical shock.

Unit Wiring Diagram (with 3-Speed Module)

Single-Motor Unit

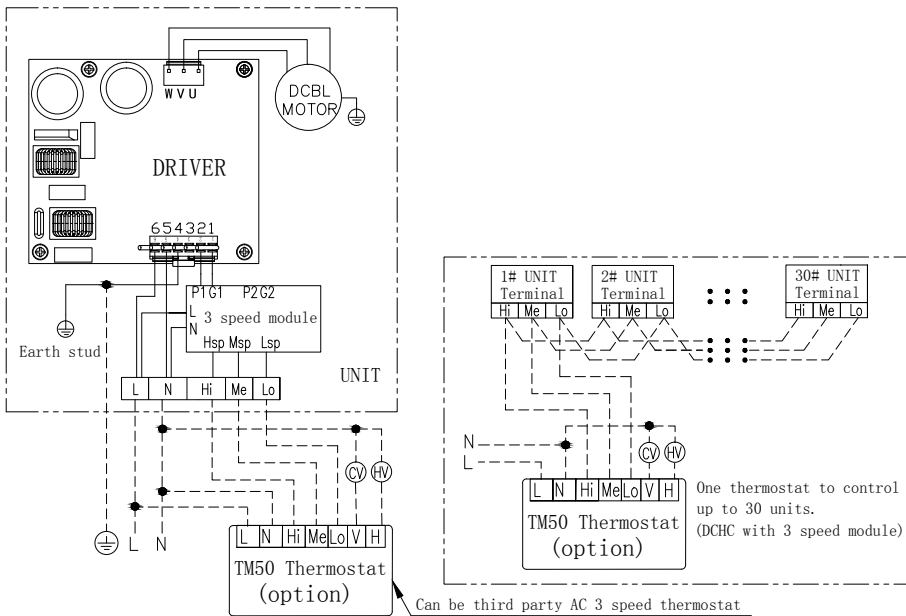

DCHC02 ~ 06

Power input: 220V/50 ~ 60Hz/1Phase

Remark

- L: Live line
- N: Neutral line
- CV: Cooling valve(option)
- HV: Heating valve(option)
- Factory wiring
- Field wiring

Double-Motor Unit

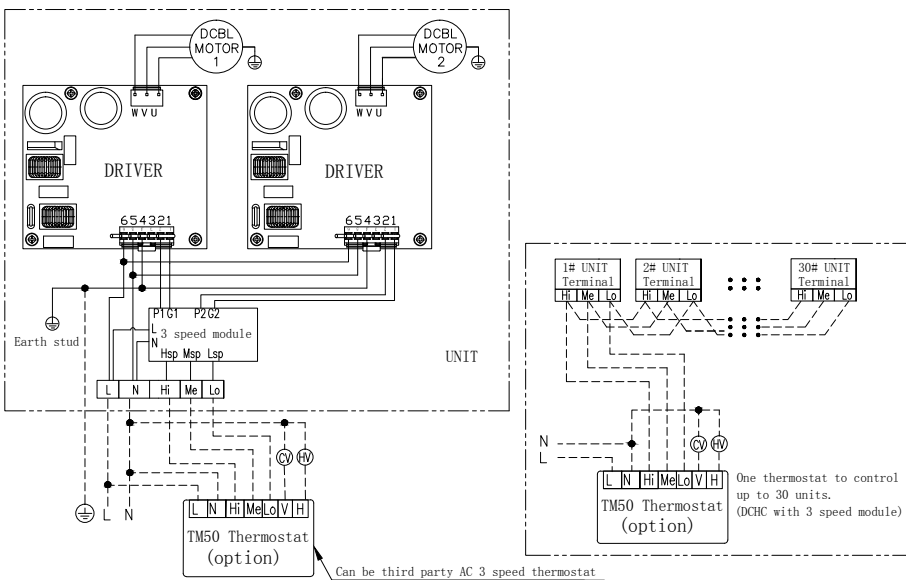

DCHC08 ~ 14

Power input: 220V/50 ~ 60Hz/1Phase

Remark

- L: Live line
- N: Neutral line
- CV: Cooling valve(option)
- HV: Heating valve(option)
- Factory wiring
- Field wiring



Power Source must be cut off before maintenance to avoid personal injuries caused by electrical shock.

Unit Wiring Diagram (with V-speed modular)

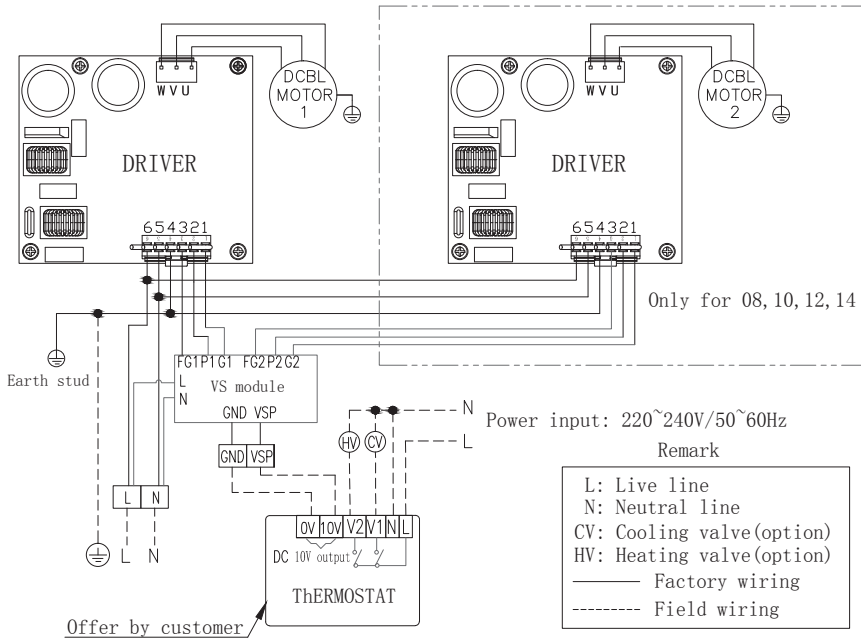

Power Source must be cut off before maintenance to avoid personal injuries caused by electrical shock.

Trane - by Trane Technologies (NYSE: TT), a global climate innovator - creates comfortable, energy efficient indoor environments for commercial and residential applications. For more information, please visit trane.com or tranetechnologies.com.

Trane has a policy of continuous product and product data improvement and reserves the right to change design and specifications without notice. We are committed to using environmentally conscious print practices.