



Product Catalog

# Series R™ Helical Rotary Water-Cooled Liquid Chillers

Model RTWD

65-250 Tons - 50Hz





## Introduction

To meet a wide range of applications in the 65–250 ton water-cooled market, Trane is proud to introduce the model RTWD helical-rotary liquid chiller. The introduction of this next-generation chiller is an exciting step forward in application versatility, ease of installation, control precision, reliability, energy-efficiency, and operational cost-effectiveness. The new RTWD chiller is designed to deliver proven Series R performance, plus all the benefits of an advanced heat transfer design with two low-speed, direct-drive compressors.

### **Important Design Advances and New Features**

- Higher full-load energy efficiency that meets ASHRAE 90.1 and reduces both operating and life-cycle costs.
- Variable evaporator flow compensation for improved control stability with energy saving variable flow applications.
- Single chiller time of day scheduling communication option for easier control of small jobs.
- Dual independent refrigerant circuits.
- HFC-134a optimized design.

The industrial-grade design of the Series R helical-rotary chiller is ideal for both industrial and commercial markets, in applications such as office buildings, hospitals, schools, retail buildings, and industrial facilities. The reliable compressors, wide operating temperature range, advanced controls, electronic expansion valve, short anti-recycle timers, and industry-leading efficiencies mean that this latest Trane Series R chiller is the perfect choice for tight temperature control in almost any application temperatures, and under widely varying loads.

# Table of Contents

Introduction .....	2
Features and Benefits .....	4
Application Considerations .....	7
Model Number Descriptions .....	10
General Data .....	12
Performance Data .....	16
Controls .....	33
Electrical Data .....	36
Electrical Connections .....	42
Dimensions .....	50
Mechanical Specifications .....	57
Options .....	60



# Features and Benefits

## Reliability

- The Trane helical rotary compressor is a proven design resulting from years of research and thousands of test hours, including extensive testing under extraordinarily severe operating conditions.
- Trane is the world's largest manufacturer of large helical rotary compressors, with more than 240,000 compressors installed worldwide.
- Direct drive, low-speed compressors—a simple design with only four moving parts—provides maximum efficiency, high reliability, and low maintenance requirements.
- Suction gas-cooled motor stays at a uniformly low temperature for long motor life.
- Electronic expansion valve, with fewer moving parts than alternative valve designs, provides highly reliable operation.

## High Performance

- Advanced design enables chilled water temperature control to  $\pm 0.5^{\circ}\text{F}$  ( $0.28^{\circ}\text{C}$ ) for flow changes up to 10 percent per minute, plus handling of flow changes up to 30 percent per minute for variable flow applications.
- Two minute stop-to-start and five minute start-to-start anti-recycle timer allows tight chilled water temperature control in constant or transient low-load applications.
- High compressor lift capabilities for use with heat recovery and waterside heat pump applications allows highly efficient system design with minimal operational concerns.
- Tight water temperature control extends to operation of multiple chillers in parallel or series configurations, offering further system design flexibility for maximum efficiency.
- Optional LonTalk/Tracer Summit communications interface provides excellent, trouble-free inter operability.

## Life Cycle Cost-Effectiveness

- Precise compressor rotor tip clearance ensures optimal efficiency.
- Condenser and evaporator tubes use the latest heat transfer technology for increased efficiency.
- Electronic expansion valve enables exceptionally tight temperature control and extremely low superheat, resulting in more efficient full-load and part-load operation than previously available.
- Chilled water reset based on return water temperature is standard.
- Electrical current-limiting is available as an option.

## Application Versatility

- **Industrial/low temperature process cooling** – Excellent operating temperature range and precise control capabilities enable tight control with single chiller or series configuration.
- **Ice/thermal storage** – Specifiers and operators benefit from dual setpoint control and industry-leading temperature, efficiency, and control capabilities, plus outstanding support through partnership with Calmac, a strong Trane partner providing proven installation examples, templates, and references that minimize design time and energy costs.
- **Heat recovery** – Maximum condenser temperature exceeds those of previous technologies, providing hot water and tight control that minimizes operating costs for the chilled water plant and boiler/hot water heater, while also providing consistent dehumidification.
- **Water to water heat pump** – For multi-chiller systems where there is a base or year-round heating load the RTWD can be used as a water side heat pump by utilizing ground or surface water as a heat source. Leaving condenser temperature control option allows for the chiller to be used and controlled primarily for the heat produced in the condenser.
- **Dry Cooler** – Allows for use with a closed condenser loop system that minimizes the potential for cross-contamination of the condenser loop.
- **Variable primary flow** – Variable evaporator flow compensation allows multi-chiller systems to vary the flow of water throughout the entire system (from the evaporator through the cooling coils). This feature also provides additional system efficiency as the number of pumps and the flow rate in the system are reduced. Standard 2 pass or optional 3 pass evaporator allows for a wider range of flow capabilities.
- **Series chiller configuration** – For two-chiller systems all the system water passes through the evaporators and/or condensers of both chillers to take advantage of system efficiency gains due to thermodynamic staging as well as downsizing the upstream chiller.
- **EarthWise system** – Low flow and high temperature differential installations allow for reduced pump and cooling-tower energy by decreasing the amount of water flow pumped through the system. This results in downsizing of all HVAC and ancillary equipment which provides installation and operational savings.



## Features and Benefits

---

### Simple, Economical Installation

- All units fit through standard double-width doors. Units are designed with bolt-together construction for disassembly to fit through smaller openings.
- Small footprint saves valuable equipment room space and alleviates access concerns for most retrofit jobs.
- Lightweight design simplifies rigging requirements, further reducing installation time requirements and costs.
- Full factory refrigerant and oil charges reduce required field labor, materials, and installation cost. An optional nitrogen charge can reduce the time and labor for projects expecting disassembly.
- Optional integrated forklift channels on the unit base allow for easy movement of the chiller at the job site.
- Single or dual point power connection options simplify overall installation.
- Unit-mounted starter eliminates additional job site installation considerations and labor requirements.
- Trane CH530 controls easily interface with Tracer Summit™ or LonTalk™ building automation systems through single twisted-pair wire.
- Trane has conducted extensive factory testing during manufacturing, and also offers options for in-person and/or documented system performance verification.

### Precision Control

- Microprocessor-based Trane CH530 controls monitor and maintain optimal operation of the chiller and its associated sensors, actuators, relays, and switches, all of which are factory-assembled and extensively tested.
- Easy interface with computers hosting LonTalk/Tracer Summit building automation/energy management systems allows the operator to efficiently optimize comfort system performance and minimize operating costs.
- Proportional Integral Derivative (PID) control strategy ensures stable, efficient chilled water temperature, maintaining  $\pm 1^{\circ}\text{F}$  ( $0.56^{\circ}\text{C}$ ) by reacting to instantaneous load changes.
- Adaptive Control™ attempts to maintain chiller operation under adverse conditions, when many other chillers might simply shut down. This is accomplished by unloading the compressor due to high condensing pressure, low suction pressure and/or overcurrent.
- Easy-to-use operator interface displays all operating and safety messages, with complete diagnostics information, on a easily readable panel with a scrolling touch-screen display.
- New variable evaporator flow compensation maintains improved control stability of the leaving water temperature.

# Application Considerations

## Condenser Water Temperatures

With the model RTWD chiller, condenser head pressure control is necessary only if the unit starts with entering condenser water temperatures below 55°F (12.8°C), or between 45°F (7.2°C) and 55°F (12.8°C), when a temperature increase of 1°F (0.56°C) per minute to 55°F (12.8°C) is not possible.

When the application requires startup temperatures below the prescribed minimums, a variety of system implementation options are available including the use of a 2- or 3-way valve or tower bypass to maintain the required system refrigerant differential pressure.

- To control a 2-way or 3-way valve, select the Condenser Regulating Valve Control option for the Trane CH530 controls. This option enables the CH530 controls to send a signal for opening and closing the valve as necessary to maintain chiller differential refrigerant pressure. The 2-way valves are available as a ship-with option.
- Tower bypass may also be a valid control method if the chiller temperature requirements can be maintained and the loop is small.

The minimum acceptable refrigerant pressure differential between condenser and evaporator is 25 psid (1.7 bars) at all load conditions in order to ensure adequate oil circulation. Condenser leaving water temperature must be 17°F (9.5°C) higher than evaporator leaving water temperature within 2 minutes of startup. A 25°F (13.9°C) temperature difference must be maintained thereafter [this differential requirement is lessened by 0.25°F (0.14°C) for every 1°F (0.56°C) that the condenser leaving water temperature is above 55°F (12.8°C)].

Trane Series R chillers start and operate successfully and reliably over a range of load conditions with controlled condenser pressure. Reducing the condenser water temperature is an effective method of lowering chiller power input required, but the ideal temperature for optimizing total system power consumption will depend on the overall system dynamics. From a system perspective, some improvements in chiller efficiency may be offset by the increased tower fan and pumping costs required to achieve the lower tower temperatures. Contact your local Trane systems solution provider for more information on optimizing system performance.

## Variable Evaporator Flow and Short Evaporator Water Loops

Variable evaporator flow is an energy-saving design strategy which has quickly gained acceptance as advances in chiller and controls technology have made it possible. With its superior unloading compressor design and advanced Trane CH530 controls, the RTWD has excellent capability to maintain leaving water temperature control within  $\pm 0.5^\circ\text{F}$  (0.28°C), even for systems with variable evaporator flow.

Some basic rules should be followed whenever using these system design and operational savings methods with the RTWD. The proper location of the chilled water temperature control sensor is in the supply (outlet) water. This location allows the building to act as a buffer, and it assures a slowly changing return water temperature. If there is insufficient water volume in the system to provide an adequate buffer, temperature control can be lost, resulting in erratic system operation and excessive compressor cycling. To ensure consistent operation and tight temperature control, the chilled water loop should be at least two minutes. If this recommendation cannot be followed, and tight leaving water temperature control is necessary, a storage tank or larger header pipe should be installed to increase the volume of water in the system.

## Application Considerations

---

For variable primary flow applications, the rate of chilled water flow change should not exceed 10 percent of design per minute to maintain  $\pm 0.5^{\circ}\text{F}$  ( $0.28^{\circ}\text{C}$ ) leaving evaporator temperature control. For applications in which system energy savings is most important and tight temperature control is classified as  $\pm 2^{\circ}\text{F}$  ( $1.1^{\circ}\text{C}$ ), up to 30 percent change in flow per minute are possible. Flow rates should be maintained between the minimum and maximum allowed for any particular chiller configuration.

For applications designed to operate with changes in the water flow rate, the new evaporator water-flow compensation improves the ability of the chiller to respond to increasing or decreasing water flow. This new standard control feature works by varying the leaving evaporator temperature control gains in response to changes in evaporator water flow. By measuring the refrigerant flow in each circuit and using this value to calculate the resulting waterside temperature drop, the CH530 can estimate the water flow rate through the evaporator.

## Series Chiller Arrangements

Another energy-saving strategy is to design the system around chillers arranged in series, on the evaporator, condenser, or both. It is possible to operate a pair of chillers more efficiently in a series chiller arrangement than in a parallel arrangement. It is also possible to achieve higher entering-to-leaving chiller differentials, which may, in turn, provide the opportunity for lower chilled water design temperature, lower design flow, and resulting installation and operational cost savings (including downsizing a chiller).

The Trane screw compressor also has excellent "lift" capabilities which afford an opportunity for savings on the evaporator and condenser water loops. Like series arrangements on the evaporator, series arrangements on the condenser may enable savings. This approach may allow reductions in pump and tower installation and operating costs.

Maximizing system efficiency requires that the designer balance performance considerations for all system components; the best approach may or may not involve multiple chillers, or series arrangement of the evaporators and/or condensers. This ideal balance of design integrity with installation and operating cost considerations should be researched by consulting a Trane systems solutions provider and applying the Trace™ building energy and economic analysis program.

## Heat Recovery

At a time when energy costs are high and continue to rise, reducing energy usage has become increasingly important. By using a RTWD chiller with heat recovery, utilization of energy can be improved by using heat from the condenser that would otherwise be wasted.

The use of heat recovery should be considered in any building with simultaneous heating and cooling requirements or in facilities where heat can be stored and used at a later time. Buildings with high year-round internal cooling loads are excellent opportunities for heat recovery. Heat recovery can be accomplished with the RTWD by recovering heat from the water leaving the standard condenser and using it in conjunction with a third party heat exchanger.



## Water-to-Water Heat Pump

The RTWD can be used as a water side heat pump by using ground or surface water as a heat source. Leaving condenser water control option provides the ability to control the heating setpoint. Local regulation concerning limitation on minimum/maximum rejected water temperature needs to be checked before using this method.

## Dry Cooler

The RTWD can be used with dry coolers. Generally this application is selected to minimize the spread of airborne contaminants associated with open tower systems. In addition, other drawbacks of cooling towers are avoided: water consumption, production of vapor, need of water treatment, etc. Another benefit of dry coolers is the ability to operate in low ambient conditions. With the use of a third party heat exchanger this design can also be used to provide free cooling to the chilled water loop during cold weather.

## Water Treatment

The use of untreated or improperly treated water in chillers may result in scaling, erosion, corrosion, and algae or slime buildup. It is recommended that the services of a qualified water treatment specialist be engaged to determine what treatment, if any, is advisable.

## Water Pumps

Where noise limitation and vibration-free operation are important, Trane strongly encourages the use of 1450-rpm (50 Hz) pumps. Specifying or using 3000-rpm (50 Hz) condenser water and chilled water pumps must be avoided, because such pumps may operate with objectionable levels of noise and vibration. In addition, a low frequency beat may occur due to the slight difference in operating rpm between 3000-rpm (50 Hz) water pumps and Series R chiller motors.

**Note:** *The chilled water pump must not be used to stop the chiller.*

## Acoustic Considerations

- For chiller sound ratings, installation tips, and considerations on chiller location, pipe isolation, etc., refer to *the Water-Cooled Series R Chillers Sound Ratings and Installation Guide*.



# Model Number Descriptions

## Digits 01, 02, 03, 04 – Chiller Model

RTWD = Water Cooled Chiller Series R™

## Digit 05, 06, 07 – Unit Nominal Tonnage

060 = 60 Nominal Tons  
070 = 70 Nominal Tons  
080 = 80 Nominal Tons  
090 = 90 Nominal Tons  
100 = 100 Nominal Tons  
110 = 110 Nominal Tons  
120 = 120 Nominal Tons  
130 = 130 Nominal Tons  
140 = 140 Nominal Tons  
150 = 150 Nominal Tons  
160 = 160 Nominal Tons  
180 = 180 Nominal Tons  
200 = 200 Nominal Tons  
220 = 220 Nominal Tons  
250 = 250 Nominal Tons

## Digit 08 – Unit Voltage

C = 380/50/3  
E = 400/50/3

## Digit 09 – Manufacturing Plant

1 = Epinal, France  
2 = Pueblo, USA  
3 = Taicang, China

## Digit 10, 11 – Design Sequence

\*\* = First Design, etc. increment when parts are affected for service purposes

## Digits 12 – Unit Type

1 = Standard Efficiency/Performance  
2 = High Efficiency/Performance  
3 = Premium Efficiency/Performance

## Digit 13 – Agency Listing

0 = No Agency Listing  
C = Manufactured to GB Standards

## Digit 14 – Pressure Vessel Code

1 = ASME Pressure Vessel Code  
4 = Chinese Code-China Built Vessel  
S = Special

## Digit 15 – Unit Application

A = Std Condenser <=95°F/35°C Entering Water Temperature  
B = High Temperature Condenser >95°F/35°C Entering Water Temperature  
C = Water-to-Water Heat Pump (<=140°F/60°C Hot Water Temp)  
F = Water-to-Water Heat Pump (<=122°F/50°C Hot Water Temp)

## Digit 16 – Pressure Relief Valve

1 = Single Relief Valve  
2 = Dual Relief Valve with 3-Way Isolation Valve

## Digit 17 – Water Connection Type

B = Flanged Connection - Metric

## Digit 18 – Evaporator Tubes

A = Internal and External Enhanced Evap Tube

## Digit 19 – Number of Evap Passes

1 = 2 Pass Evaporator  
2 = 3 Pass Evaporator

## Digit 20 – Evaporator Water Side Pressure

A = 150 psi/10.5 bar Evaporator Water Pressure  
S = 300 psi/20.6 bar Evap Water Pressure

## Digit 21 – Evaporator Application

1 = Standard Cooling  
2 = Low Temperature  
3 = Ice Making

## Digit 22 – Condenser Tubes

A = Enhanced Fin - Copper  
B = Internally Enhanced 90/10 CuNi Fin

## Digit 23 – Condenser Water Side Pressure

1 = 150 psi/10.5 Bar Condenser Water Pressure  
S = 300 psi/20.6 bar Cond Water Pressure

## Digit 24 – Compressor Starter Type

Y = Wye-Delta Closed Transition Starter  
X = Across-the-Line Starter

## Digit 25 – Incoming Power Line Connection

1 = Single Point Power Connection  
2 = Dual Point Power Connection

## Digit 26 – Power Line Connection Type

A = Terminal Block Connection for Incoming Lines  
B = Mechanical Disconnect Switch  
D = Circuit Breaker

## Digit 27 – Under/Over Voltage Protection

0 = No Under/Over Voltage Protection  
1 = Under/Over Voltage Protection

## Digit 28 – Unit Operator Interface

A = Dyna-View/English  
B = Dyna-View/Spanish  
C = Dyna-View/Spanish-Mexico  
D = Dyna-View/French  
E = Dyna-View/German  
F = Dyna-View/Dutch  
G = Dyna-View/Italian  
H = Dyna-View/Japanese  
J = Dyna-View/Portuguese-Portugal  
K = Dyna-View/Portuguese-Brazil  
L = Dyna-View/Korean  
M = Dyna-View/Thai  
N = Dyna-View/Simplified Chinese  
P = Dyna-View/Traditional Chinese  
R = Dyna-View/Russian  
T = Dyna-View/Polish  
U = Dyna-View/Czech  
V = Dyna-View/Hungarian  
W = Dyna-View/Greek  
X = Dyna-View/Romanian  
Y = Dyna-View/Swedish

## Model Number Descriptions

### Digit 29 – Remote Interface (Digital Comm)

0 = No Remote Digital Communication  
1 = LonTalk/Tracer Summit Interface  
2 = Time of Day Scheduling

### Digit 30 – External Water & Current-Limit Setpoint

0 = No External Water & Current-Limit Setpoint  
A = External Water & Current-Limit Setpoint - 4–20 mA  
B = External Water & Current-Limit Setpoint - 2–10 Vdc

### Digit 31 – Ice Making

0 = No Ice Making  
A = Ice Making with Relay  
B = Ice Making without Relay

### Digit 32 – Programmable Relays

0 = No Programmable Relays  
A = Programmable Relays

### Digit 33 – Condenser Refrigerant Pressure Output Option

0 = No Condenser Refrigerant Output  
1 = Condenser Water Control Output  
2 = Condenser Pressure (%HPC) Output  
3 = Differential Pressure Output

### Digits 34 – Outdoor Air Temp Sensor

0 = No Outdoor Air Temp Sensor  
A = Outdoor Air Temp Sensor-CWR/Low Ambient

### Digit 35 – Condenser Leaving Hot Water Temp Control

0 = No Condenser Leaving Hot Water Temp Control  
1 = Condenser Leaving Hot Water Temp Control

### Digit 36 – Power Meter

0 = No Power Meter  
P = Power Meter

### Digit 37 – Motor Current Analog Output (%RLA)

0 = No Motor Current Analog Output  
1 = Motor Current Analog Output

### Digit 40 – Installation Accessories

0 = No Installation Accessories  
A = Elastomeric Isolators

### Digit 41 – Flow Switch

0 = No Flow Switch  
1 = 150 psi NEMA 1; Flow Switch x 1  
2 = 150 psi NEMA 1; Flow Switch x 2  
3 = 150 psi NEMA 4; Flow Switch x 1  
4 = 150 psi NEMA 4; Flow Switch x 2

### Digit 42 – 2-Way Water Regulating Valve

0 = No 2-Way Water Regulating Valve  
B = 3" 150 psi/88.9 mm 10.5 bar 220 V  
D = 4" 150 psi/114.3 mm 10.5 bar 220 V

### Digit 44 – Insulation

0 = No Insulation  
1 = Factory Insulation - All Cold Parts  
2 = Insulation for High Humidity

### Digit 45 – Factory Charge

0 = Full Factory Refrigerant Charge (R134a)  
1 = Nitrogen Charge

### Digit 46 – Base Rail Forklifting

0 = No Base Rail Forklifting  
B = Base Rail Forklifting

### Digit 47 – Label and Literature Language

D = English  
F = Chinese - Simple  
G = Chinese - Traditional

### Digit 48 – Special

0 = None  
S = Special

### Digit 49 – 55

0 = None

### Digit 56 – Shipping Package

0 = No Skid (Standard)  
1 = Skid

### Digit 59 – Performance Test Options

0 = No Performance Test  
C = 1 Point Test with Report  
D = 2 Point Test with Report  
E = 3 Point Test with Report  
F = 4 Point Test with Report  
G = Witness 1 Point Test with Report  
H = Witness 2 Point Test with Report  
J = Witness 3 Point Test with Report  
K = Witness 4 Point Test with Report

when Digit 15=F, "1=Standard Cooling" must be chosen for Digit 21.



# General Data

**Table 1. General Data – 50 Hz – standard efficiency**

Size		70	80	90	100	110	120	130	140	150
<b>Compressor</b>										
	Quantity	2	2	2	2	2	2	2	2	2
<b>Evaporator</b>										
Water Storage	(gal)	11.2	12.6	14.0	14.0	14.0	16.2	17.7	17.7	19.1
	(L)	42.2	47.6	53.0	53.0	53.0	61.5	66.8	66.8	72.2
<b>2 Pass Arrangement</b>										
Water Conn. Size	NPS	4	4	4	4	4	5	5	5	5
	(mm)	100	100	100	100	100	125	125	125	125
Minimum Flow	(gpm)	77	89	101	101	101	110	122	122	133
	(L/s)	4.9	5.6	6.4	6.4	6.4	6.9	7.7	7.7	8.4
Maximum Flow	(gpm)	281	324	368	368	368	400	444	444	487
	(L/s)	17.7	20.5	23.2	23.2	23.2	25.2	28.0	28.0	30.7
<b>3 Pass Arrangement</b>										
Water Conn. Size	NPS	3	3	3	3	3	4	4	4	4
	(mm)	80	80	80	80	80	100	100	100	100
Minimum Flow	(gpm)	52	59	67	67	67	73	81	81	89
	(L/s)	3.3	3.8	4.3	4.3	4.3	4.6	5.1	5.1	5.6
Maximum Flow	(gpm)	187	216	244	244	244	266	295	295	324
	(L/s)	11.8	13.6	15.4	15.4	15.4	16.8	18.6	18.6	20.4
<b>Condenser</b>										
Water Storage	(gal)	12.4	14.2	16.0	16.9	16.9	18.5	20.9	20.9	22.4
	(L)	46.8	53.6	60.4	63.8	63.8	70.1	79.2	79.2	84.8
Water Conn. Size	NPS	5	5	5	5	5	5	5	5	5
	(mm)	125	125	125	125	125	125	125	125	125
Minimum Flow	(gpm)	83	99	115	124	124	135	156	156	170
	(L/s)	5.2	6.3	7.3	7.8	7.8	8.5	9.9	9.9	10.8
Maximum Flow	(gpm)	301	361	421	451	451	491	571	571	622
	(L/s)	18.9	22.7	26.5	28.4	28.4	31.0	36.0	36.0	39.2
<b>General Unit</b>										
Refrigerant Type		R-134a	R-134a	R-134a	R-134a	R-134a	R-134a	R-134a	R-134a	R-134a
# Refrig Circuits		2	2	2	2	2	2	2	2	2
Refrigerant Charge	(lb)	114.6/ 114.6	112.4/ 112.4	110.2/ 110.2	110.2/ 112.4	112.4/ 112.4	130.1/ 130.1	127.9/ 127.9	127.9/ 132.3	130.1/ 130.1
	(kg)	52/52	51/51	50/50	50/51	51/51	59/59	58/58	58/60	59/59
Oil Charge	(qt)	7.2/7.2	7.2/7.2	7.2/7.2	7.2/10.5	10.5/10.5	10.5/10.5	10.5/10.5	10.5/10.5	10.5/10.5
	(L)	6.8/6.8	6.8/6.8	6.8/6.8	6.8/9.9	9.9/9.9	9.9/9.9	9.9/9.9	9.9/9.9	9.9/9.9

1. Data containing information on two circuits is shown as circuit 1/circuit 2.  
 2. Flow limits are for water only.

**Table 2. General Data – 50 Hz – high efficiency**

Size		60	70	80	90	100	110	120
<b>Compressor</b>								
	Quantity	2	2	2	2	2	2	2
<b>Evaporator</b>								
Water Storage	(gal)	9.8	10.6	11.9	15.3	15.3	16.4	17.3
	(L)	37.0	40.2	45.2	57.9	57.9	62.3	65.4
<b>2 Pass Arrangement</b>								
Water Conn. Size	NPS	4	4	4	5	5	5	5
	(mm)	100	100	100	125	125	125	125
Minimum Flow	(gpm)	72	80	92	112	112	123	130
	(L/s)	4.6	5.1	5.8	7.1	7.1	7.8	8.2
Maximum Flow	(gpm)	263	291	336	408	408	448	476
	(L/s)	16.6	18.3	21.2	25.8	25.8	28.2	30.0
<b>3 Pass Arrangement</b>								
Water Conn. Size	NPS	3	3	3	4	4	4	4
	(mm)	80	80	80	100	100	100	100
Minimum Flow	(gpm)	48	53	61	75	75	82	86
	(L/s)	3.1	3.4	3.9	4.7	4.7	5.2	5.5
Maximum Flow	(gpm)	175	193	223	271	271	298	316
	(L/s)	11.0	12.2	14.1	17.1	17.1	18.8	19.9
<b>Condenser</b>								
Water Storage	(gal)	11.9	11.9	13.8	15.3	16.6	16.6	18.0
	(L)	45.1	45.1	52.2	58.1	62.7	62.7	68.3
Water Conn. Size	NPS	5	5	5	5	5	5	5
	(mm)	125	125	125	125	125	125	125
Minimum Flow	(gpm)	87	87	106	117	130	130	145
	(L/s)	5.5	5.5	6.7	7.4	8.2	8.2	9.1
Maximum Flow	(gpm)	317	317	387	427	473	473	528
	(L/s)	20.0	20.0	24.4	26.9	29.8	29.8	33.3
<b>General Unit</b>								
Refrigerant Type		R-134a	R-134a	R-134a	R-134a	R-134a	R-134a	R-134a
# Refrig Circuits		2	2	2	2	2	2	2
Refrigerant Charge	(lb)	99.2/99.2	99.2/99.2	97/97	121.3/121.3	121.3/123.5	121.3/121.3	119/119
	(kg)	45/45	45/45	44/44	55/55	55/56	55/55	54/54
Oil Charge	(qt)	7.2/7.2	7.2/7.2	7.2/7.2	7.2/7.2	7.2/10.5	10.5/10.5	10.5/10.5
	(L)	6.8/6.8	6.8/6.8	6.8/6.8	6.8/6.8	6.8/9.9	9.9/9.9	9.9/9.9

1. Data containing information on two circuits is shown as circuit 1/circuit 2.  
2. Flow limits are for water only.



## General Data

**Table 3. General Data – 50 Hz – high efficiency (continued)**

Size		130	140	160	180	200	220	250
<b>Compressor</b>								
	Quantity	2	2	2	2	2	2	2
<b>Evaporator</b>								
Water Storage	(gal)	18.8	20.0	22.0	23.8	27.9	29.2	31.0
	(L)	71.2	75.6	83.2	90.1	105.5	110.5	117.5
<b>2 Pass Arrangement</b>								
Water Conn. Size	NPS	5	5	5	5	6	6	6
	(mm)	125	125	125	125	150	150	150
Minimum Flow	(gpm)	141	151	170	186	211	223	240
	(L/s)	8.9	9.5	10.7	11.8	13.3	14.1	15.1
Maximum Flow	(gpm)	515	555	622	683	773	818	879
	(L/s)	32.5	35.0	39.2	43.1	48.8	51.6	55.5
<b>3 Pass Arrangement</b>								
Water Conn. Size	NPS	4	4	4	4	4	4	4
	(mm)	100	100	100	100	100	100	100
Minimum Flow	(gpm)	94	101	113	124	141	149	160
	(L/s)	5.9	6.4	7.1	7.8	8.9	9.4	10.1
Maximum Flow	(gpm)	344	370	415	456	515	545	586
	(L/s)	21.7	23.3	26.2	28.7	32.5	34.4	37.0
<b>Condenser</b>								
Water Storage	(gal)	21.6	22.9	24.6	26.2	31.1	31.1	35.2
	(L)	81.7	86.8	93.0	99.2	117.8	117.8	133.3
Water Conn. Size	NPS	6	6	6	6	6	6	6
	(mm)	150	150	150	150	150	150	150
Minimum Flow	(gpm)	159	173	189	206	244	244	286
	(L/s)	10.0	10.9	11.9	13.0	15.4	15.4	18.0
	(gpm)	584	634	695	755	896	896	1047
	(L/s)	36.8	40.0	43.8	47.6	56.5	56.5	66.1
<b>General Unit</b>								
Refrigerant Type		R-134a	R-134a	R-134a	R-134a	R-134a	R-134a	R-134a
# Refrig Circuits		2	2	2	2	2	2	2
Refrigerant Charge	(lb)	134.5/134.5	132.3/136.7	134.5/134.5	132.3/136.7	178.6/178.6	176.4/183.0	180.8/180.8
	(kg)	61/61	60/62	61/61	60/62	81/81	80/83	82/82
Oil Charge	(qt)	10.5/10.5	10.5/10.5	10.5/10.5	10.5/12.4	12.4/12.4	12.4/12.4	12.4/12.4
	(L)	9.9/9.9	9.9/9.9	9.9/9.9	9.9/11.7	11.7/11.7	11.7/11.7	11.7/11.7

1. Data containing information on two circuits is shown as circuit 1/circuit 2.
2. Flow limits are for water only.

**Table 4. General Data – 50 Hz – premium efficiency**

<b>Size</b>		<b>160</b>	<b>180</b>	<b>200</b>
<b>Compressor</b>				
	Quantity	2	2	2
<b>Evaporator</b>				
Water Storage	(gal)	28.6	30.6	31.0
	(L)	108.3	115.7	117.5
<b>2 Pass Arrangement</b>				
Water Conn. Size	NPS	6	6	6
	(mm)	150	150	150
Minimum Flow	(gpm)	186	202	240
	(L/s)	11.8	12.7	15.1
Maximum Flow	(gpm)	683	739	879
	(L/s)	43.1	46.7	55.5
<b>3 Pass Arrangement</b>				
Water Conn. Size	NPS	4	4	4
	(mm)	100	100	100
Minimum Flow	(gpm)	124	134	160
	(L/s)	7.8	8.5	10.1
Maximum Flow	(gpm)	456	493	586
	(L/s)	28.7	31.1	37.0
<b>Condenser</b>				
Water Storage	(gal)	30.0	34.5	39.2
	(L)	113.4	130.6	148.3
Water Conn. Size	NPS	6	6	6
	(mm)	150	150	150
Minimum Flow	(gpm)	206	244	325
	(L/s)	13.0	15.4	20.5
	(gpm)	755	896	1193
	(L/s)	47.6	56.5	75.3
<b>General Unit</b>				
Refrigerant Type		R-134a	R-134a	R-134a
# Refrig Circuits		2	2	2
Refrigerant Charge	(lb)	176.4/176.4	176.2/178.6	176.4/174.2
	(kg)	80/80	79/81	80/79
Oil Charge	(qt)	10.5/10.5	10.5/12.4	12.4/12.4
	(L)	9.9/9.9	9.9/11.7	11.7/11.7

1. Data containing information on two circuits is shown as circuit 1/circuit 2.
2. Flow limits are for water only.



# Performance Data

Table 5. Performance Data - 50 Hz - standard efficiency - I-P units

Evaporator Leaving Water Temperature (°F)	Unit Size	Condenser Entering Water Temperature (°F)											
		75				85				95			
		Tons	kW Input	EER	kW/ton	Tons	kW Input	EER	kW/ton	Tons	kW Input	EER	kW/ton
40	70	72.5	46.5	18.6	0.646	68.0	52.7	15.4	0.780	63.2	59.9	12.6	0.955
	80	83.2	54.0	18.4	0.654	77.9	61.2	15.2	0.791	72.2	69.7	12.4	0.970
	90	94.6	61.3	18.4	0.652	88.5	69.4	15.2	0.789	82.0	79.0	12.4	0.968
	100	100.6	65.0	18.5	0.650	94.3	73.7	15.3	0.786	87.6	83.9	12.5	0.963
	110	106.6	69.0	18.4	0.651	100.1	78.4	15.3	0.787	93.2	89.2	12.5	0.962
	120	119.7	76.5	18.7	0.642	112.4	86.8	15.5	0.776	104.5	98.7	12.7	0.948
	130	130.1	82.0	18.9	0.634	122.2	93.1	15.7	0.766	113.7	106.0	12.8	0.935
	140	140.3	89.5	18.7	0.641	132.0	101.4	15.6	0.772	123.2	115.2	12.8	0.939
	150	152.4	96.1	18.9	0.633	143.5	108.6	15.8	0.759	134.3	123.2	13.0	0.921
42	70	75.4	46.8	19.2	0.625	70.8	52.9	15.9	0.753	65.8	60.2	13.0	0.920
	80	86.6	54.3	19.0	0.632	81.1	61.5	15.7	0.763	75.3	69.9	12.9	0.933
	90	98.4	61.7	19.0	0.631	92.2	69.8	15.8	0.761	85.5	79.2	12.9	0.931
	100	104.6	65.3	19.1	0.628	98.2	74.0	15.8	0.758	91.3	84.1	13.0	0.926
	110	110.9	69.3	19.1	0.629	104.2	78.6	15.8	0.759	97.0	89.4	13.0	0.925
	120	124.6	76.9	19.3	0.621	117.0	87.1	16.0	0.748	108.9	98.9	13.2	0.912
	130	135.3	82.5	19.6	0.613	127.2	93.5	16.3	0.738	118.5	106.1	13.4	0.899
	140	145.9	90.1	19.3	0.620	137.4	101.9	16.1	0.745	128.3	115.6	13.3	0.904
	150	158.5	96.8	19.6	0.613	149.4	109.2	16.4	0.733	139.9	123.7	13.5	0.887
44	70	78.4	47.1	19.8	0.606	73.6	53.2	16.5	0.728	68.6	60.4	13.5	0.887
	80	90.0	54.7	19.6	0.612	84.4	61.8	16.3	0.737	78.5	70.2	13.3	0.899
	90	102.2	62.1	19.6	0.611	95.9	70.1	16.3	0.735	89.1	79.5	13.4	0.897
	100	108.7	65.7	19.7	0.608	102.1	74.3	16.4	0.732	95.1	84.4	13.5	0.892
	110	115.2	69.7	19.7	0.608	108.3	78.9	16.4	0.732	101.0	89.6	13.5	0.891
	120	129.5	77.4	20.0	0.601	121.7	87.5	16.6	0.722	113.4	99.2	13.7	0.878
	130	140.7	83.0	20.2	0.593	132.3	93.8	16.9	0.712	123.4	106.3	13.9	0.865
	140	151.6	90.7	20.0	0.601	142.9	102.4	16.7	0.719	133.6	116.0	13.8	0.871
	150	164.8	97.5	20.2	0.594	155.5	109.8	16.9	0.709	145.7	124.3	14.0	0.856
46	70	81.4	47.4	20.4	0.587	76.5	53.5	17.0	0.705	71.3	60.7	14.0	0.856
	80	93.4	55.1	20.2	0.594	87.8	62.2	16.8	0.713	81.7	70.5	13.8	0.867
	90	106.2	62.5	20.3	0.593	99.7	70.5	16.9	0.711	92.8	79.8	13.9	0.865
	100	112.9	66.1	20.4	0.589	106.1	74.7	17.0	0.707	98.9	84.6	14.0	0.860
	110	119.6	70.1	20.4	0.589	112.6	79.2	17.0	0.708	105.0	89.9	14.0	0.859
	120	134.6	77.9	20.6	0.582	126.6	88.0	17.2	0.698	118.0	99.5	14.2	0.846
	130	146.1	83.5	20.9	0.574	137.6	94.2	17.5	0.688	128.4	106.6	14.4	0.833
	140	157.5	91.4	20.6	0.582	148.5	102.9	17.3	0.696	139.0	116.4	14.3	0.840
	150	171.3	98.3	20.8	0.576	161.7	110.5	17.5	0.686	151.6	124.9	14.5	0.826



## Performance Data

**Table 5. Performance Data - 50 Hz - standard efficiency - I-P units**

Evaporator Leaving Water Temperature (°F)	Unit Size	Condenser Entering Water Temperature (°F)											
		75				85				95			
		Tons	kW Input	EER	kW/ton	Tons	kW Input	EER	kW/ton	Tons	kW Input	EER	kW/ton
<b>48</b>	<b>70</b>	84.5	47.8	21.0	0.570	79.5	53.9	17.6	0.683	74.2	61.0	14.5	0.828
	<b>80</b>	97.0	55.5	20.8	0.576	91.2	62.5	17.4	0.690	85.0	70.8	14.3	0.838
	<b>90</b>	110.2	63.0	20.9	0.575	103.6	70.9	17.4	0.688	96.5	80.2	14.4	0.835
	<b>100</b>	117.1	66.6	21.0	0.572	110.2	75.0	17.5	0.684	102.9	84.9	14.5	0.830
	<b>110</b>	124.1	70.5	21.0	0.571	116.9	79.6	17.5	0.684	109.2	90.1	14.5	0.829
	<b>120</b>	139.8	78.5	21.3	0.564	131.6	88.4	17.8	0.675	122.8	99.9	14.7	0.817
	<b>130</b>	151.7	84.0	21.6	0.556	143.0	94.6	18.1	0.665	133.6	106.9	14.9	0.803
	<b>140</b>	163.6	92.0	21.2	0.565	154.3	103.5	17.8	0.673	144.6	116.9	14.8	0.811
	<b>150</b>	177.9	99.1	21.4	0.560	168.0	111.2	18.1	0.664	157.7	125.5	15.0	0.799
<b>50</b>	<b>70</b>	87.7	48.2	21.7	0.554	82.6	54.2	18.1	0.662	77.1	61.3	15.0	0.801
	<b>80</b>	100.6	55.9	21.4	0.560	94.7	62.9	17.9	0.669	88.3	71.1	14.8	0.810
	<b>90</b>	114.3	63.5	21.5	0.559	107.5	71.3	18.0	0.667	100.4	80.6	14.9	0.807
	<b>100</b>	121.5	67.0	21.6	0.555	114.4	75.4	18.1	0.663	106.9	85.3	15.0	0.802
	<b>110</b>	128.7	70.9	21.6	0.554	121.3	80.0	18.1	0.663	113.4	90.5	15.0	0.801
	<b>120</b>	145.1	79.1	21.9	0.548	136.7	88.9	18.4	0.654	127.6	100.3	15.2	0.789
	<b>130</b>	157.5	84.6	22.2	0.540	148.5	95.1	18.7	0.643	138.9	107.2	15.5	0.775
	<b>140</b>	169.7	92.8	21.9	0.549	160.3	104.2	18.4	0.652	150.2	117.4	15.3	0.784
	<b>150</b>	184.6	100.0	22.1	0.544	174.5	112.0	18.6	0.644	163.9	126.2	15.5	0.773

1. Rated in accordance with ARI Standard 550/590, based on an evaporator temperature drop of 5.6°C, 3 gpm/ton on the condenser, evaporator fouling factor of 0.01761°K·m<sup>3</sup>/kW and condenser fouling of 0.044025°K·m<sup>3</sup>/kW.
2. Performance is based on 2 pass evaporator configuration.
3. Consult Trane representative for additional performance information.
4. kW input is for compressors only.
5. COP—Coefficient of Performance. Power inputs include compressors and control power.
7. Interpolation between points is permissible. Extrapolation is not permitted.



## Performance Data

**Table 6. Performance Data - 50 Hz - high efficiency - I-P units**

Evaporator Leaving Water Temperature (°F)	Unit Size	Condenser Entering Water Temperature (°F)											
		75				85				95			
		Tons	kW Input	EER	kW/ton	Tons	kW input	EER	kW/ton	Tons	kW input	EER	kW/ton
<b>38</b>	<b>60</b>	63.0	38.7	19.4	0.620	58.8	43.9	15.9	0.753	54.4	50.0	13.0	0.926
	<b>70</b>	74.3	45.5	19.4	0.617	69.6	51.5	16.1	0.746	64.6	58.6	13.1	0.913
	<b>80</b>	85.2	52.9	19.2	0.625	79.7	59.9	15.9	0.756	73.8	68.1	12.9	0.928
	<b>90</b>	98.0	60.3	19.4	0.620	91.6	68.3	16.0	0.750	84.6	77.6	13.0	0.921
	<b>100</b>	104.6	63.8	19.5	0.614	97.8	72.3	16.1	0.743	90.7	82.3	13.2	0.912
	<b>110</b>	111.9	67.7	19.7	0.608	104.8	76.7	16.3	0.736	97.3	87.3	13.3	0.902
	<b>120</b>	121.2	73.8	19.6	0.612	113.6	83.8	16.2	0.741	105.6	95.4	13.2	0.907
	<b>130</b>	130.8	80.2	19.5	0.616	122.8	91.1	16.1	0.745	114.3	103.7	13.2	0.910
	<b>140</b>	142.2	86.9	19.5	0.614	133.7	98.4	16.2	0.739	124.7	111.8	13.3	0.900
	<b>160</b>	154.7	93.4	19.8	0.606	145.6	105.5	16.5	0.727	136.0	119.7	13.6	0.883
	<b>180</b>	170.5	104.1	19.6	0.613	160.3	117.8	16.3	0.738	149.6	133.9	13.4	0.898
	<b>200</b>	187.3	114.1	19.6	0.611	176.1	129.5	16.3	0.737	164.2	147.3	13.3	0.900
	<b>220</b>	204.8	126.7	19.3	0.621	192.9	142.5	16.2	0.741	180.3	161.0	13.4	0.895
<b>250</b>	223.8	138.3	19.4	0.620	211.2	154.2	16.4	0.732	197.9	173.1	13.7	0.877	
<b>40</b>	<b>60</b>	65.7	38.8	20.1	0.597	61.4	44.0	16.6	0.723	56.9	50.0	13.5	0.886
	<b>70</b>	77.4	45.8	20.1	0.596	72.6	51.7	16.7	0.718	67.4	58.8	13.7	0.878
	<b>80</b>	88.7	53.2	19.9	0.604	83.1	60.1	16.5	0.728	77.1	68.3	13.5	0.892
	<b>90</b>	102.1	60.7	20.0	0.599	95.5	68.6	16.6	0.722	88.4	77.8	13.6	0.884
	<b>100</b>	108.9	64.2	20.2	0.593	102.1	72.6	16.8	0.715	94.7	82.5	13.7	0.875
	<b>110</b>	116.6	68.0	20.5	0.586	109.3	77.0	17.0	0.708	101.6	87.5	13.9	0.865
	<b>120</b>	126.3	74.2	20.3	0.590	118.5	84.0	16.8	0.712	110.2	95.5	13.8	0.870
	<b>130</b>	136.2	80.6	20.2	0.595	128.0	91.3	16.7	0.717	119.3	103.8	13.7	0.874
	<b>140</b>	148.1	87.4	20.2	0.593	139.3	98.7	16.9	0.711	130.1	112.0	13.9	0.864
	<b>160</b>	161.1	94.0	20.5	0.586	151.8	105.9	17.1	0.700	141.9	120.0	14.1	0.848
	<b>180</b>	177.6	104.7	20.3	0.592	167.1	118.3	16.9	0.710	156.1	134.2	13.9	0.862
	<b>200</b>	195.1	114.7	20.3	0.590	183.6	129.9	16.9	0.710	171.4	147.5	13.9	0.863
	<b>220</b>	213.1	127.7	20.0	0.601	201.0	143.3	16.8	0.715	188.1	161.6	13.9	0.861
<b>250</b>	232.8	139.7	19.9	0.602	219.9	155.3	16.9	0.708	206.3	174.0	14.2	0.845	

## Performance Data

**Table 6. Performance Data - 50 Hz - high efficiency - I-P units**

Evaporator Leaving Water Temperature (°F)	Unit Size	Condenser Entering Water Temperature (°F)											
		75				85				95			
		Tons	kW Input	EER	kW/ton	Tons	kW input	EER	kW/ton	Tons	kW input	EER	kW/ton
<b>42</b>	<b>60</b>	68.4	39.0	20.8	0.576	64.1	44.2	17.3	0.695	59.5	50.1	14.1	0.849
	<b>70</b>	80.5	46.1	20.8	0.577	75.6	52.0	17.3	0.693	70.3	59.0	14.2	0.845
	<b>80</b>	92.3	53.5	20.5	0.584	86.6	60.4	17.1	0.702	80.4	68.5	14.0	0.857
	<b>90</b>	106.3	61.1	20.7	0.579	99.6	68.9	17.2	0.696	92.3	78.1	14.1	0.850
	<b>100</b>	113.4	64.6	21.0	0.573	106.4	72.9	17.4	0.689	98.8	82.7	14.3	0.840
	<b>110</b>	121.5	68.4	21.2	0.566	114.0	77.3	17.6	0.682	106.0	87.6	14.4	0.831
	<b>120</b>	131.5	74.5	21.1	0.570	123.5	84.3	17.5	0.686	115.0	95.6	14.4	0.835
	<b>130</b>	141.7	81.0	20.9	0.574	133.3	91.6	17.4	0.690	124.3	103.9	14.3	0.839
	<b>140</b>	154.1	87.8	21.0	0.573	145.1	99.1	17.5	0.686	135.6	112.3	14.4	0.831
	<b>160</b>	167.7	94.6	21.2	0.566	158.1	106.4	17.8	0.676	148.0	120.4	14.7	0.816
	<b>180</b>	184.9	105.3	21.0	0.572	174.1	118.8	17.5	0.684	162.8	134.6	14.5	0.829
	<b>200</b>	203.0	115.3	21.0	0.570	191.2	130.3	17.6	0.684	178.7	147.8	14.5	0.829
	<b>220</b>	221.7	128.7	20.6	0.583	209.2	144.1	17.4	0.691	196.0	162.2	14.5	0.829
<b>250</b>	242.0	141.1	20.5	0.585	228.8	156.5	17.5	0.686	214.9	174.9	14.7	0.816	
<b>44</b>	<b>60</b>	71.3	39.2	21.6	0.556	66.8	44.3	17.9	0.669	62.1	50.2	14.7	0.815
	<b>70</b>	83.8	46.4	21.5	0.559	78.7	52.3	17.9	0.670	73.3	59.2	14.7	0.814
	<b>80</b>	96.0	53.9	21.2	0.565	90.1	60.7	17.7	0.678	83.8	68.8	14.5	0.826
	<b>90</b>	110.6	61.6	21.4	0.560	103.7	69.2	17.9	0.672	96.3	78.3	14.7	0.817
	<b>100</b>	118.0	65.0	21.7	0.554	110.8	73.2	18.1	0.664	103.1	82.9	14.8	0.808
	<b>110</b>	126.4	68.8	21.9	0.547	118.7	77.6	18.3	0.657	110.5	87.9	15.0	0.799
	<b>120</b>	136.8	75.0	21.8	0.551	128.6	84.6	18.2	0.661	119.8	95.8	14.9	0.803
	<b>130</b>	147.4	81.4	21.6	0.555	138.8	91.9	18.0	0.665	129.5	104.1	14.9	0.807
	<b>140</b>	160.2	88.4	21.7	0.554	151.1	99.5	18.1	0.661	141.3	112.6	15.0	0.800
	<b>160</b>	174.5	95.3	21.9	0.548	164.6	106.9	18.4	0.652	154.2	120.8	15.3	0.786
	<b>180</b>	192.3	106.0	21.7	0.553	181.3	119.3	18.2	0.660	169.7	134.9	15.0	0.798
	<b>200</b>	211.1	116.0	21.8	0.551	199.0	130.8	18.2	0.659	186.3	148.2	15.0	0.798
	<b>220</b>	230.4	129.8	21.2	0.565	217.6	145.0	18.0	0.668	204.2	162.9	15.0	0.800
<b>250</b>	251.4	142.6	21.1	0.569	237.9	157.9	18.0	0.665	223.7	176.0	15.2	0.789	



## Performance Data

**Table 6. Performance Data - 50 Hz - high efficiency - I-P units**

Evaporator Leaving Water Temperature (°F)	Unit Size	Condenser Entering Water Temperature (°F)											
		75				85				95			
		Tons	kW Input	EER	kW/ton	Tons	kW input	EER	kW/ton	Tons	kW input	EER	kW/ton
<b>46</b>	<b>60</b>	74.1	39.5	22.3	0.538	69.6	44.5	18.6	0.645	64.8	50.3	15.3	0.783
	<b>70</b>	87.0	46.7	22.2	0.541	81.8	52.6	18.5	0.647	76.3	59.5	15.3	0.785
	<b>80</b>	99.8	54.3	21.9	0.548	93.7	61.0	18.3	0.655	87.3	69.1	15.1	0.796
	<b>90</b>	115.0	62.0	22.1	0.543	107.9	69.6	18.5	0.649	100.4	78.7	15.2	0.787
	<b>100</b>	122.7	65.4	22.4	0.536	115.3	73.6	18.7	0.641	107.4	83.2	15.4	0.778
	<b>110</b>	131.4	69.2	22.7	0.529	123.6	77.9	18.9	0.634	115.1	88.1	15.6	0.769
	<b>120</b>	142.2	75.4	22.5	0.533	133.9	84.9	18.8	0.638	124.8	96.0	15.5	0.773
	<b>130</b>	153.1	81.9	22.3	0.537	144.3	92.3	18.7	0.642	134.8	104.3	15.5	0.776
	<b>140</b>	166.5	88.9	22.4	0.536	157.1	100.0	18.8	0.639	147.1	112.9	15.6	0.770
	<b>160</b>	181.4	96.0	22.6	0.531	171.2	107.5	19.0	0.630	160.6	121.3	15.8	0.758
	<b>180</b>	200.0	106.7	22.4	0.536	188.6	119.9	18.8	0.638	176.7	135.4	15.6	0.768
	<b>200</b>	219.4	116.7	22.5	0.534	207.0	131.4	18.8	0.637	194.0	148.5	15.6	0.768
	<b>220</b>	239.3	131.0	21.9	0.549	226.2	146.0	18.5	0.647	212.5	163.7	15.5	0.772
	<b>250</b>	261.0	144.2	21.7	0.554	247.2	159.2	18.6	0.646	232.7	177.2	15.7	0.763
<b>48</b>	<b>60</b>	77.1	39.7	23.1	0.520	72.4	44.7	19.3	0.623	67.6	50.5	15.9	0.753
	<b>70</b>	90.4	47.1	22.8	0.525	85.1	52.9	19.2	0.627	79.4	59.8	15.8	0.758
	<b>80</b>	103.6	54.7	22.6	0.532	97.5	61.4	18.9	0.634	90.9	69.4	15.6	0.768
	<b>90</b>	119.4	62.5	22.8	0.527	112.3	70.0	19.1	0.627	104.6	79.0	15.8	0.759
	<b>100</b>	127.5	65.8	23.1	0.520	119.9	73.9	19.4	0.620	111.8	83.5	16.0	0.750
	<b>110</b>	136.6	69.6	23.4	0.513	128.6	78.3	19.6	0.612	119.9	88.4	16.2	0.741
	<b>120</b>	147.8	75.8	23.3	0.516	139.2	85.3	19.5	0.616	130.0	96.3	16.1	0.744
	<b>130</b>	159.0	82.3	23.1	0.520	150.0	92.6	19.4	0.620	140.3	104.5	16.0	0.748
	<b>140</b>	173.0	89.5	23.1	0.520	163.4	100.5	19.4	0.617	153.1	113.3	16.2	0.743
	<b>160</b>	188.5	96.7	23.3	0.515	178.1	108.2	19.7	0.610	167.2	121.9	16.4	0.731
	<b>180</b>	207.8	107.5	23.1	0.519	196.2	120.5	19.5	0.616	184.0	135.9	16.2	0.741
	<b>200</b>	227.8	117.5	23.2	0.517	215.2	132.0	19.5	0.615	201.8	149.0	16.2	0.740
	<b>220</b>	248.3	132.2	22.5	0.534	235.0	147.0	19.1	0.627	221.0	164.5	16.1	0.746
	<b>250</b>	270.8	145.9	22.2	0.540	256.7	160.7	19.1	0.628	241.8	178.4	16.2	0.739

Table 6. Performance Data - 50 Hz - high efficiency - I-P units

Evaporator Leaving Water Temperature (°F)	Unit Size	Condenser Entering Water Temperature (°F)											
		75				85				95			
		Tons	kW Input	EER	kW/ton	Tons	kW input	EER	kW/ton	Tons	kW input	EER	kW/ton
50	60	80.1	39.9	23.8	0.504	75.3	44.9	20.0	0.601	70.4	50.6	16.5	0.726
	70	93.9	47.5	23.5	0.510	88.4	53.3	19.8	0.607	82.6	60.1	16.4	0.733
	80	107.5	55.1	23.2	0.516	101.3	61.8	19.5	0.614	94.5	69.7	16.2	0.741
	90	124.0	63.0	23.5	0.511	116.7	70.5	19.8	0.607	108.9	79.4	16.4	0.733
	100	132.4	66.3	23.8	0.504	124.7	74.4	20.0	0.600	116.4	83.8	16.6	0.723
	110	141.9	70.1	24.1	0.497	133.7	78.7	20.3	0.592	124.8	88.7	16.8	0.714
	120	153.5	76.3	24.0	0.500	144.7	85.7	20.2	0.595	135.2	96.6	16.7	0.717
	130	165.0	82.8	23.8	0.504	155.9	93.0	20.0	0.599	145.9	104.8	16.6	0.721
	140	179.6	90.2	23.8	0.504	169.7	101.0	20.1	0.597	159.2	113.7	16.7	0.717
	160	195.7	97.6	24.0	0.501	185.0	108.9	20.3	0.591	173.9	122.4	17.0	0.707
	180	215.8	108.3	23.8	0.504	203.9	121.2	20.1	0.596	191.4	136.4	16.8	0.715
	200	236.4	118.3	23.9	0.502	223.5	132.6	20.2	0.595	209.9	149.5	16.8	0.714
	220	257.6	133.4	23.1	0.519	244.0	148.1	19.7	0.609	229.6	165.4	16.6	0.722
	250	280.8	147.6	22.8	0.527	266.4	162.3	19.7	0.611	251.2	179.8	16.7	0.717

1. Rated in accordance with ARI Standard 550/590, based on evaporator temperature drop of 10°F, 3 gpm/ton on the condenser, evaporator fouling factor of 0.0001°F·ft<sup>2</sup>·h/Btu and condenser fouling factor of 0.00025°F·ft<sup>2</sup>·h/Btu.
2. Performance is based on 2 pass evaporator configuration.
3. Consult Trane representative for additional performance information.
4. kW input is for compressors only.
5. EER – Energy Efficiency Ratio (Btu/W·h). Power inputs include compressors and control power.
6. Interpolation between points is permissible. Extrapolation is not permitted.



## Performance Data

**Table 7. Performance Data - 50 Hz - premium efficiency - I-P units**

Leaving Water Temperature (°F)	Unit Size	Condenser Entering Water Temperature (°F)											
		75				85				95			
		Tons	kW input	EER	kW/ton	Tons	kW input	EER	kW/ton	Tons	kW input	EER	kW/ton
38	160	159.3	92.4	20.6	0.582	149.7	104.1	17.2	0.698	139.8	118.1	14.1	0.848
	180	175.6	102.4	20.5	0.586	164.9	115.8	17.0	0.705	153.7	131.6	14.0	0.859
	200	189.1	112.5	20.1	0.597	177.7	127.6	16.7	0.720	165.6	145.2	13.7	0.879
40	160	166.1	92.9	21.3	0.562	156.2	104.6	17.9	0.672	146.0	118.4	14.7	0.814
	180	183.1	103.0	21.3	0.565	172.1	116.2	17.7	0.678	160.6	131.9	14.6	0.824
	200	197.1	113.0	20.9	0.575	185.4	127.9	17.3	0.692	173.0	145.4	14.2	0.843
42	160	173.1	93.6	22.1	0.543	162.9	105.1	18.5	0.647	152.4	118.8	15.3	0.782
	180	190.8	103.6	22.0	0.545	179.5	116.7	18.4	0.652	167.7	132.2	15.2	0.791
	200	205.3	113.6	21.6	0.555	193.2	128.3	18.0	0.666	180.5	145.6	14.8	0.809
44	160	180.2	94.3	22.8	0.525	169.8	105.6	19.2	0.624	159.0	119.2	15.9	0.753
	180	198.7	104.3	22.8	0.527	187.1	117.2	19.1	0.629	174.9	132.5	15.8	0.760
	200	213.6	114.2	22.4	0.537	201.3	128.8	18.7	0.642	188.2	145.9	15.4	0.777
46	160	187.6	95.0	23.6	0.509	176.9	106.2	19.9	0.603	165.7	119.7	16.6	0.725
	180	206.8	105.0	23.5	0.510	194.9	117.8	19.8	0.606	182.4	132.9	16.4	0.731
	200	222.1	114.9	23.1	0.519	209.5	129.3	19.4	0.619	196.2	146.2	16.1	0.747
48	160	195.2	95.8	24.3	0.493	184.2	106.9	20.6	0.583	172.7	120.2	17.2	0.699
	180	215.2	105.8	24.3	0.494	202.9	118.4	20.5	0.585	190.1	133.4	17.1	0.704
	200	230.8	115.7	23.9	0.503	217.9	129.9	20.1	0.598	204.2	146.6	16.7	0.720
50	160	202.9	96.7	25.1	0.479	191.6	107.6	21.3	0.564	179.8	120.8	17.8	0.674
	180	223.7	106.7	25.1	0.479	211.2	119.1	21.2	0.566	198.0	133.9	17.7	0.678
	200	239.7	116.5	24.6	0.488	226.5	130.5	20.8	0.578	212.5	147.1	17.3	0.694

1. Rated in accordance with ARI Standard 550/590, based on evaporator temperature drop of 10°F, 3 gpm/ton on the condenser, evaporator fouling factor of 0.0001°F·ft<sup>2</sup>·h/Btu and condenser fouling factor of 0.00025°F·ft<sup>2</sup>·h/Btu.
2. Performance is based on 2 pass evaporator configuration.
3. Consult Trane representative for additional performance information.
4. kW input is for compressors only.
5. EER – Energy Efficiency Ratio (Btu/W·h). Power inputs include compressors and control power.
6. Interpolation between points is permissible. Extrapolation is not permitted.

## Performance Data

**Table 8. Part Load Performance – 50 Hz – standard efficiency – I-P units**

Unit Size	% Load	Tons	kW	EER	kW/ton	IPLV	
						EER	kW/ton
<b>70</b>	100	73.6	53.6	16.5	0.728	22.3	0.539
	75	55.2	32.3	20.5	0.585		
	50	36.8	18.1	24.4	0.492		
	25	18.4	10.5	21.0	0.568		
<b>80</b>	100	84.4	62.2	16.3	0.737	22.4	0.536
	75	63.3	37.8	20.1	0.597		
	50	42.2	21.0	24.1	0.497		
	25	21.1	10.5	24.1	0.495		
<b>90</b>	100	95.9	70.5	16.3	0.735	22.1	0.544
	75	71.9	43.1	20.0	0.599		
	50	48.0	23.7	24.3	0.494		
	25	24.0	13.5	21.3	0.564		
<b>100</b>	100	102.1	74.7	16.4	0.732	22.2	0.540
	75	76.6	45.9	20.0	0.600		
	50	51.0	25.2	24.3	0.493		
	25	25.5	13.6	22.5	0.534		
<b>110</b>	100	108.3	79.3	16.4	0.732	21.7	0.552
	75	81.2	49.2	19.8	0.605		
	50	54.2	27.0	24.1	0.499		
	25	27.1	16.3	20.0	0.600		
<b>120</b>	100	121.7	87.9	16.6	0.722	22.3	0.537
	75	91.3	54.9	20.0	0.601		
	50	60.9	29.6	24.7	0.486		
	25	30.4	16.3	22.4	0.536		
<b>130</b>	100	132.3	94.2	16.9	0.712	22.3	0.537
	75	99.3	59.3	20.1	0.597		
	50	66.2	31.7	25.1	0.479		
	25	33.1	19.5	20.4	0.591		
<b>140</b>	100	142.9	102.8	16.7	0.719	22.3	0.538
	75	107.2	64.0	20.1	0.597		
	50	71.4	34.7	24.7	0.486		
	25	35.7	19.8	21.6	0.555		
<b>150</b>	100	155.5	110.2	16.9	0.709	22.3	0.538
	75	116.6	68.2	20.5	0.585		
	50	77.7	37.9	24.6	0.488		
	25	38.9	22.7	20.6	0.585		

1. Rated in accordance with ARI Standard 550/590, based on evaporator temperature drop of 10°F, 3 gpm/ton on the condenser, evaporator fouling factor of 0.0001°F·ft<sup>2</sup>·h/Btu and condenser fouling factor of 0.00025°F·ft<sup>2</sup>·h/Btu.

2. Performance is based on 2 pass evaporator configuration.

3. Consult Trane representative for additional performance information.

4. kW input is for compressors only.

5. EER – Energy Efficiency Ratio (Btu/W·h). Power inputs include compressors and control power.



## Performance Data

**Table 9. Part Load Performance – 50 Hz – high efficiency – I-P units**

Unit Size	% Load	Tons	kW	EER	kW/ton	IPLV	
						EER	kW/ton
<b>60</b>	100	66.8	44.7	17.9	0.669	24.4	0.492
	75	50.1	27.3	22.1	0.544		
	50	33.4	14.8	27.1	0.442		
	25	16.7	8.8	22.8	0.527		
<b>70</b>	100	78.7	52.7	17.9	0.670	24.2	0.495
	75	59.0	31.7	22.3	0.538		
	50	39.3	17.8	26.5	0.453		
	25	19.7	10.2	23.2	0.519		
<b>80</b>	100	90.1	61.1	17.7	0.678	24.5	0.491
	75	67.6	37.1	21.9	0.549		
	50	45.0	20.4	26.5	0.452		
	25	22.5	10.3	26.2	0.457		
<b>90</b>	100	103.7	69.6	17.9	0.672	24.2	0.496
	75	77.8	42.4	22.0	0.546		
	50	51.8	23.4	26.6	0.451		
	25	25.9	13.3	23.4	0.514		
<b>100</b>	100	110.8	73.6	18.0	0.664	24.6	0.488
	75	83.1	45.2	22.1	0.544		
	50	55.4	24.5	27.1	0.443		
	25	27.7	13.5	24.6	0.486		
<b>110</b>	100	118.7	78.0	18.3	0.657	24.2	0.495
	75	89.0	48.3	22.1	0.542		
	50	59.3	26.5	26.8	0.447		
	25	29.7	15.9	22.4	0.536		
<b>120</b>	100	128.6	85.0	18.2	0.661	24.3	0.494
	75	96.5	53.0	21.8	0.550		
	50	64.3	28.8	26.8	0.448		
	25	32.2	16.0	24.2	0.496		
<b>130</b>	100	138.8	92.3	18.0	0.665	23.9	0.502
	75	104.1	58.0	21.5	0.558		
	50	69.4	31.0	26.8	0.446		
	25	34.7	19.1	21.8	0.552		
<b>140</b>	100	151.1	99.9	18.2	0.661	24.3	0.494
	75	113.3	62.3	21.8	0.550		
	50	75.5	33.6	27.0	0.444		
	25	37.8	19.3	23.5	0.512		
<b>160</b>	100	164.6	107.3	18.4	0.652	24.3	0.495
	75	123.4	66.4	22.3	0.538		
	50	82.3	37.0	26.7	0.450		
	25	41.2	22.0	22.5	0.536		



**Table 9. Part Load Performance – 50 Hz – high efficiency – I-P units**

Unit Size	% Load	Tons	kW	EER	kW/ton	IPLV	
						EER	kW/ton
<b>180</b>	100	181.3	119.7	18.2	0.660	24.4	0.491
	75	136.0	74.8	21.8	0.550		
	50	90.7	40.3	27.0	0.445		
	25	45.3	22.2	24.5	0.490		
<b>200</b>	100	199.0	131.2	18.2	0.659	24.1	0.499
	75	149.3	82.6	21.7	0.553		
	50	99.5	44.2	27.0	0.445		
	25	49.8	27.5	21.7	0.552		
<b>220</b>	100	217.6	145.4	18.0	0.668	24.0	0.501
	75	163.2	89.6	21.9	0.549		
	50	108.8	49.8	26.2	0.458		
	25	54.4	27.9	23.4	0.513		
<b>250</b>	100	237.9	158.3	18.0	0.665	23.6	0.508
	75	178.4	96.1	22.3	0.539		
	50	118.9	56.3	25.3	0.473		
	25	59.5	32.0	22.3	0.538		

1. Rated in accordance with ARI Standard 550/590, based on evaporator temperature drop of 10°F, 3 gpm/ton on the condenser, evaporator fouling factor of 0.0001°F·ft<sup>2</sup>·h/Btu and condenser fouling factor of 0.00025°F·ft<sup>2</sup>·h/Btu.
2. Performance is based on 2 pass evaporator configuration.
3. Consult Trane representative for additional performance information.
4. kW input is for compressors only.
5. EER – Energy Efficiency Ratio (Btu/W·h). Power inputs include compressors and control power.

**Table 10. Part Load Performance – 50 Hz – premium efficiency – I-P units**

Unit Size	% Load	Tons	kW	EER	kW/ton	IPLV	
						EER	kW/ton
<b>160</b>	100	169.8	106.0	19.2	0.624	25.4	0.473
	75	127.4	65.5	23.3	0.514		
	50	84.9	36.4	28.0	0.428		
	25	42.5	21.9	23.3	0.517		
<b>180</b>	100	187.1	117.6	19.1	0.629	25.8	0.465
	75	140.3	73.4	22.9	0.523		
	50	93.6	39.1	28.7	0.418		
	25	46.8	22.1	25.4	0.473		
<b>200</b>	100	201.3	129.2	18.7	0.642	24.7	0.486
	75	150.9	81.3	22.3	0.538		
	50	100.6	43.4	27.8	0.432		
	25	50.3	27.3	22.1	0.542		

1. Rated in accordance with ARI Standard 550/590, based on evaporator temperature drop of 10°F, 3 gpm/ton on the condenser, evaporator fouling factor of 0.0001°F·ft<sup>2</sup>·h/Btu and condenser fouling factor of 0.00025°F·ft<sup>2</sup>·h/Btu.
2. Performance is based on 2 pass evaporator configuration.
3. Consult Trane representative for additional performance information.
4. kW input is for compressors only.
5. EER – Energy Efficiency Ratio (Btu/W·h). Power inputs include compressors and control power.



## Performance Data

**Table 11. Performance Data - 50 Hz - standard efficiency - SI units**

Evaporator Leaving Water Temperature (°C)	Unit Size	Condenser Entering Water Temperature (°C)								
		25			30			35		
		kW Cooling	kW input	COP	kW Cooling	kW input	COP	kW Cooling	kW input	COP
5	70	257.1	47.8	5.3	242.4	53.5	4.5	226.9	60.0	3.8
	80	294.9	55.5	5.3	277.7	62.1	4.4	259.4	69.8	3.7
	90	335.2	63.0	5.3	315.6	70.5	4.5	294.5	79.1	3.7
	100	356.5	66.8	5.3	336.1	74.8	4.5	314.5	84.0	3.7
	110	377.9	70.9	5.3	356.8	79.5	4.5	334.5	89.3	3.7
	120	424.5	78.6	5.4	400.6	88.1	4.5	375.3	98.8	3.8
	130	461.1	84.3	5.4	435.5	94.5	4.6	408.4	106.0	3.8
	140	497.4	92.0	5.4	470.5	102.9	4.6	442.2	115.4	3.8
	150	540.6	98.8	5.5	511.9	110.2	4.6	482.1	123.5	3.9
7	70	275.6	48.3	5.7	260.3	54.0	4.8	244.1	60.5	4.0
	80	316.2	56.1	5.6	298.3	62.7	4.7	279.3	70.2	4.0
	90	359.4	63.7	5.6	339.0	71.1	4.7	317.2	79.6	4.0
	100	382.1	67.4	5.6	360.9	75.4	4.8	338.4	84.5	4.0
	110	405.0	71.5	5.6	382.9	80.0	4.8	359.5	89.7	4.0
	120	455.5	79.5	5.7	430.4	88.8	4.8	403.8	99.3	4.0
	130	494.7	85.2	5.8	467.9	95.1	4.9	439.3	106.4	4.1
	140	533.5	93.1	5.7	505.2	103.8	4.8	475.6	116.1	4.1
	150	580.0	100.0	5.8	549.9	111.3	4.9	518.6	124.4	4.2
9	70	294.9	49.0	6.0	278.9	54.6	5.1	262.0	61.0	4.3
	80	338.3	56.8	5.9	319.8	63.3	5.0	300.1	70.8	4.2
	90	384.4	64.5	5.9	363.3	71.8	5.0	340.8	80.2	4.2
	100	408.7	68.2	6.0	386.7	76.0	5.1	363.2	85.0	4.3
	110	433.2	72.2	6.0	410.1	80.6	5.1	385.5	90.2	4.3
	120	487.8	80.4	6.0	461.5	89.6	5.1	433.5	99.9	4.3
	130	529.7	86.1	6.1	501.6	95.8	5.2	471.6	106.9	4.4
	140	571.1	94.3	6.0	541.5	104.8	5.1	510.4	116.9	4.3
	150	621.0	101.4	6.1	589.5	112.6	5.2	556.7	125.6	4.4

1. Rated in accordance with ARI Standard 550/590, based on an evaporator temperature drop of 5.6°C, 0.054 L/s per kW on the condenser, evaporator fouling factor of 0.01761°K·m<sup>2</sup>/kW and condenser fouling of 0.044025°K·m<sup>2</sup>/kW.
2. Performance is based on 2 pass evaporator configuration.
3. Consult Trane representative for additional performance information.
4. kW input is for compressors only.
5. COP—Coefficient of Performance. Power inputs include compressors and control power.
6. Interpolation between points is permissible. Extrapolation is not permitted.

**Table 12. Performance Data - 50 Hz - high efficiency - SI units**

Evaporator Leaving Water Temperature (°C)	Unit Size	Condenser Entering Water Temperature (°C)								
		25			30			35		
		kW Cooling	kW input	COP	kW Cooling	kW input	COP	kW Cooling	kW input	COP
5	<b>60</b>	232.9	39.9	5.8	219.1	44.7	4.9	204.7	50.1	4.1
	<b>70</b>	274.4	47.0	5.8	258.7	52.5	4.9	242.2	58.9	4.1
	<b>80</b>	314.4	54.6	5.7	296.2	61.0	4.8	276.8	68.4	4.0
	<b>90</b>	361.9	62.4	5.8	340.6	69.6	4.9	317.9	77.9	4.1
	<b>100</b>	386.3	65.9	5.8	363.9	73.6	4.9	340.3	82.5	4.1
	<b>110</b>	413.6	69.8	5.9	389.9	78.1	5.0	364.9	87.5	4.1
	<b>120</b>	447.9	76.2	5.8	422.7	85.2	4.9	395.9	95.5	4.1
	<b>130</b>	483.1	82.8	5.8	456.6	92.6	4.9	428.3	103.9	4.1
	<b>140</b>	525.3	89.7	5.8	497.0	100.1	4.9	467.2	112.2	4.2
	<b>160</b>	571.7	96.5	5.9	541.4	107.4	5.0	509.9	120.2	4.2
	<b>180</b>	630.1	107.5	5.8	596.2	120.0	5.0	560.8	134.4	4.2
	<b>200</b>	692.0	117.8	5.9	654.8	131.7	5.0	615.7	147.7	4.2
	<b>220</b>	756.1	131.1	5.8	716.8	145.4	4.9	675.4	161.9	4.2
<b>250</b>	826.0	143.3	5.7	784.3	157.7	5.0	740.7	174.4	4.2	
7	<b>60</b>	250.6	40.3	6.2	236.3	44.9	5.2	221.3	50.2	4.4
	<b>70</b>	294.5	47.6	6.1	278.2	53.0	5.2	260.9	59.3	4.4
	<b>80</b>	337.5	55.3	6.1	318.6	61.6	5.1	298.4	68.9	4.3
	<b>90</b>	388.8	63.1	6.1	366.6	70.2	5.2	343.1	78.4	4.4
	<b>100</b>	415.0	66.6	6.2	391.7	74.2	5.3	367.0	83.0	4.4
	<b>110</b>	444.6	70.5	6.3	419.8	78.6	5.3	393.5	87.9	4.5
	<b>120</b>	481.3	76.9	6.2	454.8	85.7	5.3	426.7	95.9	4.4
	<b>130</b>	518.5	83.5	6.2	490.7	93.2	5.2	461.1	104.1	4.4
	<b>140</b>	563.9	90.6	6.2	534.3	100.9	5.3	503.1	112.7	4.4
	<b>160</b>	614.1	97.6	6.3	582.3	108.4	5.4	549.2	121.0	4.5
	<b>180</b>	676.8	108.7	6.2	641.3	120.9	5.3	604.2	135.1	4.5
	<b>200</b>	742.8	119.0	6.2	704.0	132.6	5.3	663.2	148.3	4.5
	<b>220</b>	810.8	133.0	6.1	769.8	146.9	5.2	726.8	163.1	4.4
<b>250</b>	884.9	145.9	6.0	841.6	159.9	5.2	796.2	176.4	4.5	



## Performance Data

**Table 12. Performance Data - 50 Hz - high efficiency - SI units**

Evaporator Leaving Water Temperature (°C)	Unit Size	Condenser Entering Water Temperature (°C)								
		25			30			35		
		kW Cooling	kW input	COP	kW Cooling	kW input	COP	kW Cooling	kW input	COP
9	<b>60</b>	268.9	40.7	6.5	254.1	45.3	5.6	238.6	50.5	4.7
	<b>70</b>	315.6	48.2	6.5	298.5	53.6	5.5	280.4	59.8	4.7
	<b>80</b>	361.6	56.0	6.4	341.9	62.2	5.5	320.9	69.4	4.6
	<b>90</b>	416.7	64.0	6.5	393.8	70.9	5.5	369.4	79.0	4.7
	<b>100</b>	444.9	67.4	6.6	420.7	74.9	5.6	395.0	83.5	4.7
	<b>110</b>	476.9	71.3	6.7	451.0	79.3	5.7	423.5	88.4	4.8
	<b>120</b>	516.0	77.7	6.6	488.4	86.4	5.6	458.9	96.3	4.7
	<b>130</b>	555.3	84.3	6.6	526.4	93.8	5.6	495.4	104.5	4.7
	<b>140</b>	604.1	91.6	6.6	573.3	101.7	5.6	540.6	113.3	4.8
	<b>160</b>	658.2	98.9	6.6	625.0	109.5	5.7	590.3	121.9	4.8
	<b>180</b>	725.6	110.0	6.6	688.4	122.0	5.6	649.6	135.9	4.8
	<b>200</b>	795.6	120.3	6.6	755.2	133.6	5.6	712.8	149.0	4.8
	<b>220</b>	867.5	135.0	6.4	824.9	148.7	5.5	780.2	164.6	4.7
<b>250</b>	946.2	148.8	6.3	901.1	162.5	5.5	853.9	178.6	4.8	

1. Rated in accordance with ARI Standard 550/590, based on an evaporator temperature drop of 5.6°C, 0.054 L/s per kW on the condenser, evaporator fouling factor of 0.01761°K·m<sup>3</sup>/kW and condenser fouling of 0.044025°K·m<sup>3</sup>/kW.
2. Performance is based on 2 pass evaporator configuration.
3. Consult Trane representative for additional performance information.
4. kW input is for compressors only.
5. COP—Coefficient of Performance. Power inputs include compressors and control power.
6. Interpolation between points is permissible. Extrapolation is not permitted.

**Table 13. Performance Data - 50 Hz- premium efficiency - SI units**

Evaporator Leaving Water Temperature (°C)	Unit Size	Condenser Entering Water Temperature (°C)								
		25			30			35		
		kW Cooling	kW input	COP	kW Cooling	kW input	COP	kW Cooling	kW input	COP
<b>5</b>	<b>160</b>	589.4	95.4	6.2	557.6	106.1	5.2	524.6	118.6	4.4
	<b>180</b>	649.7	105.7	6.1	614.2	117.9	5.2	577.1	132.0	4.4
	<b>200</b>	699.4	116.1	6.0	661.4	129.7	5.1	621.6	145.5	4.3
<b>7</b>	<b>160</b>	634.4	96.6	6.5	600.9	107.1	5.6	566.2	119.4	4.7
	<b>180</b>	699.3	106.9	6.5	662.0	118.8	5.6	623.1	132.6	4.7
	<b>200</b>	751.6	117.2	6.4	712.0	130.5	5.4	670.4	146.0	4.6
<b>9</b>	<b>160</b>	681.5	98.0	6.9	646.4	108.2	6.0	609.8	120.3	5.1
	<b>180</b>	751.3	108.2	6.9	712.1	119.8	5.9	671.3	133.4	5.0
	<b>200</b>	806.1	118.4	6.8	764.7	131.5	5.8	721.3	146.7	4.9

1. Rated in accordance with ARI Standard 550/590, based on an evaporator temperature drop of 5.6°C, 0.054 L/s per kW on the condenser, evaporator fouling factor of 0.01761°K·m<sup>3</sup>/kW and condenser fouling of 0.044025°K·m<sup>3</sup>/kW.
2. Performance is based on 2 pass evaporator configuration.
3. Consult Trane representative for additional performance information.
4. kW input is for compressors only.
5. COP-Coefficient of Performance. Power inputs include compressors and control power.
6. Interpolation between points is permissible. Extrapolation is not permitted.



## Performance Data

**Table 14. Part Load Performance - 50 Hz - standard efficiency - SI units**

Unit Size	% Load	Cooling kW	kW Input	COP	IPLV COP
<b>70</b>	100	258.8	53.6	4.83	6.52
	75	194.1	32.3	6.01	
	50	129.4	18.1	7.15	
	25	64.7	10.5	6.19	
<b>80</b>	100	296.7	62.2	4.77	6.56
	75	222.6	37.8	5.89	
	50	148.4	21	7.07	
	25	74.2	10.5	7.10	
<b>90</b>	100	337.2	70.5	4.78	6.46
	75	252.8	43.1	5.87	
	50	168.8	23.7	7.12	
	25	84.4	13.5	6.23	
<b>100</b>	100	359.0	74.7	4.80	6.51
	75	269.3	45.9	5.86	
	50	179.3	25.2	7.13	
	25	89.7	13.6	6.58	
<b>110</b>	100	380.8	79.3	4.80	6.37
	75	285.5	49.2	5.81	
	50	190.6	27	7.05	
	25	95.3	16.3	5.86	
<b>120</b>	100	427.9	87.9	4.87	6.55
	75	321.0	54.9	5.85	
	50	214.1	29.6	7.23	
	25	106.9	16.3	6.56	
<b>130</b>	100	465.2	94.2	4.94	6.55
	75	349.1	59.3	5.89	
	50	232.8	31.7	7.34	
	25	116.4	19.5	5.95	
<b>140</b>	100	502.4	102.8	4.89	6.54
	75	376.9	64	5.89	
	50	251.0	34.7	7.23	
	25	125.5	19.8	6.34	
<b>150</b>	100	546.7	110.2	4.96	6.54
	75	410.0	68.2	6.01	
	50	273.2	37.9	7.20	
	25	136.8	22.7	6.01	

1. Rated in accordance with ARI Standard 550/590, based on an evaporator temperature drop of 5.6°C, 0.054 L/s per kW on the condenser, evaporator fouling factor of 0.01761°C·m<sup>3</sup>/kW and condenser fouling of 0.044025°C·m<sup>3</sup>/kW.
2. Performance is based on 2 pass evaporator configuration.
3. Consult Trane representative for additional performance information.
4. kW input is for compressors only.
5. COP—Coefficient of Performance. Power inputs include compressors and control power.

**Table 15. Part Load Performance - 50 Hz - high efficiency - SI units**

<b>Unit Size</b>	<b>% Load</b>	<b>Cooling kW</b>	<b>kW Input</b>	<b>COP</b>	<b>IPLV COP</b>
<b>60</b>	100	234.9	44.7	5.26	7.15
	75	176.2	27.3	6.46	
	50	117.4	14.8	7.95	
	25	58.7	8.8	6.67	
<b>70</b>	100	276.7	52.7	5.25	7.10
	75	207.4	31.7	6.54	
	50	138.2	17.8	7.76	
	25	69.3	10.2	6.77	
<b>80</b>	100	316.8	61.1	5.19	7.16
	75	237.7	37.1	6.40	
	50	158.2	20.4	7.78	
	25	79.1	10.3	7.69	
<b>90</b>	100	364.6	69.6	5.23	7.09
	75	273.5	42.4	6.44	
	50	182.1	23.4	7.80	
	25	91.1	13.3	6.84	
<b>100</b>	100	389.6	73.6	5.30	7.20
	75	292.2	45.2	6.46	
	50	194.8	24.5	7.94	
	25	97.4	13.5	7.23	
<b>110</b>	100	417.3	78	5.35	7.10
	75	312.9	48.3	6.49	
	50	208.5	26.5	7.87	
	25	104.4	15.9	6.56	
<b>120</b>	100	452.2	85	5.32	7.12
	75	339.3	53	6.39	
	50	226.1	28.8	7.85	
	25	113.2	16	7.09	
<b>130</b>	100	488.0	92.3	5.29	7.00
	75	366.0	58	6.30	
	50	244.0	31	7.88	
	25	122.0	19.1	6.37	
<b>140</b>	100	531.3	99.9	5.32	7.12
	75	398.4	62.3	6.39	
	50	265.5	33.6	7.92	
	25	132.9	19.3	6.87	
<b>160</b>	100	578.7	107.3	5.39	7.10
	75	433.9	66.4	6.54	
	50	289.4	37	7.81	
	25	144.9	22	6.56	
<b>180</b>	100	637.4	119.7	5.33	7.16
	75	478.2	74.8	6.39	
	50	318.9	40.3	7.90	
	25	159.3	22.2	7.18	



## Performance Data

**Table 15. Part Load Performance - 50 Hz - high efficiency - SI units**

Unit Size	% Load	Cooling kW	kW Input	COP	IPLV COP
<b>200</b>	100	699.7	131.2	5.34	7.05
	75	524.9	82.6	6.36	
	50	349.8	44.2	7.90	
	25	175.1	27.5	6.37	
<b>220</b>	100	765.1	145.4	5.26	7.02
	75	573.8	89.6	6.40	
	50	382.5	49.8	7.68	
	25	191.3	27.9	6.85	
<b>250</b>	100	836.4	158.3	5.29	6.92
	75	627.2	96.1	6.52	
	50	418.0	56.3	7.43	
	25	209.2	32	6.54	

1. Rated in accordance with ARI Standard 550/590, based on an evaporator temperature drop of 5.6°C, 0.054 L/s per kW on the condenser, evaporator fouling factor of 0.01761°K·m<sup>3</sup>/kW and condenser fouling of 0.044025°K·m<sup>3</sup>/kW.
2. Performance is based on 2 pass evaporator configuration.
3. Consult Trane representative for additional performance information.
4. kW input is for compressors only.
5. COP–Coefficient of Performance. Power inputs include compressors and control power.

**Table 16. Part Load Performance - 50 Hz - premium efficiency - SI units**

Unit Size	% Load	Cooling kW	kW Input	COP	IPLV COP
<b>160</b>	100	597.0	106	5.63	7.43
	75	447.9	65.5	6.84	
	50	298.5	36.4	8.21	
	25	149.4	21.9	6.80	
<b>180</b>	100	657.8	117.6	5.59	7.56
	75	493.3	73.4	6.72	
	50	329.1	39.1	8.41	
	25	164.5	22.1	7.43	
<b>200</b>	100	707.8	129.2	5.48	7.23
	75	530.6	81.3	6.54	
	50	353.7	43.4	8.14	
	25	176.9	27.3	6.49	

1. Rated in accordance with ARI Standard 550/590, based on an evaporator temperature drop of 5.6°C, 0.054 L/s per kW on the condenser, evaporator fouling factor of 0.01761°K·m<sup>3</sup>/kW and condenser fouling of 0.044025°K·m<sup>3</sup>/kW.
2. Performance is based on 2 pass evaporator configuration.
3. Consult Trane representative for additional performance information.
4. kW input is for compressors only.
5. COP–Coefficient of Performance. Power inputs include compressors and control power.



# Controls

## LCD Touch-Screen Display with Multi-Language Support

The standard DynaView display provided with the Trane CH530 control panel features an LCD touch-screen, allowing access to all operational inputs and outputs. This display supports many languages including: English, Chinese, Dutch, French, German, Italian, Japanese, Korean, Portuguese, Spanish, and Thai.

### Display Features Include:

- LCD touch-screen with LED backlighting, for scrolling access to input and output operating information
- Single-screen, folder/tab-style display of all available information on individual components (evaporator, condenser, compressor, etc.)
- Manual override indication
- Password entry/lockout system to enable or disable display
- Automatic and immediate stop capabilities for standard or immediate manual shutdown
- Fast, easy access to available chiller data in tabbed format, including:
  - Modes of operation, including normal cooling and ice making
  - Water temperatures and setpoints
  - Loading and limiting status and setpoints
  - Average line current
  - Start/stop differential timers
  - Auto/Manual mode for EXV, slide valve, and head pressure control
  - Pump status and override
  - Chilled water reset settings
  - Optional external setpoints, including:
    - i. Chilled water
    - ii. Current-limit
    - iii. Condenser leaving hot water temperature setpoint
    - iv. Ice building
- Reports, listed on a single tabbed screen for easy access, including:
  - ASHRAE, containing all guideline 3 report information
  - Evaporator
  - Condenser
  - Compressor
- Evaporator, condenser, and compressor reports containing all operational information on individual components, including:
  - Water temperatures
  - Refrigerant pressures, temperatures, and approach
  - Oil pressure
  - Flow switch status
  - EXV position
  - Head pressure control command
  - Compressor starts and run-time

- Line phase percent RLA, amps, and volts
- Alarm and diagnostic information, including:
  - Flashing alarms with touch-screen button of alarm condition
  - Scrollable list of last ten active diagnostics
  - Specific information on applicable diagnostic from list of over one-hundred
  - Automatic or manual resetting diagnostic types

### **LonTalk/Tracer Summit Interface**

LonTalk (LCI-C) or Tracer Summit communications capabilities are available, with communication link via single twisted-pair wiring to factory-installed, tested communication board.

Required features:

- LonTalk/Tracer Summit Interface

Additional options that may be used:

- Ice making
- Chilled water temperature reset - outdoor air

External devices required:

- Trane Tracer system or LonTalk compatible system level interface.

### **Tracer Summit**

Trane's depth of experience in chillers and controls makes us a well-qualified choice for automation of chiller plants using water-cooled Series R chillers. The chiller plant control capabilities of the Trane Tracer Summit™ building automation system are unequalled in the industry. Our chiller plant automation software is fully pre-engineered and tested.

Energy Efficiency

- Sequences starting of chillers to optimize the overall chiller plant energy efficiency
- Individual chillers operate as base, peak, or swing based on capacity and efficiency
- Automatically rotates individual chiller operation to equalize runtime and wear between chillers.
- Evaluates and selects the lowest energy consumption alternative from an overall system perspective.

Regulatory Compliance Documentation

- Gathers information and generates the reports mandated in ASHRAE Guideline 3.

Easy Operation and Maintenance

- Remote monitoring and control
- Displays both current operation conditions and scheduled automated control actions
- Concise reports assist in planning for preventative maintenance and verifying performance
- Alarm notification and diagnostic messages aid in quick and accurate troubleshooting

When integrated with a Tracer Summit building management system the total building operation can be optimized. With this system option, the full breadth of Trane's HVAC and controls experience are applied to offer solutions to many facility issues.

### **LonTalk Chiller Controls**

LonTalk is a communications protocol developed by the Echelon™ Corporation. The LonMark™ association develops control profiles using the LonTalk communication protocol. LonTalk is a unit level communications protocol.

LonTalk Communications Interface for Chillers (LCI-C) provides a generic automation system with the LonMark chiller profile inputs/outputs. In addition to the standard points, Trane provides other commonly used network output variables for greater interoperability with any automation system. The complete reference list of Trane LonTalk points is available on the LonMark web site.

Trane controls or another vendor's system can use the predefined list of points with ease to give the operator a complete picture of how the system is running.

### **Time of Day Scheduling**

Time of day scheduling allows the customer to perform simple chiller scheduling without the need for a building automation system.

This feature allows the user to set 10 events in a 7 day time period. For each event the user can specify an activation time and the days of the week the event is active. Any setpoints available can be specified for each event, such as the leaving chilled water temperature (standard) and the current-limit setpoint (optional if ordered).

Required features:

- Time of day scheduling

Additional options that if ordered may be incorporated into the scheduling:

- External chilled water setpoint
- External current-limit setpoint
- Condenser leaving hot water temperature setpoint
- Ice making initiation

### **Hardwire Points**

Remote devices wired from the control panel are another reliable method of providing auxiliary control to a building automation system. Inputs and outputs can be communicated via a typical 4–20 mA electrical signal, an equivalent 2–10 Vdc signal, or by utilizing contact closures.

Selectable options:

- External chilled water setpoint
- External current-limit setpoint
- Ice making control
- Condenser leaving hot water temperature control
- Chilled water temperature reset
- Condenser pressure output
- Motor current analog output
- Programmable relays - available outputs are: alarm-latching, alarm-auto reset, general alarm, warning, chiller limit mode, compressor running, head pressure relief request, and Tracer control



# Electrical Data

Table 17. Electrical Data - 50 Hz- standard efficiency, standard condenser temperatures

Unit ID	Rated Voltage	# Power Connections	Unit Wiring		Motor Data																																																																																																																																																																																																										
			MCA Ckt 1/Ckt 2	Wire (mm)	RLA Ckt 1/Ckt 2	LRA Y Ckt 1/Ckt 2	LRA X-L Ckt 1/Ckt 2																																																																																																																																																																																																								
RTWD 70	380/50/3	1	111	35	48/48	129/129	427/427																																																																																																																																																																																																								
	380/50/3	2	63/61	16/16				RTWD 70	400/50/3	1	106	35	46/46	129/129	427/427	400/50/3	2	60/58	10/10	RTWD 80	380/50/3	1	130	50	48/63	129/144	427/462	380/50/3	2	63/79	16/16	RTWD 80	400/50/3	1	123	35	46/60	129/144	427/462	400/50/3	2	60/75	10/16	RTWD 90	380/50/3	1	144	50	63/63	144/144	462/462	380/50/3	2	81/79	25/16	RTWD 90	400/50/3	1	137	50	60/60	144/144	462/462	400/50/3	2	77/75	16/16	RTWD 100	380/50/3	1	160	70	63/76	144/180	462/589	380/50/3	2	81/95	25/25	RTWD 100	400/50/3	1	152	50	60/72	144/180	462/589	400/50/3	2	77/90	16/25	RTWD 110	380/50/3	1	173	70	76/76	180/180	589/589	380/50/3	2	97/95	25/25	RTWD 110	400/50/3	1	164	70	72/72	180/180	589/589	400/50/3	2	92/90	25/25	RTWD 120	380/50/3	1	190	70	76/89	180/217	589/668	380/50/3	2	97/112	25/35	RTWD 120	400/50/3	1	180	70	72/85	180/217	589/668	400/50/3	2	92/106	25/35	RTWD 130	380/50/3	1	203	95	89/89	217/217	668/668	380/50/3	2	114/112	35/35	RTWD 130	400/50/3	1	193	70	85/85	217/217	668/668	400/50/3	2	108/106	35/35	RTWD 140	380/50/3	1	222	95	89/104	217/259	668/796	380/50/3	2	114/130	35/50	RTWD 140	400/50/3	1	211	95	85/99	217/259	668/796	400/50/3	2	108/124	35/35	RTWD 150	380/50/3	1	237	95	104/104	259/259	796/796	380/50/3	2	132/130	50/50	RTWD 150	400/50/3	1	225	95	99/99	259/259	796/796
RTWD 70	400/50/3	1	106	35	46/46	129/129	427/427																																																																																																																																																																																																								
	400/50/3	2	60/58	10/10				RTWD 80	380/50/3	1	130	50	48/63	129/144	427/462	380/50/3	2	63/79	16/16	RTWD 80	400/50/3	1	123	35	46/60	129/144	427/462	400/50/3	2	60/75	10/16	RTWD 90	380/50/3	1	144	50	63/63	144/144	462/462	380/50/3	2	81/79	25/16	RTWD 90	400/50/3	1	137	50	60/60	144/144	462/462	400/50/3	2	77/75	16/16	RTWD 100	380/50/3	1	160	70	63/76	144/180	462/589	380/50/3	2	81/95	25/25	RTWD 100	400/50/3	1	152	50	60/72	144/180	462/589	400/50/3	2	77/90	16/25	RTWD 110	380/50/3	1	173	70	76/76	180/180	589/589	380/50/3	2	97/95	25/25	RTWD 110	400/50/3	1	164	70	72/72	180/180	589/589	400/50/3	2	92/90	25/25	RTWD 120	380/50/3	1	190	70	76/89	180/217	589/668	380/50/3	2	97/112	25/35	RTWD 120	400/50/3	1	180	70	72/85	180/217	589/668	400/50/3	2	92/106	25/35	RTWD 130	380/50/3	1	203	95	89/89	217/217	668/668	380/50/3	2	114/112	35/35	RTWD 130	400/50/3	1	193	70	85/85	217/217	668/668	400/50/3	2	108/106	35/35	RTWD 140	380/50/3	1	222	95	89/104	217/259	668/796	380/50/3	2	114/130	35/50	RTWD 140	400/50/3	1	211	95	85/99	217/259	668/796	400/50/3	2	108/124	35/35	RTWD 150	380/50/3	1	237	95	104/104	259/259	796/796	380/50/3	2	132/130	50/50	RTWD 150	400/50/3	1	225	95	99/99	259/259	796/796	400/50/3	2	126/124	35/35								
RTWD 80	380/50/3	1	130	50	48/63	129/144	427/462																																																																																																																																																																																																								
	380/50/3	2	63/79	16/16				RTWD 80	400/50/3	1	123	35	46/60	129/144	427/462	400/50/3	2	60/75	10/16	RTWD 90	380/50/3	1	144	50	63/63	144/144	462/462	380/50/3	2	81/79	25/16	RTWD 90	400/50/3	1	137	50	60/60	144/144	462/462	400/50/3	2	77/75	16/16	RTWD 100	380/50/3	1	160	70	63/76	144/180	462/589	380/50/3	2	81/95	25/25	RTWD 100	400/50/3	1	152	50	60/72	144/180	462/589	400/50/3	2	77/90	16/25	RTWD 110	380/50/3	1	173	70	76/76	180/180	589/589	380/50/3	2	97/95	25/25	RTWD 110	400/50/3	1	164	70	72/72	180/180	589/589	400/50/3	2	92/90	25/25	RTWD 120	380/50/3	1	190	70	76/89	180/217	589/668	380/50/3	2	97/112	25/35	RTWD 120	400/50/3	1	180	70	72/85	180/217	589/668	400/50/3	2	92/106	25/35	RTWD 130	380/50/3	1	203	95	89/89	217/217	668/668	380/50/3	2	114/112	35/35	RTWD 130	400/50/3	1	193	70	85/85	217/217	668/668	400/50/3	2	108/106	35/35	RTWD 140	380/50/3	1	222	95	89/104	217/259	668/796	380/50/3	2	114/130	35/50	RTWD 140	400/50/3	1	211	95	85/99	217/259	668/796	400/50/3	2	108/124	35/35	RTWD 150	380/50/3	1	237	95	104/104	259/259	796/796	380/50/3	2	132/130	50/50	RTWD 150	400/50/3	1	225	95	99/99	259/259	796/796	400/50/3	2	126/124	35/35																				
RTWD 80	400/50/3	1	123	35	46/60	129/144	427/462																																																																																																																																																																																																								
	400/50/3	2	60/75	10/16				RTWD 90	380/50/3	1	144	50	63/63	144/144	462/462	380/50/3	2	81/79	25/16	RTWD 90	400/50/3	1	137	50	60/60	144/144	462/462	400/50/3	2	77/75	16/16	RTWD 100	380/50/3	1	160	70	63/76	144/180	462/589	380/50/3	2	81/95	25/25	RTWD 100	400/50/3	1	152	50	60/72	144/180	462/589	400/50/3	2	77/90	16/25	RTWD 110	380/50/3	1	173	70	76/76	180/180	589/589	380/50/3	2	97/95	25/25	RTWD 110	400/50/3	1	164	70	72/72	180/180	589/589	400/50/3	2	92/90	25/25	RTWD 120	380/50/3	1	190	70	76/89	180/217	589/668	380/50/3	2	97/112	25/35	RTWD 120	400/50/3	1	180	70	72/85	180/217	589/668	400/50/3	2	92/106	25/35	RTWD 130	380/50/3	1	203	95	89/89	217/217	668/668	380/50/3	2	114/112	35/35	RTWD 130	400/50/3	1	193	70	85/85	217/217	668/668	400/50/3	2	108/106	35/35	RTWD 140	380/50/3	1	222	95	89/104	217/259	668/796	380/50/3	2	114/130	35/50	RTWD 140	400/50/3	1	211	95	85/99	217/259	668/796	400/50/3	2	108/124	35/35	RTWD 150	380/50/3	1	237	95	104/104	259/259	796/796	380/50/3	2	132/130	50/50	RTWD 150	400/50/3	1	225	95	99/99	259/259	796/796	400/50/3	2	126/124	35/35																																
RTWD 90	380/50/3	1	144	50	63/63	144/144	462/462																																																																																																																																																																																																								
	380/50/3	2	81/79	25/16				RTWD 90	400/50/3	1	137	50	60/60	144/144	462/462	400/50/3	2	77/75	16/16	RTWD 100	380/50/3	1	160	70	63/76	144/180	462/589	380/50/3	2	81/95	25/25	RTWD 100	400/50/3	1	152	50	60/72	144/180	462/589	400/50/3	2	77/90	16/25	RTWD 110	380/50/3	1	173	70	76/76	180/180	589/589	380/50/3	2	97/95	25/25	RTWD 110	400/50/3	1	164	70	72/72	180/180	589/589	400/50/3	2	92/90	25/25	RTWD 120	380/50/3	1	190	70	76/89	180/217	589/668	380/50/3	2	97/112	25/35	RTWD 120	400/50/3	1	180	70	72/85	180/217	589/668	400/50/3	2	92/106	25/35	RTWD 130	380/50/3	1	203	95	89/89	217/217	668/668	380/50/3	2	114/112	35/35	RTWD 130	400/50/3	1	193	70	85/85	217/217	668/668	400/50/3	2	108/106	35/35	RTWD 140	380/50/3	1	222	95	89/104	217/259	668/796	380/50/3	2	114/130	35/50	RTWD 140	400/50/3	1	211	95	85/99	217/259	668/796	400/50/3	2	108/124	35/35	RTWD 150	380/50/3	1	237	95	104/104	259/259	796/796	380/50/3	2	132/130	50/50	RTWD 150	400/50/3	1	225	95	99/99	259/259	796/796	400/50/3	2	126/124	35/35																																												
RTWD 90	400/50/3	1	137	50	60/60	144/144	462/462																																																																																																																																																																																																								
	400/50/3	2	77/75	16/16				RTWD 100	380/50/3	1	160	70	63/76	144/180	462/589	380/50/3	2	81/95	25/25	RTWD 100	400/50/3	1	152	50	60/72	144/180	462/589	400/50/3	2	77/90	16/25	RTWD 110	380/50/3	1	173	70	76/76	180/180	589/589	380/50/3	2	97/95	25/25	RTWD 110	400/50/3	1	164	70	72/72	180/180	589/589	400/50/3	2	92/90	25/25	RTWD 120	380/50/3	1	190	70	76/89	180/217	589/668	380/50/3	2	97/112	25/35	RTWD 120	400/50/3	1	180	70	72/85	180/217	589/668	400/50/3	2	92/106	25/35	RTWD 130	380/50/3	1	203	95	89/89	217/217	668/668	380/50/3	2	114/112	35/35	RTWD 130	400/50/3	1	193	70	85/85	217/217	668/668	400/50/3	2	108/106	35/35	RTWD 140	380/50/3	1	222	95	89/104	217/259	668/796	380/50/3	2	114/130	35/50	RTWD 140	400/50/3	1	211	95	85/99	217/259	668/796	400/50/3	2	108/124	35/35	RTWD 150	380/50/3	1	237	95	104/104	259/259	796/796	380/50/3	2	132/130	50/50	RTWD 150	400/50/3	1	225	95	99/99	259/259	796/796	400/50/3	2	126/124	35/35																																																								
RTWD 100	380/50/3	1	160	70	63/76	144/180	462/589																																																																																																																																																																																																								
	380/50/3	2	81/95	25/25				RTWD 100	400/50/3	1	152	50	60/72	144/180	462/589	400/50/3	2	77/90	16/25	RTWD 110	380/50/3	1	173	70	76/76	180/180	589/589	380/50/3	2	97/95	25/25	RTWD 110	400/50/3	1	164	70	72/72	180/180	589/589	400/50/3	2	92/90	25/25	RTWD 120	380/50/3	1	190	70	76/89	180/217	589/668	380/50/3	2	97/112	25/35	RTWD 120	400/50/3	1	180	70	72/85	180/217	589/668	400/50/3	2	92/106	25/35	RTWD 130	380/50/3	1	203	95	89/89	217/217	668/668	380/50/3	2	114/112	35/35	RTWD 130	400/50/3	1	193	70	85/85	217/217	668/668	400/50/3	2	108/106	35/35	RTWD 140	380/50/3	1	222	95	89/104	217/259	668/796	380/50/3	2	114/130	35/50	RTWD 140	400/50/3	1	211	95	85/99	217/259	668/796	400/50/3	2	108/124	35/35	RTWD 150	380/50/3	1	237	95	104/104	259/259	796/796	380/50/3	2	132/130	50/50	RTWD 150	400/50/3	1	225	95	99/99	259/259	796/796	400/50/3	2	126/124	35/35																																																																				
RTWD 100	400/50/3	1	152	50	60/72	144/180	462/589																																																																																																																																																																																																								
	400/50/3	2	77/90	16/25				RTWD 110	380/50/3	1	173	70	76/76	180/180	589/589	380/50/3	2	97/95	25/25	RTWD 110	400/50/3	1	164	70	72/72	180/180	589/589	400/50/3	2	92/90	25/25	RTWD 120	380/50/3	1	190	70	76/89	180/217	589/668	380/50/3	2	97/112	25/35	RTWD 120	400/50/3	1	180	70	72/85	180/217	589/668	400/50/3	2	92/106	25/35	RTWD 130	380/50/3	1	203	95	89/89	217/217	668/668	380/50/3	2	114/112	35/35	RTWD 130	400/50/3	1	193	70	85/85	217/217	668/668	400/50/3	2	108/106	35/35	RTWD 140	380/50/3	1	222	95	89/104	217/259	668/796	380/50/3	2	114/130	35/50	RTWD 140	400/50/3	1	211	95	85/99	217/259	668/796	400/50/3	2	108/124	35/35	RTWD 150	380/50/3	1	237	95	104/104	259/259	796/796	380/50/3	2	132/130	50/50	RTWD 150	400/50/3	1	225	95	99/99	259/259	796/796	400/50/3	2	126/124	35/35																																																																																
RTWD 110	380/50/3	1	173	70	76/76	180/180	589/589																																																																																																																																																																																																								
	380/50/3	2	97/95	25/25				RTWD 110	400/50/3	1	164	70	72/72	180/180	589/589	400/50/3	2	92/90	25/25	RTWD 120	380/50/3	1	190	70	76/89	180/217	589/668	380/50/3	2	97/112	25/35	RTWD 120	400/50/3	1	180	70	72/85	180/217	589/668	400/50/3	2	92/106	25/35	RTWD 130	380/50/3	1	203	95	89/89	217/217	668/668	380/50/3	2	114/112	35/35	RTWD 130	400/50/3	1	193	70	85/85	217/217	668/668	400/50/3	2	108/106	35/35	RTWD 140	380/50/3	1	222	95	89/104	217/259	668/796	380/50/3	2	114/130	35/50	RTWD 140	400/50/3	1	211	95	85/99	217/259	668/796	400/50/3	2	108/124	35/35	RTWD 150	380/50/3	1	237	95	104/104	259/259	796/796	380/50/3	2	132/130	50/50	RTWD 150	400/50/3	1	225	95	99/99	259/259	796/796	400/50/3	2	126/124	35/35																																																																																												
RTWD 110	400/50/3	1	164	70	72/72	180/180	589/589																																																																																																																																																																																																								
	400/50/3	2	92/90	25/25				RTWD 120	380/50/3	1	190	70	76/89	180/217	589/668	380/50/3	2	97/112	25/35	RTWD 120	400/50/3	1	180	70	72/85	180/217	589/668	400/50/3	2	92/106	25/35	RTWD 130	380/50/3	1	203	95	89/89	217/217	668/668	380/50/3	2	114/112	35/35	RTWD 130	400/50/3	1	193	70	85/85	217/217	668/668	400/50/3	2	108/106	35/35	RTWD 140	380/50/3	1	222	95	89/104	217/259	668/796	380/50/3	2	114/130	35/50	RTWD 140	400/50/3	1	211	95	85/99	217/259	668/796	400/50/3	2	108/124	35/35	RTWD 150	380/50/3	1	237	95	104/104	259/259	796/796	380/50/3	2	132/130	50/50	RTWD 150	400/50/3	1	225	95	99/99	259/259	796/796	400/50/3	2	126/124	35/35																																																																																																								
RTWD 120	380/50/3	1	190	70	76/89	180/217	589/668																																																																																																																																																																																																								
	380/50/3	2	97/112	25/35				RTWD 120	400/50/3	1	180	70	72/85	180/217	589/668	400/50/3	2	92/106	25/35	RTWD 130	380/50/3	1	203	95	89/89	217/217	668/668	380/50/3	2	114/112	35/35	RTWD 130	400/50/3	1	193	70	85/85	217/217	668/668	400/50/3	2	108/106	35/35	RTWD 140	380/50/3	1	222	95	89/104	217/259	668/796	380/50/3	2	114/130	35/50	RTWD 140	400/50/3	1	211	95	85/99	217/259	668/796	400/50/3	2	108/124	35/35	RTWD 150	380/50/3	1	237	95	104/104	259/259	796/796	380/50/3	2	132/130	50/50	RTWD 150	400/50/3	1	225	95	99/99	259/259	796/796	400/50/3	2	126/124	35/35																																																																																																																				
RTWD 120	400/50/3	1	180	70	72/85	180/217	589/668																																																																																																																																																																																																								
	400/50/3	2	92/106	25/35				RTWD 130	380/50/3	1	203	95	89/89	217/217	668/668	380/50/3	2	114/112	35/35	RTWD 130	400/50/3	1	193	70	85/85	217/217	668/668	400/50/3	2	108/106	35/35	RTWD 140	380/50/3	1	222	95	89/104	217/259	668/796	380/50/3	2	114/130	35/50	RTWD 140	400/50/3	1	211	95	85/99	217/259	668/796	400/50/3	2	108/124	35/35	RTWD 150	380/50/3	1	237	95	104/104	259/259	796/796	380/50/3	2	132/130	50/50	RTWD 150	400/50/3	1	225	95	99/99	259/259	796/796	400/50/3	2	126/124	35/35																																																																																																																																
RTWD 130	380/50/3	1	203	95	89/89	217/217	668/668																																																																																																																																																																																																								
	380/50/3	2	114/112	35/35				RTWD 130	400/50/3	1	193	70	85/85	217/217	668/668	400/50/3	2	108/106	35/35	RTWD 140	380/50/3	1	222	95	89/104	217/259	668/796	380/50/3	2	114/130	35/50	RTWD 140	400/50/3	1	211	95	85/99	217/259	668/796	400/50/3	2	108/124	35/35	RTWD 150	380/50/3	1	237	95	104/104	259/259	796/796	380/50/3	2	132/130	50/50	RTWD 150	400/50/3	1	225	95	99/99	259/259	796/796	400/50/3	2	126/124	35/35																																																																																																																																												
RTWD 130	400/50/3	1	193	70	85/85	217/217	668/668																																																																																																																																																																																																								
	400/50/3	2	108/106	35/35				RTWD 140	380/50/3	1	222	95	89/104	217/259	668/796	380/50/3	2	114/130	35/50	RTWD 140	400/50/3	1	211	95	85/99	217/259	668/796	400/50/3	2	108/124	35/35	RTWD 150	380/50/3	1	237	95	104/104	259/259	796/796	380/50/3	2	132/130	50/50	RTWD 150	400/50/3	1	225	95	99/99	259/259	796/796	400/50/3	2	126/124	35/35																																																																																																																																																								
RTWD 140	380/50/3	1	222	95	89/104	217/259	668/796																																																																																																																																																																																																								
	380/50/3	2	114/130	35/50				RTWD 140	400/50/3	1	211	95	85/99	217/259	668/796	400/50/3	2	108/124	35/35	RTWD 150	380/50/3	1	237	95	104/104	259/259	796/796	380/50/3	2	132/130	50/50	RTWD 150	400/50/3	1	225	95	99/99	259/259	796/796	400/50/3	2	126/124	35/35																																																																																																																																																																				
RTWD 140	400/50/3	1	211	95	85/99	217/259	668/796																																																																																																																																																																																																								
	400/50/3	2	108/124	35/35				RTWD 150	380/50/3	1	237	95	104/104	259/259	796/796	380/50/3	2	132/130	50/50	RTWD 150	400/50/3	1	225	95	99/99	259/259	796/796	400/50/3	2	126/124	35/35																																																																																																																																																																																
RTWD 150	380/50/3	1	237	95	104/104	259/259	796/796																																																																																																																																																																																																								
	380/50/3	2	132/130	50/50				RTWD 150	400/50/3	1	225	95	99/99	259/259	796/796	400/50/3	2	126/124	35/35																																																																																																																																																																																												
RTWD 150	400/50/3	1	225	95	99/99	259/259	796/796																																																																																																																																																																																																								
	400/50/3	2	126/124	35/35																																																																																																																																																																																																											

1. MCA-Minimum Circuit Ampacity
2. RLA-Rated Load Amps.
3. LRA-Locked Rotor Amps - Based on full winding starts.
4. LRA WD-Locked Rotor Amps in Wye configuration. LRA XL-Locked Rotor Amps in the Delta configuration.
5. Local codes may take precedence.
6. Data containing information on two circuits shown as follows: circuit 1/circuit 2.
7. Standard condensing temperature option refers to entering condenser water temperatures 95°F (35°C) and below.

**Table 18. Electrical Data - 50 Hz - high efficiency, standard condenser temperatures**

Unit ID	Rated Voltage	# Power Conns	Unit Wiring		Motor Data																																																																																																																																																																																																																																														
			MCA Ckt 1/Ckt 2	Wire (mm)	RLA Ckt 1/Ckt 2	LRA Y Ckt 1/Ckt 2	LRA X-L Ckt 1/Ckt 2																																																																																																																																																																																																																																												
<b>RTWD 60</b>	380/50/3	1	92	25	40/40	112/112	370/370																																																																																																																																																																																																																																												
	380/50/3	2	52/50	10/10				<b>RTWD 60</b>	400/50/3	1	88	25	38/38	112/112	370/370	400/50/3	2	50/48	10/10	<b>RTWD 70</b>	380/50/3	1	109	35	47/47	129/129	427/427	380/50/3	2	61/59	16/10	<b>RTWD 70</b>	400/50/3	1	103	35	45/45	129/129	427/427	400/50/3	2	58/56	10/10	<b>RTWD 80</b>	380/50/3	1	127	50	47/62	129/144	427/462	380/50/3	2	61/78	16/16	<b>RTWD 80</b>	400/50/3	1	121	35	45/59	129/144	427/462	400/50/3	2	58/74	10/16	<b>RTWD 90</b>	380/50/3	1	142	50	62/62	144/144	462/462	380/50/3	2	80/78	16/16	<b>RTWD 90</b>	400/50/3	1	135	50	59/59	144/144	462/462	400/50/3	2	76/74	16/16	<b>RTWD 100</b>	380/50/3	1	158	70	62/75	144/180	462/589	380/50/3	2	80/93	16/25	<b>RTWD 100</b>	400/50/3	1	150	50	59/71	144/180	462/589	400/50/3	2	76/89	16/25	<b>RTWD 110</b>	380/50/3	1	170	70	75/75	180/180	589/589	380/50/3	2	96/93	25/25	<b>RTWD 110</b>	400/50/3	1	162	70	71/71	180/180	589/589	400/50/3	2	91/89	25/25	<b>RTWD 120</b>	380/50/3	1	187	70	75/88	180/217	589/668	380/50/3	2	96/111	25/35	<b>RTWD 120</b>	400/50/3	1	178	70	71/84	180/217	589/668	400/50/3	2	91/105	25/35	<b>RTWD 130</b>	380/50/3	1	202	70	88/88	217/217	668/668	380/50/3	2	113/111	35/35	<b>RTWD 130</b>	400/50/3	1	192	70	84/84	217/217	668/668	400/50/3	2	108/105	35/25	<b>RTWD 140</b>	380/50/3	1	220	95	88/103	217/259	668/796	380/50/3	2	113/129	35/35	<b>RTWD 140</b>	400/50/3	1	209	95	84/98	217/259	668/796	400/50/3	2	108/123	35/35	<b>RTWD 160</b>	380/50/3	1	235	95	103/103	259/259	796/796	380/50/3	2	132/129	35/35	<b>RTWD 160</b>	400/50/3	1	223	95	98/98	259/259	796/796	400/50/3	2	125/123	35/35	<b>RTWD 180</b>	380/50/3	1	260	120	103/123	259/291	796/896
<b>RTWD 60</b>	400/50/3	1	88	25	38/38	112/112	370/370																																																																																																																																																																																																																																												
	400/50/3	2	50/48	10/10				<b>RTWD 70</b>	380/50/3	1	109	35	47/47	129/129	427/427	380/50/3	2	61/59	16/10	<b>RTWD 70</b>	400/50/3	1	103	35	45/45	129/129	427/427	400/50/3	2	58/56	10/10	<b>RTWD 80</b>	380/50/3	1	127	50	47/62	129/144	427/462	380/50/3	2	61/78	16/16	<b>RTWD 80</b>	400/50/3	1	121	35	45/59	129/144	427/462	400/50/3	2	58/74	10/16	<b>RTWD 90</b>	380/50/3	1	142	50	62/62	144/144	462/462	380/50/3	2	80/78	16/16	<b>RTWD 90</b>	400/50/3	1	135	50	59/59	144/144	462/462	400/50/3	2	76/74	16/16	<b>RTWD 100</b>	380/50/3	1	158	70	62/75	144/180	462/589	380/50/3	2	80/93	16/25	<b>RTWD 100</b>	400/50/3	1	150	50	59/71	144/180	462/589	400/50/3	2	76/89	16/25	<b>RTWD 110</b>	380/50/3	1	170	70	75/75	180/180	589/589	380/50/3	2	96/93	25/25	<b>RTWD 110</b>	400/50/3	1	162	70	71/71	180/180	589/589	400/50/3	2	91/89	25/25	<b>RTWD 120</b>	380/50/3	1	187	70	75/88	180/217	589/668	380/50/3	2	96/111	25/35	<b>RTWD 120</b>	400/50/3	1	178	70	71/84	180/217	589/668	400/50/3	2	91/105	25/35	<b>RTWD 130</b>	380/50/3	1	202	70	88/88	217/217	668/668	380/50/3	2	113/111	35/35	<b>RTWD 130</b>	400/50/3	1	192	70	84/84	217/217	668/668	400/50/3	2	108/105	35/25	<b>RTWD 140</b>	380/50/3	1	220	95	88/103	217/259	668/796	380/50/3	2	113/129	35/35	<b>RTWD 140</b>	400/50/3	1	209	95	84/98	217/259	668/796	400/50/3	2	108/123	35/35	<b>RTWD 160</b>	380/50/3	1	235	95	103/103	259/259	796/796	380/50/3	2	132/129	35/35	<b>RTWD 160</b>	400/50/3	1	223	95	98/98	259/259	796/796	400/50/3	2	125/123	35/35	<b>RTWD 180</b>	380/50/3	1	260	120	103/123	259/291	796/896	380/50/3	2	132/154	35/50								
<b>RTWD 70</b>	380/50/3	1	109	35	47/47	129/129	427/427																																																																																																																																																																																																																																												
	380/50/3	2	61/59	16/10				<b>RTWD 70</b>	400/50/3	1	103	35	45/45	129/129	427/427	400/50/3	2	58/56	10/10	<b>RTWD 80</b>	380/50/3	1	127	50	47/62	129/144	427/462	380/50/3	2	61/78	16/16	<b>RTWD 80</b>	400/50/3	1	121	35	45/59	129/144	427/462	400/50/3	2	58/74	10/16	<b>RTWD 90</b>	380/50/3	1	142	50	62/62	144/144	462/462	380/50/3	2	80/78	16/16	<b>RTWD 90</b>	400/50/3	1	135	50	59/59	144/144	462/462	400/50/3	2	76/74	16/16	<b>RTWD 100</b>	380/50/3	1	158	70	62/75	144/180	462/589	380/50/3	2	80/93	16/25	<b>RTWD 100</b>	400/50/3	1	150	50	59/71	144/180	462/589	400/50/3	2	76/89	16/25	<b>RTWD 110</b>	380/50/3	1	170	70	75/75	180/180	589/589	380/50/3	2	96/93	25/25	<b>RTWD 110</b>	400/50/3	1	162	70	71/71	180/180	589/589	400/50/3	2	91/89	25/25	<b>RTWD 120</b>	380/50/3	1	187	70	75/88	180/217	589/668	380/50/3	2	96/111	25/35	<b>RTWD 120</b>	400/50/3	1	178	70	71/84	180/217	589/668	400/50/3	2	91/105	25/35	<b>RTWD 130</b>	380/50/3	1	202	70	88/88	217/217	668/668	380/50/3	2	113/111	35/35	<b>RTWD 130</b>	400/50/3	1	192	70	84/84	217/217	668/668	400/50/3	2	108/105	35/25	<b>RTWD 140</b>	380/50/3	1	220	95	88/103	217/259	668/796	380/50/3	2	113/129	35/35	<b>RTWD 140</b>	400/50/3	1	209	95	84/98	217/259	668/796	400/50/3	2	108/123	35/35	<b>RTWD 160</b>	380/50/3	1	235	95	103/103	259/259	796/796	380/50/3	2	132/129	35/35	<b>RTWD 160</b>	400/50/3	1	223	95	98/98	259/259	796/796	400/50/3	2	125/123	35/35	<b>RTWD 180</b>	380/50/3	1	260	120	103/123	259/291	796/896	380/50/3	2	132/154	35/50																				
<b>RTWD 70</b>	400/50/3	1	103	35	45/45	129/129	427/427																																																																																																																																																																																																																																												
	400/50/3	2	58/56	10/10				<b>RTWD 80</b>	380/50/3	1	127	50	47/62	129/144	427/462	380/50/3	2	61/78	16/16	<b>RTWD 80</b>	400/50/3	1	121	35	45/59	129/144	427/462	400/50/3	2	58/74	10/16	<b>RTWD 90</b>	380/50/3	1	142	50	62/62	144/144	462/462	380/50/3	2	80/78	16/16	<b>RTWD 90</b>	400/50/3	1	135	50	59/59	144/144	462/462	400/50/3	2	76/74	16/16	<b>RTWD 100</b>	380/50/3	1	158	70	62/75	144/180	462/589	380/50/3	2	80/93	16/25	<b>RTWD 100</b>	400/50/3	1	150	50	59/71	144/180	462/589	400/50/3	2	76/89	16/25	<b>RTWD 110</b>	380/50/3	1	170	70	75/75	180/180	589/589	380/50/3	2	96/93	25/25	<b>RTWD 110</b>	400/50/3	1	162	70	71/71	180/180	589/589	400/50/3	2	91/89	25/25	<b>RTWD 120</b>	380/50/3	1	187	70	75/88	180/217	589/668	380/50/3	2	96/111	25/35	<b>RTWD 120</b>	400/50/3	1	178	70	71/84	180/217	589/668	400/50/3	2	91/105	25/35	<b>RTWD 130</b>	380/50/3	1	202	70	88/88	217/217	668/668	380/50/3	2	113/111	35/35	<b>RTWD 130</b>	400/50/3	1	192	70	84/84	217/217	668/668	400/50/3	2	108/105	35/25	<b>RTWD 140</b>	380/50/3	1	220	95	88/103	217/259	668/796	380/50/3	2	113/129	35/35	<b>RTWD 140</b>	400/50/3	1	209	95	84/98	217/259	668/796	400/50/3	2	108/123	35/35	<b>RTWD 160</b>	380/50/3	1	235	95	103/103	259/259	796/796	380/50/3	2	132/129	35/35	<b>RTWD 160</b>	400/50/3	1	223	95	98/98	259/259	796/796	400/50/3	2	125/123	35/35	<b>RTWD 180</b>	380/50/3	1	260	120	103/123	259/291	796/896	380/50/3	2	132/154	35/50																																
<b>RTWD 80</b>	380/50/3	1	127	50	47/62	129/144	427/462																																																																																																																																																																																																																																												
	380/50/3	2	61/78	16/16				<b>RTWD 80</b>	400/50/3	1	121	35	45/59	129/144	427/462	400/50/3	2	58/74	10/16	<b>RTWD 90</b>	380/50/3	1	142	50	62/62	144/144	462/462	380/50/3	2	80/78	16/16	<b>RTWD 90</b>	400/50/3	1	135	50	59/59	144/144	462/462	400/50/3	2	76/74	16/16	<b>RTWD 100</b>	380/50/3	1	158	70	62/75	144/180	462/589	380/50/3	2	80/93	16/25	<b>RTWD 100</b>	400/50/3	1	150	50	59/71	144/180	462/589	400/50/3	2	76/89	16/25	<b>RTWD 110</b>	380/50/3	1	170	70	75/75	180/180	589/589	380/50/3	2	96/93	25/25	<b>RTWD 110</b>	400/50/3	1	162	70	71/71	180/180	589/589	400/50/3	2	91/89	25/25	<b>RTWD 120</b>	380/50/3	1	187	70	75/88	180/217	589/668	380/50/3	2	96/111	25/35	<b>RTWD 120</b>	400/50/3	1	178	70	71/84	180/217	589/668	400/50/3	2	91/105	25/35	<b>RTWD 130</b>	380/50/3	1	202	70	88/88	217/217	668/668	380/50/3	2	113/111	35/35	<b>RTWD 130</b>	400/50/3	1	192	70	84/84	217/217	668/668	400/50/3	2	108/105	35/25	<b>RTWD 140</b>	380/50/3	1	220	95	88/103	217/259	668/796	380/50/3	2	113/129	35/35	<b>RTWD 140</b>	400/50/3	1	209	95	84/98	217/259	668/796	400/50/3	2	108/123	35/35	<b>RTWD 160</b>	380/50/3	1	235	95	103/103	259/259	796/796	380/50/3	2	132/129	35/35	<b>RTWD 160</b>	400/50/3	1	223	95	98/98	259/259	796/796	400/50/3	2	125/123	35/35	<b>RTWD 180</b>	380/50/3	1	260	120	103/123	259/291	796/896	380/50/3	2	132/154	35/50																																												
<b>RTWD 80</b>	400/50/3	1	121	35	45/59	129/144	427/462																																																																																																																																																																																																																																												
	400/50/3	2	58/74	10/16				<b>RTWD 90</b>	380/50/3	1	142	50	62/62	144/144	462/462	380/50/3	2	80/78	16/16	<b>RTWD 90</b>	400/50/3	1	135	50	59/59	144/144	462/462	400/50/3	2	76/74	16/16	<b>RTWD 100</b>	380/50/3	1	158	70	62/75	144/180	462/589	380/50/3	2	80/93	16/25	<b>RTWD 100</b>	400/50/3	1	150	50	59/71	144/180	462/589	400/50/3	2	76/89	16/25	<b>RTWD 110</b>	380/50/3	1	170	70	75/75	180/180	589/589	380/50/3	2	96/93	25/25	<b>RTWD 110</b>	400/50/3	1	162	70	71/71	180/180	589/589	400/50/3	2	91/89	25/25	<b>RTWD 120</b>	380/50/3	1	187	70	75/88	180/217	589/668	380/50/3	2	96/111	25/35	<b>RTWD 120</b>	400/50/3	1	178	70	71/84	180/217	589/668	400/50/3	2	91/105	25/35	<b>RTWD 130</b>	380/50/3	1	202	70	88/88	217/217	668/668	380/50/3	2	113/111	35/35	<b>RTWD 130</b>	400/50/3	1	192	70	84/84	217/217	668/668	400/50/3	2	108/105	35/25	<b>RTWD 140</b>	380/50/3	1	220	95	88/103	217/259	668/796	380/50/3	2	113/129	35/35	<b>RTWD 140</b>	400/50/3	1	209	95	84/98	217/259	668/796	400/50/3	2	108/123	35/35	<b>RTWD 160</b>	380/50/3	1	235	95	103/103	259/259	796/796	380/50/3	2	132/129	35/35	<b>RTWD 160</b>	400/50/3	1	223	95	98/98	259/259	796/796	400/50/3	2	125/123	35/35	<b>RTWD 180</b>	380/50/3	1	260	120	103/123	259/291	796/896	380/50/3	2	132/154	35/50																																																								
<b>RTWD 90</b>	380/50/3	1	142	50	62/62	144/144	462/462																																																																																																																																																																																																																																												
	380/50/3	2	80/78	16/16				<b>RTWD 90</b>	400/50/3	1	135	50	59/59	144/144	462/462	400/50/3	2	76/74	16/16	<b>RTWD 100</b>	380/50/3	1	158	70	62/75	144/180	462/589	380/50/3	2	80/93	16/25	<b>RTWD 100</b>	400/50/3	1	150	50	59/71	144/180	462/589	400/50/3	2	76/89	16/25	<b>RTWD 110</b>	380/50/3	1	170	70	75/75	180/180	589/589	380/50/3	2	96/93	25/25	<b>RTWD 110</b>	400/50/3	1	162	70	71/71	180/180	589/589	400/50/3	2	91/89	25/25	<b>RTWD 120</b>	380/50/3	1	187	70	75/88	180/217	589/668	380/50/3	2	96/111	25/35	<b>RTWD 120</b>	400/50/3	1	178	70	71/84	180/217	589/668	400/50/3	2	91/105	25/35	<b>RTWD 130</b>	380/50/3	1	202	70	88/88	217/217	668/668	380/50/3	2	113/111	35/35	<b>RTWD 130</b>	400/50/3	1	192	70	84/84	217/217	668/668	400/50/3	2	108/105	35/25	<b>RTWD 140</b>	380/50/3	1	220	95	88/103	217/259	668/796	380/50/3	2	113/129	35/35	<b>RTWD 140</b>	400/50/3	1	209	95	84/98	217/259	668/796	400/50/3	2	108/123	35/35	<b>RTWD 160</b>	380/50/3	1	235	95	103/103	259/259	796/796	380/50/3	2	132/129	35/35	<b>RTWD 160</b>	400/50/3	1	223	95	98/98	259/259	796/796	400/50/3	2	125/123	35/35	<b>RTWD 180</b>	380/50/3	1	260	120	103/123	259/291	796/896	380/50/3	2	132/154	35/50																																																																				
<b>RTWD 90</b>	400/50/3	1	135	50	59/59	144/144	462/462																																																																																																																																																																																																																																												
	400/50/3	2	76/74	16/16				<b>RTWD 100</b>	380/50/3	1	158	70	62/75	144/180	462/589	380/50/3	2	80/93	16/25	<b>RTWD 100</b>	400/50/3	1	150	50	59/71	144/180	462/589	400/50/3	2	76/89	16/25	<b>RTWD 110</b>	380/50/3	1	170	70	75/75	180/180	589/589	380/50/3	2	96/93	25/25	<b>RTWD 110</b>	400/50/3	1	162	70	71/71	180/180	589/589	400/50/3	2	91/89	25/25	<b>RTWD 120</b>	380/50/3	1	187	70	75/88	180/217	589/668	380/50/3	2	96/111	25/35	<b>RTWD 120</b>	400/50/3	1	178	70	71/84	180/217	589/668	400/50/3	2	91/105	25/35	<b>RTWD 130</b>	380/50/3	1	202	70	88/88	217/217	668/668	380/50/3	2	113/111	35/35	<b>RTWD 130</b>	400/50/3	1	192	70	84/84	217/217	668/668	400/50/3	2	108/105	35/25	<b>RTWD 140</b>	380/50/3	1	220	95	88/103	217/259	668/796	380/50/3	2	113/129	35/35	<b>RTWD 140</b>	400/50/3	1	209	95	84/98	217/259	668/796	400/50/3	2	108/123	35/35	<b>RTWD 160</b>	380/50/3	1	235	95	103/103	259/259	796/796	380/50/3	2	132/129	35/35	<b>RTWD 160</b>	400/50/3	1	223	95	98/98	259/259	796/796	400/50/3	2	125/123	35/35	<b>RTWD 180</b>	380/50/3	1	260	120	103/123	259/291	796/896	380/50/3	2	132/154	35/50																																																																																
<b>RTWD 100</b>	380/50/3	1	158	70	62/75	144/180	462/589																																																																																																																																																																																																																																												
	380/50/3	2	80/93	16/25				<b>RTWD 100</b>	400/50/3	1	150	50	59/71	144/180	462/589	400/50/3	2	76/89	16/25	<b>RTWD 110</b>	380/50/3	1	170	70	75/75	180/180	589/589	380/50/3	2	96/93	25/25	<b>RTWD 110</b>	400/50/3	1	162	70	71/71	180/180	589/589	400/50/3	2	91/89	25/25	<b>RTWD 120</b>	380/50/3	1	187	70	75/88	180/217	589/668	380/50/3	2	96/111	25/35	<b>RTWD 120</b>	400/50/3	1	178	70	71/84	180/217	589/668	400/50/3	2	91/105	25/35	<b>RTWD 130</b>	380/50/3	1	202	70	88/88	217/217	668/668	380/50/3	2	113/111	35/35	<b>RTWD 130</b>	400/50/3	1	192	70	84/84	217/217	668/668	400/50/3	2	108/105	35/25	<b>RTWD 140</b>	380/50/3	1	220	95	88/103	217/259	668/796	380/50/3	2	113/129	35/35	<b>RTWD 140</b>	400/50/3	1	209	95	84/98	217/259	668/796	400/50/3	2	108/123	35/35	<b>RTWD 160</b>	380/50/3	1	235	95	103/103	259/259	796/796	380/50/3	2	132/129	35/35	<b>RTWD 160</b>	400/50/3	1	223	95	98/98	259/259	796/796	400/50/3	2	125/123	35/35	<b>RTWD 180</b>	380/50/3	1	260	120	103/123	259/291	796/896	380/50/3	2	132/154	35/50																																																																																												
<b>RTWD 100</b>	400/50/3	1	150	50	59/71	144/180	462/589																																																																																																																																																																																																																																												
	400/50/3	2	76/89	16/25				<b>RTWD 110</b>	380/50/3	1	170	70	75/75	180/180	589/589	380/50/3	2	96/93	25/25	<b>RTWD 110</b>	400/50/3	1	162	70	71/71	180/180	589/589	400/50/3	2	91/89	25/25	<b>RTWD 120</b>	380/50/3	1	187	70	75/88	180/217	589/668	380/50/3	2	96/111	25/35	<b>RTWD 120</b>	400/50/3	1	178	70	71/84	180/217	589/668	400/50/3	2	91/105	25/35	<b>RTWD 130</b>	380/50/3	1	202	70	88/88	217/217	668/668	380/50/3	2	113/111	35/35	<b>RTWD 130</b>	400/50/3	1	192	70	84/84	217/217	668/668	400/50/3	2	108/105	35/25	<b>RTWD 140</b>	380/50/3	1	220	95	88/103	217/259	668/796	380/50/3	2	113/129	35/35	<b>RTWD 140</b>	400/50/3	1	209	95	84/98	217/259	668/796	400/50/3	2	108/123	35/35	<b>RTWD 160</b>	380/50/3	1	235	95	103/103	259/259	796/796	380/50/3	2	132/129	35/35	<b>RTWD 160</b>	400/50/3	1	223	95	98/98	259/259	796/796	400/50/3	2	125/123	35/35	<b>RTWD 180</b>	380/50/3	1	260	120	103/123	259/291	796/896	380/50/3	2	132/154	35/50																																																																																																								
<b>RTWD 110</b>	380/50/3	1	170	70	75/75	180/180	589/589																																																																																																																																																																																																																																												
	380/50/3	2	96/93	25/25				<b>RTWD 110</b>	400/50/3	1	162	70	71/71	180/180	589/589	400/50/3	2	91/89	25/25	<b>RTWD 120</b>	380/50/3	1	187	70	75/88	180/217	589/668	380/50/3	2	96/111	25/35	<b>RTWD 120</b>	400/50/3	1	178	70	71/84	180/217	589/668	400/50/3	2	91/105	25/35	<b>RTWD 130</b>	380/50/3	1	202	70	88/88	217/217	668/668	380/50/3	2	113/111	35/35	<b>RTWD 130</b>	400/50/3	1	192	70	84/84	217/217	668/668	400/50/3	2	108/105	35/25	<b>RTWD 140</b>	380/50/3	1	220	95	88/103	217/259	668/796	380/50/3	2	113/129	35/35	<b>RTWD 140</b>	400/50/3	1	209	95	84/98	217/259	668/796	400/50/3	2	108/123	35/35	<b>RTWD 160</b>	380/50/3	1	235	95	103/103	259/259	796/796	380/50/3	2	132/129	35/35	<b>RTWD 160</b>	400/50/3	1	223	95	98/98	259/259	796/796	400/50/3	2	125/123	35/35	<b>RTWD 180</b>	380/50/3	1	260	120	103/123	259/291	796/896	380/50/3	2	132/154	35/50																																																																																																																				
<b>RTWD 110</b>	400/50/3	1	162	70	71/71	180/180	589/589																																																																																																																																																																																																																																												
	400/50/3	2	91/89	25/25				<b>RTWD 120</b>	380/50/3	1	187	70	75/88	180/217	589/668	380/50/3	2	96/111	25/35	<b>RTWD 120</b>	400/50/3	1	178	70	71/84	180/217	589/668	400/50/3	2	91/105	25/35	<b>RTWD 130</b>	380/50/3	1	202	70	88/88	217/217	668/668	380/50/3	2	113/111	35/35	<b>RTWD 130</b>	400/50/3	1	192	70	84/84	217/217	668/668	400/50/3	2	108/105	35/25	<b>RTWD 140</b>	380/50/3	1	220	95	88/103	217/259	668/796	380/50/3	2	113/129	35/35	<b>RTWD 140</b>	400/50/3	1	209	95	84/98	217/259	668/796	400/50/3	2	108/123	35/35	<b>RTWD 160</b>	380/50/3	1	235	95	103/103	259/259	796/796	380/50/3	2	132/129	35/35	<b>RTWD 160</b>	400/50/3	1	223	95	98/98	259/259	796/796	400/50/3	2	125/123	35/35	<b>RTWD 180</b>	380/50/3	1	260	120	103/123	259/291	796/896	380/50/3	2	132/154	35/50																																																																																																																																
<b>RTWD 120</b>	380/50/3	1	187	70	75/88	180/217	589/668																																																																																																																																																																																																																																												
	380/50/3	2	96/111	25/35				<b>RTWD 120</b>	400/50/3	1	178	70	71/84	180/217	589/668	400/50/3	2	91/105	25/35	<b>RTWD 130</b>	380/50/3	1	202	70	88/88	217/217	668/668	380/50/3	2	113/111	35/35	<b>RTWD 130</b>	400/50/3	1	192	70	84/84	217/217	668/668	400/50/3	2	108/105	35/25	<b>RTWD 140</b>	380/50/3	1	220	95	88/103	217/259	668/796	380/50/3	2	113/129	35/35	<b>RTWD 140</b>	400/50/3	1	209	95	84/98	217/259	668/796	400/50/3	2	108/123	35/35	<b>RTWD 160</b>	380/50/3	1	235	95	103/103	259/259	796/796	380/50/3	2	132/129	35/35	<b>RTWD 160</b>	400/50/3	1	223	95	98/98	259/259	796/796	400/50/3	2	125/123	35/35	<b>RTWD 180</b>	380/50/3	1	260	120	103/123	259/291	796/896	380/50/3	2	132/154	35/50																																																																																																																																												
<b>RTWD 120</b>	400/50/3	1	178	70	71/84	180/217	589/668																																																																																																																																																																																																																																												
	400/50/3	2	91/105	25/35				<b>RTWD 130</b>	380/50/3	1	202	70	88/88	217/217	668/668	380/50/3	2	113/111	35/35	<b>RTWD 130</b>	400/50/3	1	192	70	84/84	217/217	668/668	400/50/3	2	108/105	35/25	<b>RTWD 140</b>	380/50/3	1	220	95	88/103	217/259	668/796	380/50/3	2	113/129	35/35	<b>RTWD 140</b>	400/50/3	1	209	95	84/98	217/259	668/796	400/50/3	2	108/123	35/35	<b>RTWD 160</b>	380/50/3	1	235	95	103/103	259/259	796/796	380/50/3	2	132/129	35/35	<b>RTWD 160</b>	400/50/3	1	223	95	98/98	259/259	796/796	400/50/3	2	125/123	35/35	<b>RTWD 180</b>	380/50/3	1	260	120	103/123	259/291	796/896	380/50/3	2	132/154	35/50																																																																																																																																																								
<b>RTWD 130</b>	380/50/3	1	202	70	88/88	217/217	668/668																																																																																																																																																																																																																																												
	380/50/3	2	113/111	35/35				<b>RTWD 130</b>	400/50/3	1	192	70	84/84	217/217	668/668	400/50/3	2	108/105	35/25	<b>RTWD 140</b>	380/50/3	1	220	95	88/103	217/259	668/796	380/50/3	2	113/129	35/35	<b>RTWD 140</b>	400/50/3	1	209	95	84/98	217/259	668/796	400/50/3	2	108/123	35/35	<b>RTWD 160</b>	380/50/3	1	235	95	103/103	259/259	796/796	380/50/3	2	132/129	35/35	<b>RTWD 160</b>	400/50/3	1	223	95	98/98	259/259	796/796	400/50/3	2	125/123	35/35	<b>RTWD 180</b>	380/50/3	1	260	120	103/123	259/291	796/896	380/50/3	2	132/154	35/50																																																																																																																																																																				
<b>RTWD 130</b>	400/50/3	1	192	70	84/84	217/217	668/668																																																																																																																																																																																																																																												
	400/50/3	2	108/105	35/25				<b>RTWD 140</b>	380/50/3	1	220	95	88/103	217/259	668/796	380/50/3	2	113/129	35/35	<b>RTWD 140</b>	400/50/3	1	209	95	84/98	217/259	668/796	400/50/3	2	108/123	35/35	<b>RTWD 160</b>	380/50/3	1	235	95	103/103	259/259	796/796	380/50/3	2	132/129	35/35	<b>RTWD 160</b>	400/50/3	1	223	95	98/98	259/259	796/796	400/50/3	2	125/123	35/35	<b>RTWD 180</b>	380/50/3	1	260	120	103/123	259/291	796/896	380/50/3	2	132/154	35/50																																																																																																																																																																																
<b>RTWD 140</b>	380/50/3	1	220	95	88/103	217/259	668/796																																																																																																																																																																																																																																												
	380/50/3	2	113/129	35/35				<b>RTWD 140</b>	400/50/3	1	209	95	84/98	217/259	668/796	400/50/3	2	108/123	35/35	<b>RTWD 160</b>	380/50/3	1	235	95	103/103	259/259	796/796	380/50/3	2	132/129	35/35	<b>RTWD 160</b>	400/50/3	1	223	95	98/98	259/259	796/796	400/50/3	2	125/123	35/35	<b>RTWD 180</b>	380/50/3	1	260	120	103/123	259/291	796/896	380/50/3	2	132/154	35/50																																																																																																																																																																																												
<b>RTWD 140</b>	400/50/3	1	209	95	84/98	217/259	668/796																																																																																																																																																																																																																																												
	400/50/3	2	108/123	35/35				<b>RTWD 160</b>	380/50/3	1	235	95	103/103	259/259	796/796	380/50/3	2	132/129	35/35	<b>RTWD 160</b>	400/50/3	1	223	95	98/98	259/259	796/796	400/50/3	2	125/123	35/35	<b>RTWD 180</b>	380/50/3	1	260	120	103/123	259/291	796/896	380/50/3	2	132/154	35/50																																																																																																																																																																																																								
<b>RTWD 160</b>	380/50/3	1	235	95	103/103	259/259	796/796																																																																																																																																																																																																																																												
	380/50/3	2	132/129	35/35				<b>RTWD 160</b>	400/50/3	1	223	95	98/98	259/259	796/796	400/50/3	2	125/123	35/35	<b>RTWD 180</b>	380/50/3	1	260	120	103/123	259/291	796/896	380/50/3	2	132/154	35/50																																																																																																																																																																																																																				
<b>RTWD 160</b>	400/50/3	1	223	95	98/98	259/259	796/796																																																																																																																																																																																																																																												
	400/50/3	2	125/123	35/35				<b>RTWD 180</b>	380/50/3	1	260	120	103/123	259/291	796/896	380/50/3	2	132/154	35/50																																																																																																																																																																																																																																
<b>RTWD 180</b>	380/50/3	1	260	120	103/123	259/291	796/896																																																																																																																																																																																																																																												
	380/50/3	2	132/154	35/50																																																																																																																																																																																																																																															



## Electrical Data

**Table 18. Electrical Data - 50 Hz - high efficiency, standard condenser temperatures**

Unit ID	Rated Voltage	# Power Conns	Unit Wiring		Motor Data		
			MCA Ckt 1/Ckt 2	Wire (mm)	RLA Ckt 1/Ckt 2	LRA Y Ckt 1/Ckt 2	LRA X-L Ckt 1/Ckt 2
<b>RTWD 180</b>	400/50/3	1	247	95	98/117	259/291	796/896
	400/50/3	2	125/147	35/50			
<b>RTWD 200</b>	380/50/3	1	280	120	123/123	291/291	896/896
	380/50/3	2	157/154	50/50			
<b>RTWD 200</b>	400/50/3	1	266	120	117/117	291/291	896/896
	400/50/3	2	149/147	50/50			
<b>RTWD 220</b>	380/50/3	1	311	150	123/148	291/354	896/1089
	380/50/3	2	157/186	50/70			
<b>RTWD 220</b>	400/50/3	1	296	150	117/141	291/354	896/1089
	400/50/3	2	149/177	50/70			
<b>RTWD 250</b>	380/50/3	1	337	185	148/148	354/354	1089/1089
	380/50/3	2	188/186	70/70			
<b>RTWD 250</b>	400/50/3	1	320	150	141/141	354/354	1089/1089
	400/50/3	2	179/177	70/70			

1. MCA-Minimum Circuit Ampacity
2. RLA-Rated Load Amps.
3. LRA-Locked Rotor Amps - Based on full winding starts.
4. LRA WD-Locked Rotor Amps in Wye configuration. LRA XL-Locked Rotor Amps in the Delta configuration.
5. Local codes may take precedence.
6. Data containing information on two circuits shown as follows: circuit 1/circuit 2.
7. Standard condensing temperature option refers to entering condenser water temperatures 95°F (35°C) and below.

**Table 19. Electrical Data - 50 Hz - high efficiency, high temperature condenser**

Unit ID	Rated Voltage	# Power Conns	Unit Wiring		Motor Data																																																																																																																																																																																																																																														
			MCA Ckt 1/Ckt 2	Wire (mm)	RLA Ckt 1/Ckt 2	LRA Y Ckt 1/Ckt 2	LRA X-L Ckt 1/Ckt 2																																																																																																																																																																																																																																												
<b>RTWD 60</b>	380/50/3	1	116	35	51/51	112/112	370/370																																																																																																																																																																																																																																												
	380/50/3	2	65/63	16/16				<b>RTWD 60</b>	400/50/3	1	110	35	48/48	112/112	370/370	400/50/3	2	62/60	16/16	<b>RTWD 70</b>	380/50/3	1	140	50	61/61	129/129	427/427	380/50/3	2	79/76	16/16	<b>RTWD 70</b>	400/50/3	1	133	50	58/58	129/129	427/427	400/50/3	2	75/73	16/16	<b>RTWD 80</b>	380/50/3	1	161	70	61/78	129/144	427/462	380/50/3	2	79/97	16/25	<b>RTWD 80</b>	400/50/3	1	153	50	58/74	129/144	427/462	400/50/3	2	75/93	16/25	<b>RTWD 90</b>	380/50/3	1	177	70	78/78	144/144	462/462	380/50/3	2	100/97	25/25	<b>RTWD 90</b>	400/50/3	1	169	70	74/74	144/144	462/462	400/50/3	2	95/93	25/25	<b>RTWD 100</b>	380/50/3	1	196	95	78/93	144/180	462/589	380/50/3	2	100/116	25/35	<b>RTWD 100</b>	400/50/3	1	186	70	74/88	144/180	462/589	400/50/3	2	95/110	25/35	<b>RTWD 110</b>	380/50/3	1	211	95	93/93	180/180	589/589	380/50/3	2	118/116	35/35	<b>RTWD 110</b>	400/50/3	1	200	95	88/88	180/180	589/589	400/50/3	2	112/110	35/35	<b>RTWD 120</b>	380/50/3	1	226	95	93/105	180/217	589/668	380/50/3	2	118/132	35/50	<b>RTWD 120</b>	400/50/3	1	215	95	88/100	180/217	589/668	400/50/3	2	112/125	35/35	<b>RTWD 130</b>	380/50/3	1	232	95	102/102	217/217	668/668	380/50/3	2	130/128	50/50	<b>RTWD 130</b>	400/50/3	1	226	95	100/98	217/217	668/668	400/50/3	2	128/123	35/35	<b>RTWD 140</b>	380/50/3	1	259	120	102/124	217/259	668/796	380/50/3	2	130/155	50/70	<b>RTWD 140</b>	400/50/3	1	250	120	100/118	217/259	668/796	400/50/3	2	128/148	35/50	<b>RTWD 160</b>	380/50/3	1	281	150	124/124	259/259	796/796	380/50/3	2	157/155	70/70	<b>RTWD 160</b>	400/50/3	1	268	120	118/118	259/259	796/796	400/50/3	2	150/148	50/50	<b>RTWD 180</b>	380/50/3	1	309	150	124/147	259/291	796/896
<b>RTWD 60</b>	400/50/3	1	110	35	48/48	112/112	370/370																																																																																																																																																																																																																																												
	400/50/3	2	62/60	16/16				<b>RTWD 70</b>	380/50/3	1	140	50	61/61	129/129	427/427	380/50/3	2	79/76	16/16	<b>RTWD 70</b>	400/50/3	1	133	50	58/58	129/129	427/427	400/50/3	2	75/73	16/16	<b>RTWD 80</b>	380/50/3	1	161	70	61/78	129/144	427/462	380/50/3	2	79/97	16/25	<b>RTWD 80</b>	400/50/3	1	153	50	58/74	129/144	427/462	400/50/3	2	75/93	16/25	<b>RTWD 90</b>	380/50/3	1	177	70	78/78	144/144	462/462	380/50/3	2	100/97	25/25	<b>RTWD 90</b>	400/50/3	1	169	70	74/74	144/144	462/462	400/50/3	2	95/93	25/25	<b>RTWD 100</b>	380/50/3	1	196	95	78/93	144/180	462/589	380/50/3	2	100/116	25/35	<b>RTWD 100</b>	400/50/3	1	186	70	74/88	144/180	462/589	400/50/3	2	95/110	25/35	<b>RTWD 110</b>	380/50/3	1	211	95	93/93	180/180	589/589	380/50/3	2	118/116	35/35	<b>RTWD 110</b>	400/50/3	1	200	95	88/88	180/180	589/589	400/50/3	2	112/110	35/35	<b>RTWD 120</b>	380/50/3	1	226	95	93/105	180/217	589/668	380/50/3	2	118/132	35/50	<b>RTWD 120</b>	400/50/3	1	215	95	88/100	180/217	589/668	400/50/3	2	112/125	35/35	<b>RTWD 130</b>	380/50/3	1	232	95	102/102	217/217	668/668	380/50/3	2	130/128	50/50	<b>RTWD 130</b>	400/50/3	1	226	95	100/98	217/217	668/668	400/50/3	2	128/123	35/35	<b>RTWD 140</b>	380/50/3	1	259	120	102/124	217/259	668/796	380/50/3	2	130/155	50/70	<b>RTWD 140</b>	400/50/3	1	250	120	100/118	217/259	668/796	400/50/3	2	128/148	35/50	<b>RTWD 160</b>	380/50/3	1	281	150	124/124	259/259	796/796	380/50/3	2	157/155	70/70	<b>RTWD 160</b>	400/50/3	1	268	120	118/118	259/259	796/796	400/50/3	2	150/148	50/50	<b>RTWD 180</b>	380/50/3	1	309	150	124/147	259/291	796/896	380/50/3	2	157/183	70/70								
<b>RTWD 70</b>	380/50/3	1	140	50	61/61	129/129	427/427																																																																																																																																																																																																																																												
	380/50/3	2	79/76	16/16				<b>RTWD 70</b>	400/50/3	1	133	50	58/58	129/129	427/427	400/50/3	2	75/73	16/16	<b>RTWD 80</b>	380/50/3	1	161	70	61/78	129/144	427/462	380/50/3	2	79/97	16/25	<b>RTWD 80</b>	400/50/3	1	153	50	58/74	129/144	427/462	400/50/3	2	75/93	16/25	<b>RTWD 90</b>	380/50/3	1	177	70	78/78	144/144	462/462	380/50/3	2	100/97	25/25	<b>RTWD 90</b>	400/50/3	1	169	70	74/74	144/144	462/462	400/50/3	2	95/93	25/25	<b>RTWD 100</b>	380/50/3	1	196	95	78/93	144/180	462/589	380/50/3	2	100/116	25/35	<b>RTWD 100</b>	400/50/3	1	186	70	74/88	144/180	462/589	400/50/3	2	95/110	25/35	<b>RTWD 110</b>	380/50/3	1	211	95	93/93	180/180	589/589	380/50/3	2	118/116	35/35	<b>RTWD 110</b>	400/50/3	1	200	95	88/88	180/180	589/589	400/50/3	2	112/110	35/35	<b>RTWD 120</b>	380/50/3	1	226	95	93/105	180/217	589/668	380/50/3	2	118/132	35/50	<b>RTWD 120</b>	400/50/3	1	215	95	88/100	180/217	589/668	400/50/3	2	112/125	35/35	<b>RTWD 130</b>	380/50/3	1	232	95	102/102	217/217	668/668	380/50/3	2	130/128	50/50	<b>RTWD 130</b>	400/50/3	1	226	95	100/98	217/217	668/668	400/50/3	2	128/123	35/35	<b>RTWD 140</b>	380/50/3	1	259	120	102/124	217/259	668/796	380/50/3	2	130/155	50/70	<b>RTWD 140</b>	400/50/3	1	250	120	100/118	217/259	668/796	400/50/3	2	128/148	35/50	<b>RTWD 160</b>	380/50/3	1	281	150	124/124	259/259	796/796	380/50/3	2	157/155	70/70	<b>RTWD 160</b>	400/50/3	1	268	120	118/118	259/259	796/796	400/50/3	2	150/148	50/50	<b>RTWD 180</b>	380/50/3	1	309	150	124/147	259/291	796/896	380/50/3	2	157/183	70/70																				
<b>RTWD 70</b>	400/50/3	1	133	50	58/58	129/129	427/427																																																																																																																																																																																																																																												
	400/50/3	2	75/73	16/16				<b>RTWD 80</b>	380/50/3	1	161	70	61/78	129/144	427/462	380/50/3	2	79/97	16/25	<b>RTWD 80</b>	400/50/3	1	153	50	58/74	129/144	427/462	400/50/3	2	75/93	16/25	<b>RTWD 90</b>	380/50/3	1	177	70	78/78	144/144	462/462	380/50/3	2	100/97	25/25	<b>RTWD 90</b>	400/50/3	1	169	70	74/74	144/144	462/462	400/50/3	2	95/93	25/25	<b>RTWD 100</b>	380/50/3	1	196	95	78/93	144/180	462/589	380/50/3	2	100/116	25/35	<b>RTWD 100</b>	400/50/3	1	186	70	74/88	144/180	462/589	400/50/3	2	95/110	25/35	<b>RTWD 110</b>	380/50/3	1	211	95	93/93	180/180	589/589	380/50/3	2	118/116	35/35	<b>RTWD 110</b>	400/50/3	1	200	95	88/88	180/180	589/589	400/50/3	2	112/110	35/35	<b>RTWD 120</b>	380/50/3	1	226	95	93/105	180/217	589/668	380/50/3	2	118/132	35/50	<b>RTWD 120</b>	400/50/3	1	215	95	88/100	180/217	589/668	400/50/3	2	112/125	35/35	<b>RTWD 130</b>	380/50/3	1	232	95	102/102	217/217	668/668	380/50/3	2	130/128	50/50	<b>RTWD 130</b>	400/50/3	1	226	95	100/98	217/217	668/668	400/50/3	2	128/123	35/35	<b>RTWD 140</b>	380/50/3	1	259	120	102/124	217/259	668/796	380/50/3	2	130/155	50/70	<b>RTWD 140</b>	400/50/3	1	250	120	100/118	217/259	668/796	400/50/3	2	128/148	35/50	<b>RTWD 160</b>	380/50/3	1	281	150	124/124	259/259	796/796	380/50/3	2	157/155	70/70	<b>RTWD 160</b>	400/50/3	1	268	120	118/118	259/259	796/796	400/50/3	2	150/148	50/50	<b>RTWD 180</b>	380/50/3	1	309	150	124/147	259/291	796/896	380/50/3	2	157/183	70/70																																
<b>RTWD 80</b>	380/50/3	1	161	70	61/78	129/144	427/462																																																																																																																																																																																																																																												
	380/50/3	2	79/97	16/25				<b>RTWD 80</b>	400/50/3	1	153	50	58/74	129/144	427/462	400/50/3	2	75/93	16/25	<b>RTWD 90</b>	380/50/3	1	177	70	78/78	144/144	462/462	380/50/3	2	100/97	25/25	<b>RTWD 90</b>	400/50/3	1	169	70	74/74	144/144	462/462	400/50/3	2	95/93	25/25	<b>RTWD 100</b>	380/50/3	1	196	95	78/93	144/180	462/589	380/50/3	2	100/116	25/35	<b>RTWD 100</b>	400/50/3	1	186	70	74/88	144/180	462/589	400/50/3	2	95/110	25/35	<b>RTWD 110</b>	380/50/3	1	211	95	93/93	180/180	589/589	380/50/3	2	118/116	35/35	<b>RTWD 110</b>	400/50/3	1	200	95	88/88	180/180	589/589	400/50/3	2	112/110	35/35	<b>RTWD 120</b>	380/50/3	1	226	95	93/105	180/217	589/668	380/50/3	2	118/132	35/50	<b>RTWD 120</b>	400/50/3	1	215	95	88/100	180/217	589/668	400/50/3	2	112/125	35/35	<b>RTWD 130</b>	380/50/3	1	232	95	102/102	217/217	668/668	380/50/3	2	130/128	50/50	<b>RTWD 130</b>	400/50/3	1	226	95	100/98	217/217	668/668	400/50/3	2	128/123	35/35	<b>RTWD 140</b>	380/50/3	1	259	120	102/124	217/259	668/796	380/50/3	2	130/155	50/70	<b>RTWD 140</b>	400/50/3	1	250	120	100/118	217/259	668/796	400/50/3	2	128/148	35/50	<b>RTWD 160</b>	380/50/3	1	281	150	124/124	259/259	796/796	380/50/3	2	157/155	70/70	<b>RTWD 160</b>	400/50/3	1	268	120	118/118	259/259	796/796	400/50/3	2	150/148	50/50	<b>RTWD 180</b>	380/50/3	1	309	150	124/147	259/291	796/896	380/50/3	2	157/183	70/70																																												
<b>RTWD 80</b>	400/50/3	1	153	50	58/74	129/144	427/462																																																																																																																																																																																																																																												
	400/50/3	2	75/93	16/25				<b>RTWD 90</b>	380/50/3	1	177	70	78/78	144/144	462/462	380/50/3	2	100/97	25/25	<b>RTWD 90</b>	400/50/3	1	169	70	74/74	144/144	462/462	400/50/3	2	95/93	25/25	<b>RTWD 100</b>	380/50/3	1	196	95	78/93	144/180	462/589	380/50/3	2	100/116	25/35	<b>RTWD 100</b>	400/50/3	1	186	70	74/88	144/180	462/589	400/50/3	2	95/110	25/35	<b>RTWD 110</b>	380/50/3	1	211	95	93/93	180/180	589/589	380/50/3	2	118/116	35/35	<b>RTWD 110</b>	400/50/3	1	200	95	88/88	180/180	589/589	400/50/3	2	112/110	35/35	<b>RTWD 120</b>	380/50/3	1	226	95	93/105	180/217	589/668	380/50/3	2	118/132	35/50	<b>RTWD 120</b>	400/50/3	1	215	95	88/100	180/217	589/668	400/50/3	2	112/125	35/35	<b>RTWD 130</b>	380/50/3	1	232	95	102/102	217/217	668/668	380/50/3	2	130/128	50/50	<b>RTWD 130</b>	400/50/3	1	226	95	100/98	217/217	668/668	400/50/3	2	128/123	35/35	<b>RTWD 140</b>	380/50/3	1	259	120	102/124	217/259	668/796	380/50/3	2	130/155	50/70	<b>RTWD 140</b>	400/50/3	1	250	120	100/118	217/259	668/796	400/50/3	2	128/148	35/50	<b>RTWD 160</b>	380/50/3	1	281	150	124/124	259/259	796/796	380/50/3	2	157/155	70/70	<b>RTWD 160</b>	400/50/3	1	268	120	118/118	259/259	796/796	400/50/3	2	150/148	50/50	<b>RTWD 180</b>	380/50/3	1	309	150	124/147	259/291	796/896	380/50/3	2	157/183	70/70																																																								
<b>RTWD 90</b>	380/50/3	1	177	70	78/78	144/144	462/462																																																																																																																																																																																																																																												
	380/50/3	2	100/97	25/25				<b>RTWD 90</b>	400/50/3	1	169	70	74/74	144/144	462/462	400/50/3	2	95/93	25/25	<b>RTWD 100</b>	380/50/3	1	196	95	78/93	144/180	462/589	380/50/3	2	100/116	25/35	<b>RTWD 100</b>	400/50/3	1	186	70	74/88	144/180	462/589	400/50/3	2	95/110	25/35	<b>RTWD 110</b>	380/50/3	1	211	95	93/93	180/180	589/589	380/50/3	2	118/116	35/35	<b>RTWD 110</b>	400/50/3	1	200	95	88/88	180/180	589/589	400/50/3	2	112/110	35/35	<b>RTWD 120</b>	380/50/3	1	226	95	93/105	180/217	589/668	380/50/3	2	118/132	35/50	<b>RTWD 120</b>	400/50/3	1	215	95	88/100	180/217	589/668	400/50/3	2	112/125	35/35	<b>RTWD 130</b>	380/50/3	1	232	95	102/102	217/217	668/668	380/50/3	2	130/128	50/50	<b>RTWD 130</b>	400/50/3	1	226	95	100/98	217/217	668/668	400/50/3	2	128/123	35/35	<b>RTWD 140</b>	380/50/3	1	259	120	102/124	217/259	668/796	380/50/3	2	130/155	50/70	<b>RTWD 140</b>	400/50/3	1	250	120	100/118	217/259	668/796	400/50/3	2	128/148	35/50	<b>RTWD 160</b>	380/50/3	1	281	150	124/124	259/259	796/796	380/50/3	2	157/155	70/70	<b>RTWD 160</b>	400/50/3	1	268	120	118/118	259/259	796/796	400/50/3	2	150/148	50/50	<b>RTWD 180</b>	380/50/3	1	309	150	124/147	259/291	796/896	380/50/3	2	157/183	70/70																																																																				
<b>RTWD 90</b>	400/50/3	1	169	70	74/74	144/144	462/462																																																																																																																																																																																																																																												
	400/50/3	2	95/93	25/25				<b>RTWD 100</b>	380/50/3	1	196	95	78/93	144/180	462/589	380/50/3	2	100/116	25/35	<b>RTWD 100</b>	400/50/3	1	186	70	74/88	144/180	462/589	400/50/3	2	95/110	25/35	<b>RTWD 110</b>	380/50/3	1	211	95	93/93	180/180	589/589	380/50/3	2	118/116	35/35	<b>RTWD 110</b>	400/50/3	1	200	95	88/88	180/180	589/589	400/50/3	2	112/110	35/35	<b>RTWD 120</b>	380/50/3	1	226	95	93/105	180/217	589/668	380/50/3	2	118/132	35/50	<b>RTWD 120</b>	400/50/3	1	215	95	88/100	180/217	589/668	400/50/3	2	112/125	35/35	<b>RTWD 130</b>	380/50/3	1	232	95	102/102	217/217	668/668	380/50/3	2	130/128	50/50	<b>RTWD 130</b>	400/50/3	1	226	95	100/98	217/217	668/668	400/50/3	2	128/123	35/35	<b>RTWD 140</b>	380/50/3	1	259	120	102/124	217/259	668/796	380/50/3	2	130/155	50/70	<b>RTWD 140</b>	400/50/3	1	250	120	100/118	217/259	668/796	400/50/3	2	128/148	35/50	<b>RTWD 160</b>	380/50/3	1	281	150	124/124	259/259	796/796	380/50/3	2	157/155	70/70	<b>RTWD 160</b>	400/50/3	1	268	120	118/118	259/259	796/796	400/50/3	2	150/148	50/50	<b>RTWD 180</b>	380/50/3	1	309	150	124/147	259/291	796/896	380/50/3	2	157/183	70/70																																																																																
<b>RTWD 100</b>	380/50/3	1	196	95	78/93	144/180	462/589																																																																																																																																																																																																																																												
	380/50/3	2	100/116	25/35				<b>RTWD 100</b>	400/50/3	1	186	70	74/88	144/180	462/589	400/50/3	2	95/110	25/35	<b>RTWD 110</b>	380/50/3	1	211	95	93/93	180/180	589/589	380/50/3	2	118/116	35/35	<b>RTWD 110</b>	400/50/3	1	200	95	88/88	180/180	589/589	400/50/3	2	112/110	35/35	<b>RTWD 120</b>	380/50/3	1	226	95	93/105	180/217	589/668	380/50/3	2	118/132	35/50	<b>RTWD 120</b>	400/50/3	1	215	95	88/100	180/217	589/668	400/50/3	2	112/125	35/35	<b>RTWD 130</b>	380/50/3	1	232	95	102/102	217/217	668/668	380/50/3	2	130/128	50/50	<b>RTWD 130</b>	400/50/3	1	226	95	100/98	217/217	668/668	400/50/3	2	128/123	35/35	<b>RTWD 140</b>	380/50/3	1	259	120	102/124	217/259	668/796	380/50/3	2	130/155	50/70	<b>RTWD 140</b>	400/50/3	1	250	120	100/118	217/259	668/796	400/50/3	2	128/148	35/50	<b>RTWD 160</b>	380/50/3	1	281	150	124/124	259/259	796/796	380/50/3	2	157/155	70/70	<b>RTWD 160</b>	400/50/3	1	268	120	118/118	259/259	796/796	400/50/3	2	150/148	50/50	<b>RTWD 180</b>	380/50/3	1	309	150	124/147	259/291	796/896	380/50/3	2	157/183	70/70																																																																																												
<b>RTWD 100</b>	400/50/3	1	186	70	74/88	144/180	462/589																																																																																																																																																																																																																																												
	400/50/3	2	95/110	25/35				<b>RTWD 110</b>	380/50/3	1	211	95	93/93	180/180	589/589	380/50/3	2	118/116	35/35	<b>RTWD 110</b>	400/50/3	1	200	95	88/88	180/180	589/589	400/50/3	2	112/110	35/35	<b>RTWD 120</b>	380/50/3	1	226	95	93/105	180/217	589/668	380/50/3	2	118/132	35/50	<b>RTWD 120</b>	400/50/3	1	215	95	88/100	180/217	589/668	400/50/3	2	112/125	35/35	<b>RTWD 130</b>	380/50/3	1	232	95	102/102	217/217	668/668	380/50/3	2	130/128	50/50	<b>RTWD 130</b>	400/50/3	1	226	95	100/98	217/217	668/668	400/50/3	2	128/123	35/35	<b>RTWD 140</b>	380/50/3	1	259	120	102/124	217/259	668/796	380/50/3	2	130/155	50/70	<b>RTWD 140</b>	400/50/3	1	250	120	100/118	217/259	668/796	400/50/3	2	128/148	35/50	<b>RTWD 160</b>	380/50/3	1	281	150	124/124	259/259	796/796	380/50/3	2	157/155	70/70	<b>RTWD 160</b>	400/50/3	1	268	120	118/118	259/259	796/796	400/50/3	2	150/148	50/50	<b>RTWD 180</b>	380/50/3	1	309	150	124/147	259/291	796/896	380/50/3	2	157/183	70/70																																																																																																								
<b>RTWD 110</b>	380/50/3	1	211	95	93/93	180/180	589/589																																																																																																																																																																																																																																												
	380/50/3	2	118/116	35/35				<b>RTWD 110</b>	400/50/3	1	200	95	88/88	180/180	589/589	400/50/3	2	112/110	35/35	<b>RTWD 120</b>	380/50/3	1	226	95	93/105	180/217	589/668	380/50/3	2	118/132	35/50	<b>RTWD 120</b>	400/50/3	1	215	95	88/100	180/217	589/668	400/50/3	2	112/125	35/35	<b>RTWD 130</b>	380/50/3	1	232	95	102/102	217/217	668/668	380/50/3	2	130/128	50/50	<b>RTWD 130</b>	400/50/3	1	226	95	100/98	217/217	668/668	400/50/3	2	128/123	35/35	<b>RTWD 140</b>	380/50/3	1	259	120	102/124	217/259	668/796	380/50/3	2	130/155	50/70	<b>RTWD 140</b>	400/50/3	1	250	120	100/118	217/259	668/796	400/50/3	2	128/148	35/50	<b>RTWD 160</b>	380/50/3	1	281	150	124/124	259/259	796/796	380/50/3	2	157/155	70/70	<b>RTWD 160</b>	400/50/3	1	268	120	118/118	259/259	796/796	400/50/3	2	150/148	50/50	<b>RTWD 180</b>	380/50/3	1	309	150	124/147	259/291	796/896	380/50/3	2	157/183	70/70																																																																																																																				
<b>RTWD 110</b>	400/50/3	1	200	95	88/88	180/180	589/589																																																																																																																																																																																																																																												
	400/50/3	2	112/110	35/35				<b>RTWD 120</b>	380/50/3	1	226	95	93/105	180/217	589/668	380/50/3	2	118/132	35/50	<b>RTWD 120</b>	400/50/3	1	215	95	88/100	180/217	589/668	400/50/3	2	112/125	35/35	<b>RTWD 130</b>	380/50/3	1	232	95	102/102	217/217	668/668	380/50/3	2	130/128	50/50	<b>RTWD 130</b>	400/50/3	1	226	95	100/98	217/217	668/668	400/50/3	2	128/123	35/35	<b>RTWD 140</b>	380/50/3	1	259	120	102/124	217/259	668/796	380/50/3	2	130/155	50/70	<b>RTWD 140</b>	400/50/3	1	250	120	100/118	217/259	668/796	400/50/3	2	128/148	35/50	<b>RTWD 160</b>	380/50/3	1	281	150	124/124	259/259	796/796	380/50/3	2	157/155	70/70	<b>RTWD 160</b>	400/50/3	1	268	120	118/118	259/259	796/796	400/50/3	2	150/148	50/50	<b>RTWD 180</b>	380/50/3	1	309	150	124/147	259/291	796/896	380/50/3	2	157/183	70/70																																																																																																																																
<b>RTWD 120</b>	380/50/3	1	226	95	93/105	180/217	589/668																																																																																																																																																																																																																																												
	380/50/3	2	118/132	35/50				<b>RTWD 120</b>	400/50/3	1	215	95	88/100	180/217	589/668	400/50/3	2	112/125	35/35	<b>RTWD 130</b>	380/50/3	1	232	95	102/102	217/217	668/668	380/50/3	2	130/128	50/50	<b>RTWD 130</b>	400/50/3	1	226	95	100/98	217/217	668/668	400/50/3	2	128/123	35/35	<b>RTWD 140</b>	380/50/3	1	259	120	102/124	217/259	668/796	380/50/3	2	130/155	50/70	<b>RTWD 140</b>	400/50/3	1	250	120	100/118	217/259	668/796	400/50/3	2	128/148	35/50	<b>RTWD 160</b>	380/50/3	1	281	150	124/124	259/259	796/796	380/50/3	2	157/155	70/70	<b>RTWD 160</b>	400/50/3	1	268	120	118/118	259/259	796/796	400/50/3	2	150/148	50/50	<b>RTWD 180</b>	380/50/3	1	309	150	124/147	259/291	796/896	380/50/3	2	157/183	70/70																																																																																																																																												
<b>RTWD 120</b>	400/50/3	1	215	95	88/100	180/217	589/668																																																																																																																																																																																																																																												
	400/50/3	2	112/125	35/35				<b>RTWD 130</b>	380/50/3	1	232	95	102/102	217/217	668/668	380/50/3	2	130/128	50/50	<b>RTWD 130</b>	400/50/3	1	226	95	100/98	217/217	668/668	400/50/3	2	128/123	35/35	<b>RTWD 140</b>	380/50/3	1	259	120	102/124	217/259	668/796	380/50/3	2	130/155	50/70	<b>RTWD 140</b>	400/50/3	1	250	120	100/118	217/259	668/796	400/50/3	2	128/148	35/50	<b>RTWD 160</b>	380/50/3	1	281	150	124/124	259/259	796/796	380/50/3	2	157/155	70/70	<b>RTWD 160</b>	400/50/3	1	268	120	118/118	259/259	796/796	400/50/3	2	150/148	50/50	<b>RTWD 180</b>	380/50/3	1	309	150	124/147	259/291	796/896	380/50/3	2	157/183	70/70																																																																																																																																																								
<b>RTWD 130</b>	380/50/3	1	232	95	102/102	217/217	668/668																																																																																																																																																																																																																																												
	380/50/3	2	130/128	50/50				<b>RTWD 130</b>	400/50/3	1	226	95	100/98	217/217	668/668	400/50/3	2	128/123	35/35	<b>RTWD 140</b>	380/50/3	1	259	120	102/124	217/259	668/796	380/50/3	2	130/155	50/70	<b>RTWD 140</b>	400/50/3	1	250	120	100/118	217/259	668/796	400/50/3	2	128/148	35/50	<b>RTWD 160</b>	380/50/3	1	281	150	124/124	259/259	796/796	380/50/3	2	157/155	70/70	<b>RTWD 160</b>	400/50/3	1	268	120	118/118	259/259	796/796	400/50/3	2	150/148	50/50	<b>RTWD 180</b>	380/50/3	1	309	150	124/147	259/291	796/896	380/50/3	2	157/183	70/70																																																																																																																																																																				
<b>RTWD 130</b>	400/50/3	1	226	95	100/98	217/217	668/668																																																																																																																																																																																																																																												
	400/50/3	2	128/123	35/35				<b>RTWD 140</b>	380/50/3	1	259	120	102/124	217/259	668/796	380/50/3	2	130/155	50/70	<b>RTWD 140</b>	400/50/3	1	250	120	100/118	217/259	668/796	400/50/3	2	128/148	35/50	<b>RTWD 160</b>	380/50/3	1	281	150	124/124	259/259	796/796	380/50/3	2	157/155	70/70	<b>RTWD 160</b>	400/50/3	1	268	120	118/118	259/259	796/796	400/50/3	2	150/148	50/50	<b>RTWD 180</b>	380/50/3	1	309	150	124/147	259/291	796/896	380/50/3	2	157/183	70/70																																																																																																																																																																																
<b>RTWD 140</b>	380/50/3	1	259	120	102/124	217/259	668/796																																																																																																																																																																																																																																												
	380/50/3	2	130/155	50/70				<b>RTWD 140</b>	400/50/3	1	250	120	100/118	217/259	668/796	400/50/3	2	128/148	35/50	<b>RTWD 160</b>	380/50/3	1	281	150	124/124	259/259	796/796	380/50/3	2	157/155	70/70	<b>RTWD 160</b>	400/50/3	1	268	120	118/118	259/259	796/796	400/50/3	2	150/148	50/50	<b>RTWD 180</b>	380/50/3	1	309	150	124/147	259/291	796/896	380/50/3	2	157/183	70/70																																																																																																																																																																																												
<b>RTWD 140</b>	400/50/3	1	250	120	100/118	217/259	668/796																																																																																																																																																																																																																																												
	400/50/3	2	128/148	35/50				<b>RTWD 160</b>	380/50/3	1	281	150	124/124	259/259	796/796	380/50/3	2	157/155	70/70	<b>RTWD 160</b>	400/50/3	1	268	120	118/118	259/259	796/796	400/50/3	2	150/148	50/50	<b>RTWD 180</b>	380/50/3	1	309	150	124/147	259/291	796/896	380/50/3	2	157/183	70/70																																																																																																																																																																																																								
<b>RTWD 160</b>	380/50/3	1	281	150	124/124	259/259	796/796																																																																																																																																																																																																																																												
	380/50/3	2	157/155	70/70				<b>RTWD 160</b>	400/50/3	1	268	120	118/118	259/259	796/796	400/50/3	2	150/148	50/50	<b>RTWD 180</b>	380/50/3	1	309	150	124/147	259/291	796/896	380/50/3	2	157/183	70/70																																																																																																																																																																																																																				
<b>RTWD 160</b>	400/50/3	1	268	120	118/118	259/259	796/796																																																																																																																																																																																																																																												
	400/50/3	2	150/148	50/50				<b>RTWD 180</b>	380/50/3	1	309	150	124/147	259/291	796/896	380/50/3	2	157/183	70/70																																																																																																																																																																																																																																
<b>RTWD 180</b>	380/50/3	1	309	150	124/147	259/291	796/896																																																																																																																																																																																																																																												
	380/50/3	2	157/183	70/70																																																																																																																																																																																																																																															



## Electrical Data

**Table 19. Electrical Data - 50 Hz - high efficiency, high temperature condenser**

Unit ID	Rated Voltage	# Power Conns	Unit Wiring		Motor Data																																																																						
			MCA Ckt 1/Ckt 2	Wire (mm)	RLA Ckt 1/Ckt 2	LRA Y Ckt 1/Ckt 2	LRA X-L Ckt 1/Ckt 2																																																																				
<b>RTWD 180</b>	400/50/3	1	297	150	118/141	259/291	796/896																																																																				
	400/50/3	2	150/177	50/70				<b>RTWD 200</b>	380/50/3	1	332	185	147/147	291/291	896/896	380/50/3	2	185/183	75/75	<b>RTWD 200</b>	400/50/3	1	320	150	141/141	291/291	896/896	400/50/3	2	179/177	70/70	<b>RTWD 220</b>	380/50/3	1	367	240	147/175	291/354	896/1089	380/50/3	2	185/219	70/95	<b>RTWD 220</b>	400/50/3	1	352	185	141/167	291/354	896/1089	400/50/3	2	179/209	70/95	<b>RTWD 250</b>	380/50/3	1	396	240	175/175	354/354	1089/1089	380/50/3	2	221/219	95/95	<b>RTWD 250</b>	400/50/3	1	378	240	167/167	354/354	1089/1089
<b>RTWD 200</b>	380/50/3	1	332	185	147/147	291/291	896/896																																																																				
	380/50/3	2	185/183	75/75				<b>RTWD 200</b>	400/50/3	1	320	150	141/141	291/291	896/896	400/50/3	2	179/177	70/70	<b>RTWD 220</b>	380/50/3	1	367	240	147/175	291/354	896/1089	380/50/3	2	185/219	70/95	<b>RTWD 220</b>	400/50/3	1	352	185	141/167	291/354	896/1089	400/50/3	2	179/209	70/95	<b>RTWD 250</b>	380/50/3	1	396	240	175/175	354/354	1089/1089	380/50/3	2	221/219	95/95	<b>RTWD 250</b>	400/50/3	1	378	240	167/167	354/354	1089/1089	400/50/3	2	211/209	95/95								
<b>RTWD 200</b>	400/50/3	1	320	150	141/141	291/291	896/896																																																																				
	400/50/3	2	179/177	70/70				<b>RTWD 220</b>	380/50/3	1	367	240	147/175	291/354	896/1089	380/50/3	2	185/219	70/95	<b>RTWD 220</b>	400/50/3	1	352	185	141/167	291/354	896/1089	400/50/3	2	179/209	70/95	<b>RTWD 250</b>	380/50/3	1	396	240	175/175	354/354	1089/1089	380/50/3	2	221/219	95/95	<b>RTWD 250</b>	400/50/3	1	378	240	167/167	354/354	1089/1089	400/50/3	2	211/209	95/95																				
<b>RTWD 220</b>	380/50/3	1	367	240	147/175	291/354	896/1089																																																																				
	380/50/3	2	185/219	70/95				<b>RTWD 220</b>	400/50/3	1	352	185	141/167	291/354	896/1089	400/50/3	2	179/209	70/95	<b>RTWD 250</b>	380/50/3	1	396	240	175/175	354/354	1089/1089	380/50/3	2	221/219	95/95	<b>RTWD 250</b>	400/50/3	1	378	240	167/167	354/354	1089/1089	400/50/3	2	211/209	95/95																																
<b>RTWD 220</b>	400/50/3	1	352	185	141/167	291/354	896/1089																																																																				
	400/50/3	2	179/209	70/95				<b>RTWD 250</b>	380/50/3	1	396	240	175/175	354/354	1089/1089	380/50/3	2	221/219	95/95	<b>RTWD 250</b>	400/50/3	1	378	240	167/167	354/354	1089/1089	400/50/3	2	211/209	95/95																																												
<b>RTWD 250</b>	380/50/3	1	396	240	175/175	354/354	1089/1089																																																																				
	380/50/3	2	221/219	95/95				<b>RTWD 250</b>	400/50/3	1	378	240	167/167	354/354	1089/1089	400/50/3	2	211/209	95/95																																																								
<b>RTWD 250</b>	400/50/3	1	378	240	167/167	354/354	1089/1089																																																																				
	400/50/3	2	211/209	95/95																																																																							

1. MCA-Minimum Circuit Ampacity
2. RLA-Rated Load Amps.
3. LRA-Locked Rotor Amps - Based on full winding starts.
4. LRA WD-Locked Rotor Amps in Wye configuration. LRA XL-Locked Rotor Amps in the Delta configuration.
5. Local codes may take precedence.
6. Data containing information on two circuits shown as follows: circuit 1/circuit 2.
7. High temperature condenser refers to entering condenser water temperatures 95°F (35°C) and above.



**Table 20. Electrical Data – 50 Hz – premium efficiency, standard condensing temperature**

Unit ID	Rated Voltage	# Power Conns	Unit Wiring		Motor Data		
			MCA Ckt 1/Ckt 2	Wire (mm)	RLA Ckt 1/Ckt 2	LRA WD Ckt 1/Ckt 2	LRA XL Ckt 1/Ckt 2
<b>RTWD 160</b>	380/50/3	1	232	95	102/105	259/259	796/796
	380/50/3	2	130/128	35/35			
<b>RTWD 160</b>	400/50/3	1	221	95	97/97	259/259	796/796
	400/50/3	2	124/122	35/35			
<b>RTWD 180</b>	380/50/3	1	259	120	102/123	259/21	796/896
	380/50/3	2	130/154	35/50			
<b>RTWD 180</b>	400/50/3	1	246	95	97/117	259/291	796/896
	400/50/3	2	124/147	35/50			
<b>RTWD 200</b>	380/50/3	1	280	120	123/123	291/291	896/896
	380/50/3	2	157/154	50/50			
<b>RTWD 200</b>	400/50/3	1	266	120	117/117	291/291	896/896
	400/50/3	2	149/147	50/50			

1. MCA–minimum circuit ampacity
2. RLA–rated load amps are rated in accordance with UL Standard 1995.
3. LRA–locked rotor amps are based on full winding starts.
4. LRA WD–Locked Rotor Amps in Wye configuration. LRA XL–Locked Rotor Amps in the Delta configuration.
5. Local codes may take precedence.
6. Data containing information on two circuits shown as follows: circuit 1/circuit 2.
7. Standard condensing temperature option refers to entering condenser water temperatures 95°F (35°C) and below.

**Table 21. Electrical Data – 50 Hz – premium efficiency, high condensing temperature**

Unit ID	Rated Voltage	# Power Conns	Unit Wiring		Motor Data		
			MCA Ckt 1/Ckt 2	Wire (mm)	RLA Ckt 1/Ckt 2	LRA WD Ckt 1/Ckt 2	LRA XL Ckt 1/Ckt 2
<b>RTWD 160</b>	380/50/3	1	280	150	123/123	259/259	796/796
	380/50/3	2	156/154	70/70			
<b>RTWD 160</b>	400/50/3	1	268	120	118/118	259/259	796/796
	400/50/3	2	150/148	50/50			
<b>RTWD 180</b>	380/50/3	1	308	150	123/146	259/291	796/896
	380/50/3	2	156/183	70/70			
<b>RTWD 180</b>	400/50/3	1	297	150	118/141	259/291	796/896
	400/50/3	2	150/177	50/70			
<b>RTWD 200</b>	380/50/3	1	331	185	146/146	291/291	896/896
	380/50/3	2	185/183	70/70			
<b>RTWD 200</b>	400/50/3	1	320	150	141/141	291/291	896/896
	400/50/3	2	179/177	70/70			

1. MCA–minimum circuit ampacity
2. RLA–rated load amps are rated in accordance with UL Standard 1995.
3. LRA–locked rotor amps are based on full winding starts.
4. LRA WD–Locked Rotor Amps in Wye configuration. LRA XL–Locked Rotor Amps in the Delta configuration.
5. Local codes may take precedence.
6. Data containing information on two circuits shown as follows: circuit 1/circuit 2.
7. High condensing temperature option refers to entering condenser water temperatures above 95°F (35°C).

# Electrical Connections

Figure 1. Field Wiring Diagram

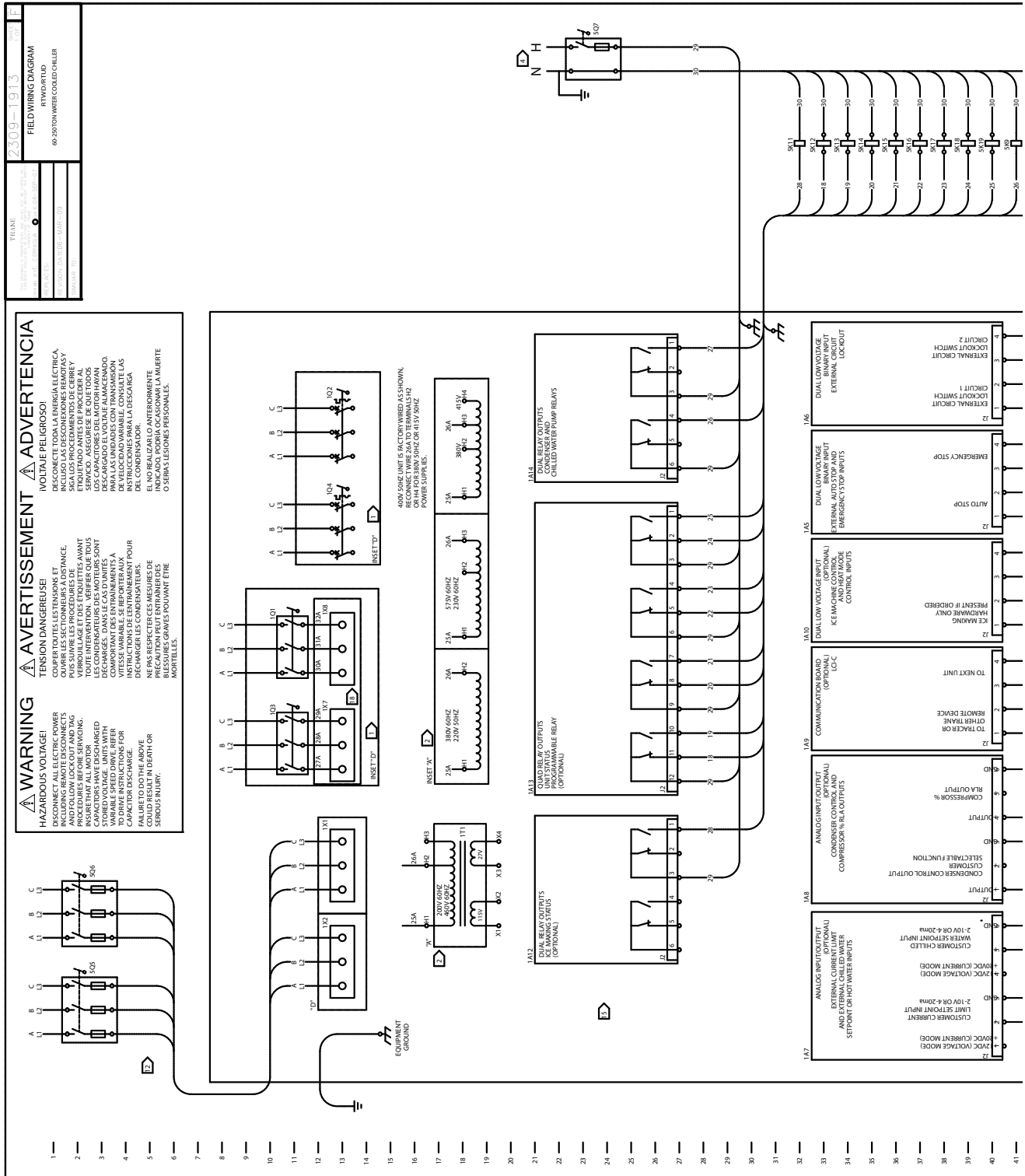

**Figure 2. Field Wiring Diagram (continued)**

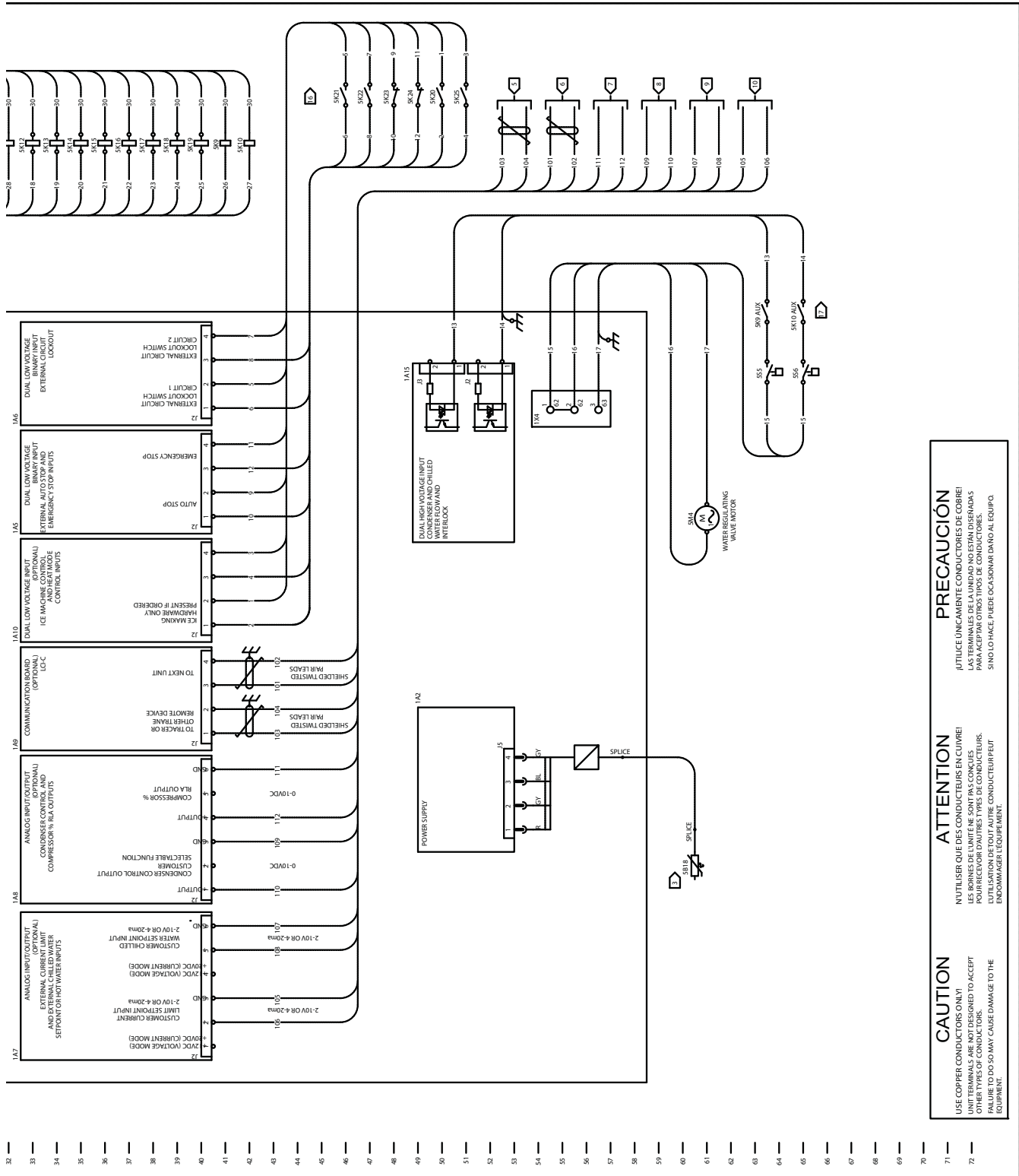

**CAUTION**  
USE COPPER CONDUCTORS ONLY!  
UNIT TERMINALS ARE NOT DESIGNED TO ACCEPT  
OTHER TYPES OF CONDUCTORS.  
FAILURE TO ACCEPT ONLY THE CONDUCTOR TYPE  
EQUIPMENT.  
FAILURE TO DO SO MAY CAUSE DAMAGE TO THE  
EQUIPMENT.

**ATTENTION**  
N'UTILISER QUE DES CONDUCTEURS EN CUIVRE!  
LES BORNES DE LIMITE NE SONT PAS CONÇUES  
POUR ACCEPTER D'AUTRES TYPES DE CONDUCTEURS.  
L'ÉQUIPEMENT NE PEUT ACCEPTER QUE LE TYPE DE  
CONDUCTEURS ÉQUIPÉMENT.

**PRECAUCIÓN**  
UTILICE ÚNICAMENTE CONDUCTORES DE COBRE!  
LAS TERMINALES DE LA UNIDAD NO ESTÁN DISEÑADAS  
PARA ACEPTAR OTROS TIPOS DE CONDUCTORES.  
EL EQUIPAMIENTO NO PUEDE ACEPTAR OTROS TIPOS DE  
SINO LO QUE PUEDE OCASIONAR DAÑO AL EQUIPO.



## Electrical Connections

**Table 22. Field Wiring Diagram Notes**

#	Description
1	Single source power is provided as standard on these products, dual source power is optional. Field connections for single source power are made to 1X1, 1Q1, or 1Q2. When dual source power is selected the field connections for circuit #2 are made to 1X2, 1Q3, or 1Q4.
2	400 V/50 Hz unit is factory wired with 26A connected to H3 - reconnect wire 26A to H2 for 380V/50Hz, or H4 for 415V/50Hz. H4 is only available with 400V/50Hz panels.
3	Factory installed outdoor air temperature sensor lead length to be spliced and extended by customer.
4	Customer supplied power 220/50/1 to power relays. Max fuse size is 15 amps. Ground all customer supplied power supplied as required by applicable codes. green ground screws are provided in unit control panel.
5	Wired to next unit. 22 AWG shielded communication wire equivalent to helix LF22P0014216 recommended. The sum total of all interconnected cable segments not to exceed 4500 feet. Connection topology should be daisy chain. Refer to building automation system (BAS) communication installation literature for end of line termination resistor requirements.
6	Wired to Tracer or other Trane remote device. 22 AWG shielded communication wire equivalent to helix LF22P0014216 recommended. The sum total of all interconnected cable segments not to exceed 4500 feet. Connection topology should be daisy chain. Refer to building automation system (BAS) communication installation literature for end of line termination resistor requirements
7	Wired to compressor % RLA.
8	Wired to condenser control customer selectable function.
9	Wired to customer chilled water setpoint 2-10 V or 4-20 mA.
10	Wired to customer current limit setpoint 2-10 V or 4-20 mA.
11	Refer to RTWD electrical schematic for specific electrical connection information and notes pertaining to wiring installation.
12	All unit power wiring must be 600 volt copper conductors only and have a minimum temperature insulation rating of 90°C. Refer to unit nameplate for minimum circuit ampacity and maximum overcurrent protection device. Provide an equipment ground in accordance with applicable electric codes.
13	All field wiring must be in accordance with national electric code and local requirements.
14	All customer control circuit wiring must be copper conductors only and have a minimum insulation rating of 300 volts. Except as noted, all customer wiring connection are made to circuit board mounted box lugs with a wire range of 14 to 18 AWG.
15	Unit provided dry contacts for the condenser/chilled water pump control. Relays are rated for 7.2 amps resistive, 2.88 amps pilot duty, or 1/3 HP, 7.2 FLA at 120 volts 60Hz. Contacts are rated for 5 amps general purpose duty 240 volts.
16	Customer supplied contacts for all low voltage connections must be compatible with dry circuit 24 volts DC for a 12 mA resistive load. Silver or gold plated contacts recommended.
17	Flow switch and interlock contacts must be acceptable for use in a 120 volt 1 mA circuit or a 220 volt 2 mA circuit.
18	Only present on "ED" frame molded case switches. 1X7, 1X8, 27A, 28A, 29A, 30A, 31A, and 32A are not present with all other molded case switches.
1A2	Power supply.
1A5	External auto stop and emergency stop inputs, dual low voltage binary input.
1A6	External circuit lockout, circuit 1 and 2, dual low voltage binary input.
1A7	External current limit and external chilled water setpoint or hot water inputs, analog input/output (optional).
1A8	Condenser control and compressor % RLA output, analog input/output (optional).
1A9	LCI-C or Tracer communications, communication board (optional).
1A10	Ice machine control and heat mode control inputs, dual low voltage (optional).
1A12	Ice making status, dual relay outputs (optional).
1A13	Unit status, programmable relay, quad relay outputs (optional).
1A14	Condenser and chilled water pump relays, dual relay outputs.
1A15	Condenser and chilled water flow and interlock, dual high voltage input.

**Replaceable Fuse Table**

<b>Volts</b>	<b>Hertz</b>	<b>Designation</b>	<b>Class</b>	<b>Quantity</b>	<b>Size (A)</b>
<b>400</b>	<b>50</b>	1F13, 14	CC	2	5
		1F18, 19, 20, 21	CC	4	3
		1F16, 17	CC	2	6
		1F15	CC	1	10

# Electrical Connections

Figure 3. Connection Diagram

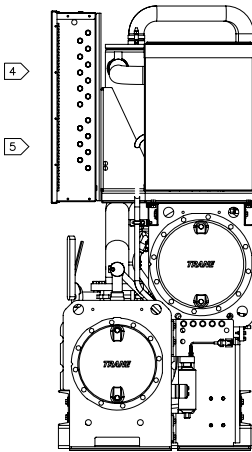
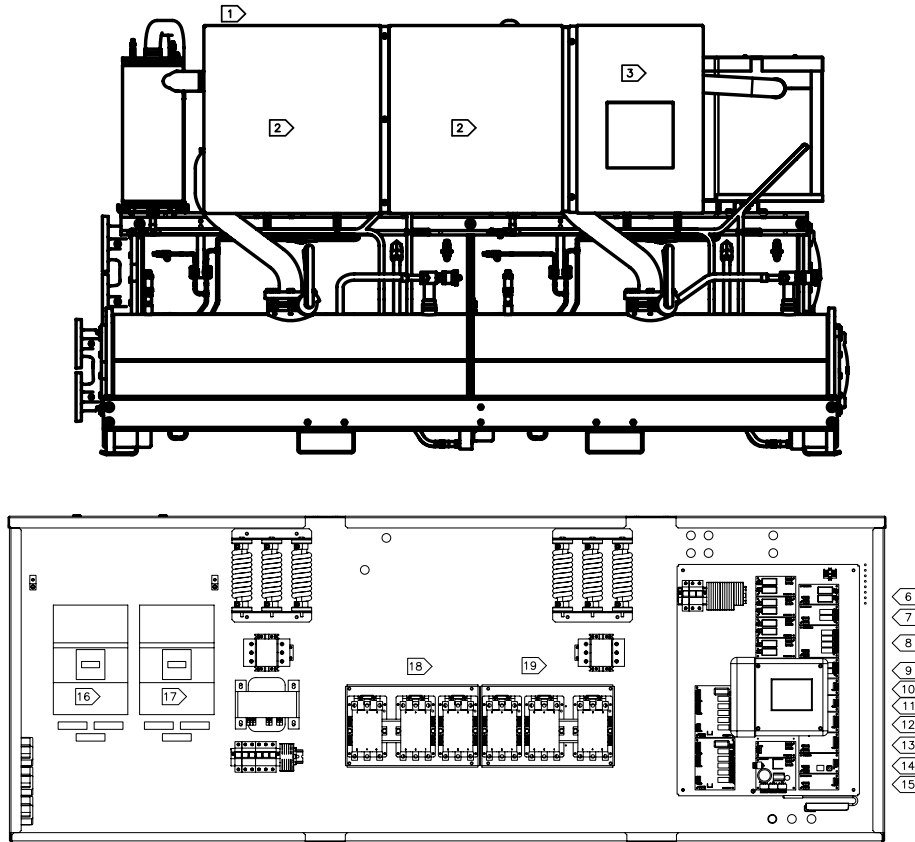

**CAUTION**

USE COPPER CONDUCTORS ONLY!  
 UNIT TERMINALS ARE NOT DESIGNED TO ACCEPT OTHER TYPES OF CONDUCTORS.  
 FAILURE TO DO SO MAY CAUSE DAMAGE TO THE EQUIPMENT.

**ATTENTION**

N'UTILISER QUE DES CONDUCTEURS EN CUIVRE!  
 LES BORNES DE L'UNITÉ NE SONT PAS CONÇUES POUR RECEVOIR D'AUTRES TYPES DE CONDUCTEURS.  
 L'UTILISATION DE TOUT AUTRE CONDUCTEUR PEUT ENDOMMAGER L'EQUIPEMENT.

**PRECAUCIÓN**

¡UTILICE ÚNICAMENTE CONDUCTORES DE COBRE!  
 LAS TERMINALES DE LA UNIDAD NO ESTÁN DISEÑADAS PARA ACEPTAR OTROS TIPOS DE CONDUCTORES.  
 SI NO LO HACE, PUEDE OCASIONAR DAÑO AL EQUIPO.

**WARNING**

HAZARDOUS VOLTAGE!  
 DISCONNECT ALL ELECTRIC POWER INCLUDING REMOTE DISCONNECTS AND FOLLOW LOCK OUT AND TAG PROCEDURES BEFORE SERVICING. INSURE THAT ALL MOTOR CAPACITORS HAVE DISCHARGED STORED VOLTAGE. UNITS WITH VARIABLE SPEED DRIVE; REFER TO DRIVE INSTRUCTIONS FOR CAPACITOR DISCHARGE. FAILURE TO DO THE ABOVE COULD RESULT IN DEATH OR SERIOUS INJURY.

**AVERTISSEMENT**

TENSION DANGEREUSE!  
 COUPER TOUTES LES TENSIONS ET OUVRIR LES SECTIONNEURS À DISTANCE, PUIS SUIVRE LES PROCEDURES DE VERROUILLAGE ET DES ÉTIQUETTES AVANT TOUTE INTERVENTION. VÉRIFIER QUE TOUTS LES CONDENSATEURS DES MOTEURS SONT DÉCHARGÉS. DANS LE CAS D'UNITÉS COMPORTANT DES ENTRAÎNEMENTS À VITESSE VARIABLE, SE REPORTER AUX INSTRUCTIONS DE L'ENTRAÎNEMENT POUR DÉCHARGER LES CONDENSATEURS.  
 NE PAS RESPECTER CES MESURES DE PRECAUTION PEUT ENTRAÎNER DES BLESSURES GRAVES POUVANT ÊTRE MORTELLES.

**ADVERTENCIA**

¡VOLTAJE PELIGROSO!  
 DESCONECTE TODA LA ENERGÍA ELÉCTRICA, INCLUIDO LAS DESCONEXIONES REMOTAS Y SIGA LOS PROCEDIMIENTOS DE CIERRE Y ETIQUETADO ANTES DE PROCEDER AL SERVICIO. ASEGÚRESE DE QUE TODOS LOS CAPACITORES DEL MOTOR HAYAN DESCARGADO EL VOLTAJE ALMACENADO. PARA LAS UNIDADES CON TRANSMISIÓN DE VELOCIDAD VARIABLE, CONSULTE LAS INSTRUCCIONES PARA LA DESCARGA DEL CONDENSADOR.  
 EL NO REALIZAR LO ANTERIORMENTE INDICADO, PODRÍA OCASIONAR LA MUERTE O SERIAS LESIONES PERSONALES.

**Table 23. Connection Diagram Notes**

#	Description		Additional Information
1	Line voltage entrance (see unit nameplate)	location	
2	Power section	location	
3	Controls section	location	
4	Customer control power high voltage entrance	location	
5	Customer control power low voltage entrance	location	
6	Condenser and chilled water flow inputs.	optional	1A15, (5K10 and 5K9)
7	Condenser and chilled water pump relay outputs. Separate 220/50/1 customer power is required.	optional	1A14, (5K10 and 5K9)
8	Unit status programmable relay outputs. Separate 220/50/1 customer power is required.	optional	1A13, (5K12–5K19)
9	Ice making status relay output. Separate 220/50/1 customer power is required.	optional	1A12, (5K11)
10	External auto stop and emergency stop inputs.	standard	1A5, (5K23 and 5K24)
11	External circuit lockout inputs circuit 1 and circuit 2.	standard	1A6, (5K21 and 5K22)
12	External current-limit and chilled water setpoint or hot water inputs.	optional	1A7, (4-20 mA or 2-10 V)
13	Condenser control and compressor % RLA input.	optional	1A8, (4-20 mA or 0-10 V)
14	Tracer Communications	optional	1A9
15	Ice machine control and heat mode control.	optional	1A10, (5K20 and 5K25)
16	Circuit 1 disconnect	optional	1A6
17	Circuit 2 disconnect	optional	1A6
18	Wye-delta closed transition starter or across-the-line starter circuit 1A	location	
19	Wye-delta closed transition starter or across-the-line starter circuit 2A	location	
20	Refer to RTWD electrical schematic for specific electrical connection information and notes pertaining to wiring installation.		

# Electrical Connections

Figure 4. Layout Diagram

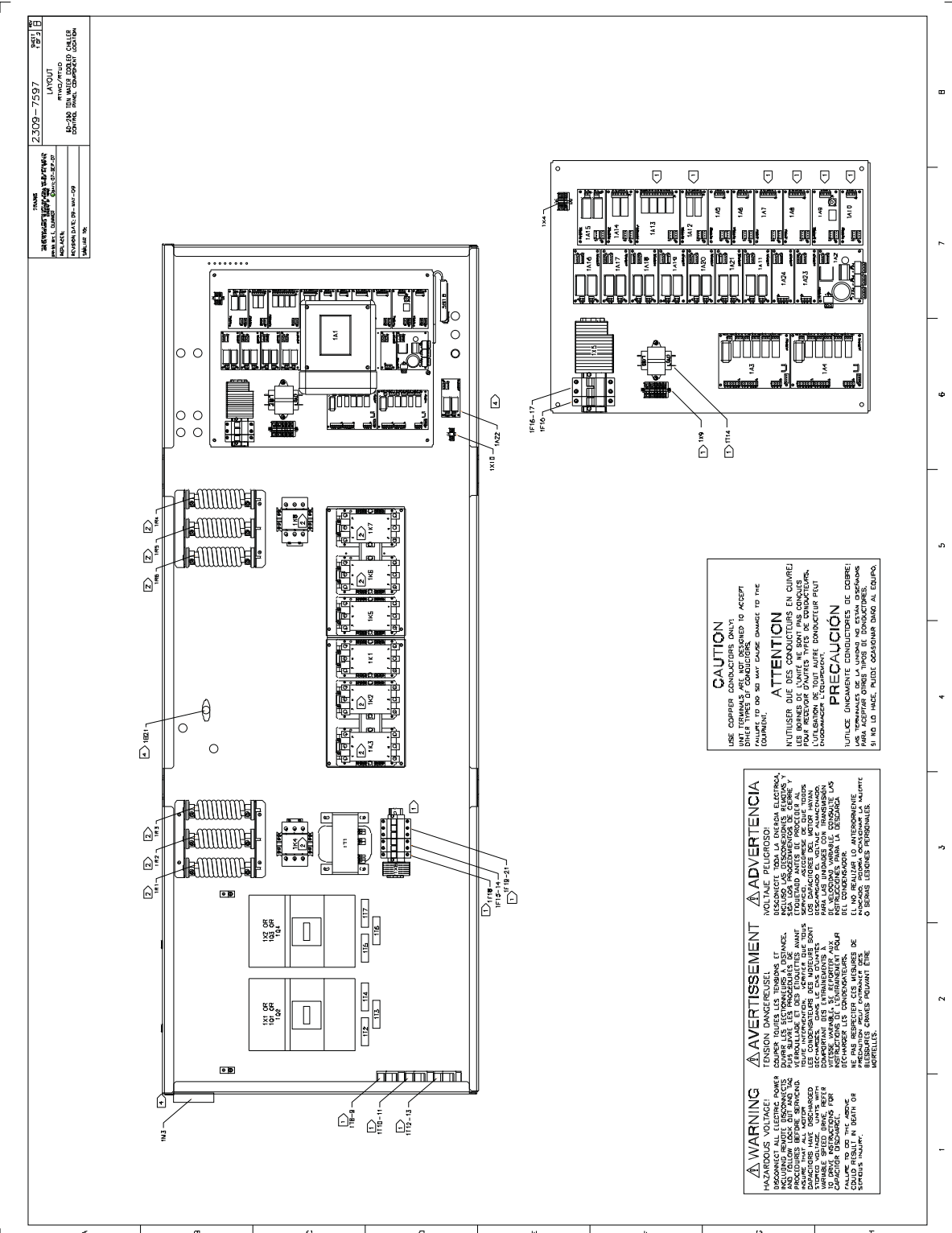

**CAUTION**  
 USE COPPER CONDUCTORS ONLY!  
 ONLY COPPER CONDUCTORS ARE PERMITTED TO ACCEPT FULL LOAD. FAILURE TO DO SO MAY CAUSE DAMAGE TO THE EQUIPMENT.

**ATTENTION**  
 N'UTILISER QUE DES FILS EN LAITON POUR RECEVOIR D'AUTRES TYPES DE CONDUCTEURS. SEULEMENT LES CONDUCTEURS EN LAITON SONT PERMIS POUR ACCEPTER LA CHARGE COMPLETE.

**PRECAUCION**  
 UTILICE UNICAMENTE CONDUCTORES DE COBRE! PARA RECEBIER OTROS TIPOS DE CONDUCTORES, SOLO SE PERMITEN LOS CONDUCTORES EN LAITON. SI NO SE HACE PODRIA OCASIONAR DAÑO AL EQUIPO.

**WARNING** **AVERTISSEMENT** **ADVERTENCIA**

**HAZARDOUS VOLTAGE!** **TENSION DANGEREUSE!** **NOTIASE PELIGROSO!**

BEFORE WORKING ON ELECTRICAL EQUIPMENT, DISCONNECT AND LOCKOUT THE MAIN POWER SUPPLY. BEFORE WORKING ON ELECTRICAL EQUIPMENT, DISCONNECT AND LOCKOUT THE MAIN POWER SUPPLY. BEFORE WORKING ON ELECTRICAL EQUIPMENT, DISCONNECT AND LOCKOUT THE MAIN POWER SUPPLY.

AVANT DE TRAVAILLER SUR L'EQUIPEMENT ELECTRIQUE, DEBRANCHER ET BLOQUER L'ALIMENTATION PRINCIPALE. AVANT DE TRAVAILLER SUR L'EQUIPEMENT ELECTRIQUE, DEBRANCHER ET BLOQUER L'ALIMENTATION PRINCIPALE. AVANT DE TRAVAILLER SUR L'EQUIPEMENT ELECTRIQUE, DEBRANCHER ET BLOQUER L'ALIMENTATION PRINCIPALE.

BEFORE WORKING ON ELECTRICAL EQUIPMENT, DISCONNECT AND LOCKOUT THE MAIN POWER SUPPLY. BEFORE WORKING ON ELECTRICAL EQUIPMENT, DISCONNECT AND LOCKOUT THE MAIN POWER SUPPLY. BEFORE WORKING ON ELECTRICAL EQUIPMENT, DISCONNECT AND LOCKOUT THE MAIN POWER SUPPLY.

AVANT DE TRAVAILLER SUR L'EQUIPEMENT ELECTRIQUE, DEBRANCHER ET BLOQUER L'ALIMENTATION PRINCIPALE. AVANT DE TRAVAILLER SUR L'EQUIPEMENT ELECTRIQUE, DEBRANCHER ET BLOQUER L'ALIMENTATION PRINCIPALE. AVANT DE TRAVAILLER SUR L'EQUIPEMENT ELECTRIQUE, DEBRANCHER ET BLOQUER L'ALIMENTATION PRINCIPALE.



**Table 24. Layout Notes**

1A1	Dyna View main processor interface	** 1K3	Contact, compressor 1A short.
1A2	Power supply module.	** 1K4	Contact, compressor 1A transition.
1A3	Starter module, compressor 1A.	1K5	Contact, compressor 2A start.
1A4	Starter module, compressor 2A.	** 1K6	Contact, compressor 2A run.
1A5	Dual low voltage input, external auto stop and emergency stop inputs.	** 1K7	Contact, compressor 2A short.
1A6	Dual low voltage input, external circuit lockout, refrigerant circuit 1 and 2.	** 1K8	Contact, compressor 2A transition.
* 1A7	Analog input/output, external current limit and external chilled water or hot water setpoint inputs.	* 1Q1	Disconnect switch, power distribution.
* 1A8	Analog input/output, condenser control and compressor % RLA output.	* 1Q2	Circuit breaker, power distribution.
* 1A9	Dual low voltage input, LCI-C communications (Echelon).	* 1Q3	Disconnect switch, power distribution.
* 1A10	Dual low voltage input, ice machine control and heat mode control.	* 1Q4	Circuit breaker, power distribution.
* 1A11	Dual high voltage input, motor thermostats compressor 2A and 1A.	** 1R1	Resistor, transition, compressor 1A, line A.
* 1A12	Dual relay output, ice making status.	** 1R2	Resistor, transition, compressor 1A, line B.
* 1A13	Quad relay outputs, unit status programmable relays.	** 1R3	Resistor, transition, compressor 1A, line C.
1A14	Dual relay output, condenser and chilled water pump relays.	** 1R4	Resistor, transition, compressor 2A, line A.
* 1A15	Dual high voltage input, condenser and chilled water flow and interlock.	** 1R5	Resistor, transition, compressor 2A, line B.
1A16	Dual triac output, modulating unload and load compressor 2A.	** 1R6	Resistor, transition, compressor 2A, line C.
1A17	Dual triac output, step load control compressor 2A and 1A.	1T1	Transformer, control power.
1A18	Dual triac output, modulating unload and load compressor 1A.	1T2	Transformer, current, compressor 1A, line A.
1A19	Dual high voltage input, high pressure cutout compressor 2A and 1A.	1T3	Transformer, current, compressor 1A, line B.
1A20	Dual triac output, oil return gas pump drain and fill, circuit 2.	1T4	Transformer, current, compressor 1A, line C.
1A21	Dual triac output, oil return gas pump drain and fill, circuit 1.	1T5	Transformer, current, compressor 2A, line A.
*** 1A22	Dual high voltage input, panel ventilation.	1T6	Transformer, current, compressor 2A, line B.
1A23	Dual low voltage input, oil loss level.	1T7	Transformer, current, compressor 2A, line C.
* 1A24	Dual low voltage input, water flow sensor.	* 1T8	Transformer, potential, under/over voltage - power meter, line A to B.
*** 1B21	Thermostat, panel ventilation	* 1T9	Transformer, potential, power meter, line B to C.
1F13	Fuse, potential transformer primary, compressor 1A, line A, under/over voltage - power meter.	* 1T10	Transformer, potential, power meter, line A to C.
1F14	Fuse, potential transformer primary, compressor 1A, line B, under/over voltage - power meter.	* 1T11	Transformer, potential, power meter, line A to B.
1F15	Fuse, control power transformer secondary, 115 V.	* 1T12	Transformer, potential, power meter, line B to C.
1F16	Fuse, control power transformer secondary, 27 V.	* 1T13	Transformer, potential, power meter, line A to C.
1F17	Fuse, control power transformer secondary, 27 V.	1T14	Transformer, potential, power meter, line A to B.
* 1F18	Fuse, potential transformer primary, compressor 1A, line C, power meter.	1X1	Power distribution block.
* 1F19	Fuse, potential transformer primary, compressor 2A, line A, power meter.	* 1X2	Power distribution block.
* 1F20	Fuse, potential transformer primary, compressor 2A, line B, power meter.	1X4	Terminal strip, customer control wiring.
* 1F21	Fuse, potential transformer primary, compressor 2A, line C, power meter.	1X5	Terminal strip, factory control wiring.
		* 1X6	Terminal strip, factory power meter wiring.
* 5B18	Temperature sensor, outdoor air temperature.	* 1X9	Terminal strip, factory control wiring.
1K1	Contact, compressor 1A start.	*** 1X10	Terminal strip, ventilation.
** 1K2	Contact, compressor 1A run.		

**Notes:**

\* - Optional components; may not be present on all units.

\*\* - Wye-delta components; may not be present on all units.

\*\*\* - Only present when ventilation is required.

Refer to RTWD electrical schematic for specific electrical connection information and notes pertaining to wiring installation.

# Dimensions

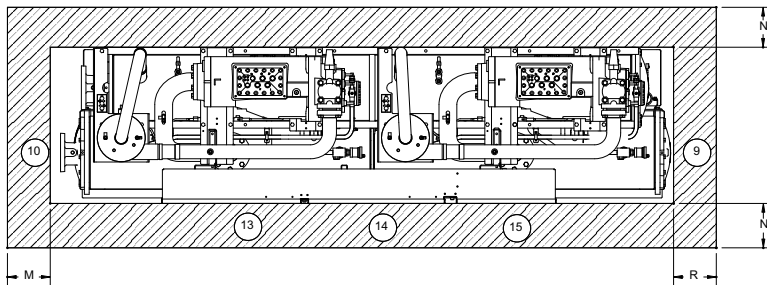
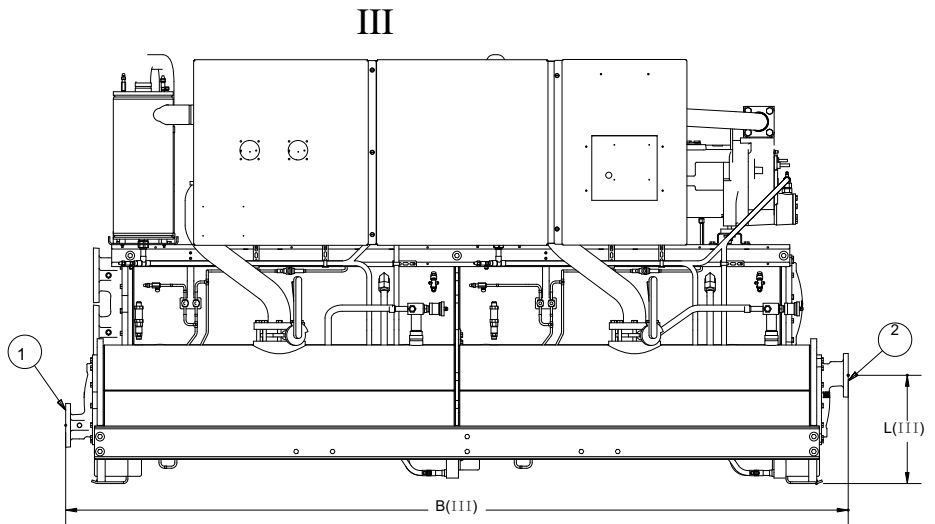
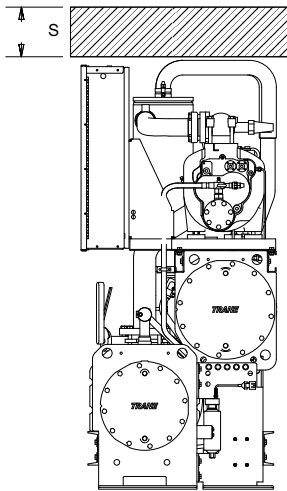
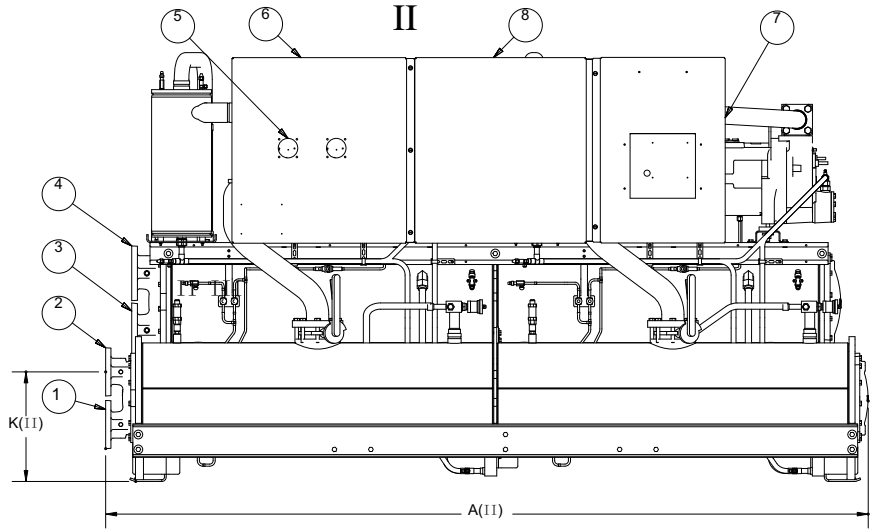
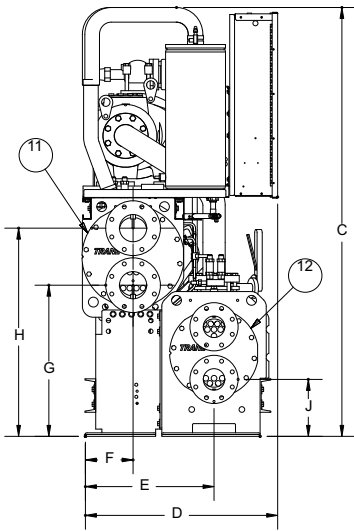

**Table 25. 50 Hz Dimensions - 70-150 ton SE, 60-120 ton HE**

RTWD	Standard Efficiency		High Efficiency	
	70,80,90,100,110 inch/mm	120,130,140,150 inch/mm	60,70,80 inch/mm	90,100,110,120 inch/mm
<b>A (2 pass evap)</b>	138.2/3510	126.4/3210	127.0/3225	127.0/3225
<b>B (3 pass evap)</b>	145.5/3620	145.5/3620	130.7/3320	130.7/3320
<b>C</b>	77.0/1955	76.9/1954	76.1/1933	76.1/1933
<b>D</b>	35.0/890	35.0/890	35.0/890	35.0/890
<b>E</b>	23.6/600	23.6/600	23.6/600	23.6/600
<b>F</b>	9.1/231	9.1/231	9.1/231	9.1/231
<b>G</b>	27.9/709	27.9/709	27.9/709	27.9/709
<b>H</b>	36.6/929	36.6/929	36.6/929	36.6/929
<b>J (2 pass evap)</b>	11.0/280	10.6/268	10.7/273	10.2/259
<b>J (3 pass evap)</b>	10.5/266	10.1/256	10.2/259	9.7/247
<b>K (2 pass evap)</b>	18.9/480	19.2/488	18.6/473	18.9/479
<b>L (3 pass evap)</b>	19.4/494	19.5/496	19.2/487	19.2/487
<b>M</b>	36.0/915	36.0/915	36.0/915	36.0/915
<b>N*</b>	36.0/915*	36.0/915*	36.0/915*	36.0/915*
<b>R</b>	126.7/3217	126.7/3217	114.8/3217	114.8/3217
<b>S</b>	36.0/915	36.0/915	36.0/915	36.0/915

Reference	
<b>1</b>	Evaporator Water Inlet
<b>2</b>	Evaporator Water Outlet
<b>3</b>	Condenser Water Inlet
<b>4</b>	Condenser Water Outlet
<b>5</b>	Power Disconnect
<b>6</b>	Power Wire
<b>7</b>	Control Wire
<b>8</b>	Control Panel
<b>9</b>	Condenser Return Waterbox End - Minimum Clearance (for tube removal)
<b>10</b>	Condenser Supply Waterbox End - Minimum Clearance (for maintenance)
<b>11</b>	Condenser
<b>12</b>	Evaporator
<b>13</b>	Panel Power Section (door swing 31.3 inch [796.9 mm])
<b>14</b>	Panel Power Section (door swing 31.3 inch [790.1 mm])
<b>15</b>	Panel Control Section (door swing 22.4 inch [568.14 mm])
<b>II</b>	2 Pass Evaporator Unit
<b>III</b>	3 Pass Evaporator Unit
<b>*</b>	42 inch (1067 mm) clearance required to other ground parts, two units with panels facing each other or other live parts require a clearance of 48 inch (1220 mm).

# Dimensions

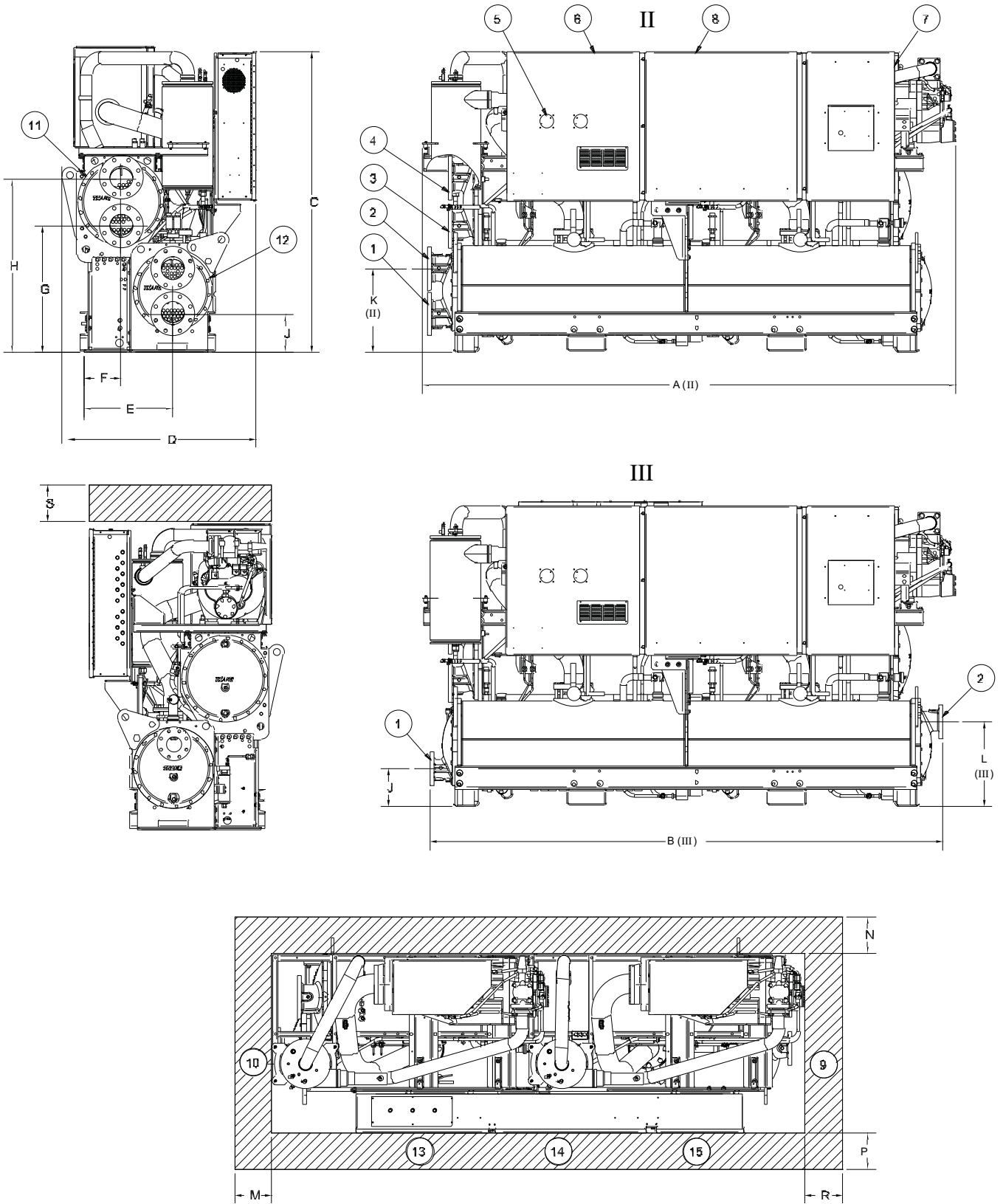

**Table 26. 50 Hz Dimensions - 130-250 ton HE, 160-200 ton PE**

RTWD	High Efficiency		Premium Efficiency	
	130, 140, 160, 180 inch/mm	200, 220, 250 inch/mm	160, 180 inch/mm	200 inch/mm
<b>A (2 pass evap)</b>	132.3/3360	136.1/3456	147.8/3755	136.7/3472
<b>B (3 pass evap)</b>	132.3/3360	136.1/3456	150.8/3831	136.7/3472
<b>C</b>	75.6/1920	76.9/1955	76.8/1950	76.9/1955
<b>D</b>	49.4/1256	49.9/1267	49.4/1256	49.9/1267
<b>E</b>	21.5/547	21.5/547	21.5/547	21.5/547
<b>F</b>	10.4/265	10.4/265	10.4/265	10.4/265
<b>G</b>	32.7/830	33.1/840	33.8/860	33.1/841
<b>H</b>	42.4/1078	43.9/1115	43.6/1108	43.9/1115
<b>J (2 pass evap)</b>	10.1/256	10.6/270	10.6/270	10.6/270
<b>J (3 pass evap)</b>	9.5/241	9.7/247	9.7/247	9.7/247
<b>K (2 pass evap)</b>	19.3/490	20.6/524	20.6/524	20.6/524
<b>L (3 pass evap)</b>	19.9/505	21.6/549	21.6/550	21.6/549
<b>M</b>	36.0/914	36.0/914	36.0/914	36.0/914
<b>N</b>	36.0/914	36.0/914	36.0/914	36.0/914
<b>P*</b>	40/1016*	40/1016*	40/1016*	40/1016*
<b>R</b>	114.8/2916	114.8/2916	134.5/3416	134.5/3416
<b>S</b>	36.0/914	36.0/914	36.0/914	36.0/914

**Reference**

<b>1</b>	Evaporator Water Inlet
<b>2</b>	Evaporator Water Outlet
<b>3</b>	Condenser Water Inlet
<b>4</b>	Condenser Water Outlet
<b>5</b>	Power Disconnect
<b>6</b>	Power Wire
<b>7</b>	Control Wire
<b>8</b>	Control Panel
<b>9</b>	Condenser Return Waterbox End - Minimum Clearance (for tube removal)
<b>10</b>	Condenser Supply Waterbox End - Minimum Clearance (for maintenance)
<b>11</b>	Condenser
<b>12</b>	Evaporator
<b>13</b>	Panel Power Section [door swing 31.3 inch (796.9 mm)]
<b>14</b>	Panel Power Section [door swing 31.1 inch (790.1 mm)]
<b>15</b>	Panel Control Section [door swing 22.4 inch (568.14 mm)]

**II** 2 Pass Evaporator Unit

**III** 3 Pass Evaporator Unit

Control panel clearance is 36 or 40 inch (914 or 1016 mm) depending on voltages, starter type, unit application and local code; 42 inch (1067 mm) clearance required to other grounded parts; two units with panels facing each other or other live parts require a clearance of 48 inch (1220 mm).

**\***

## Dimensions

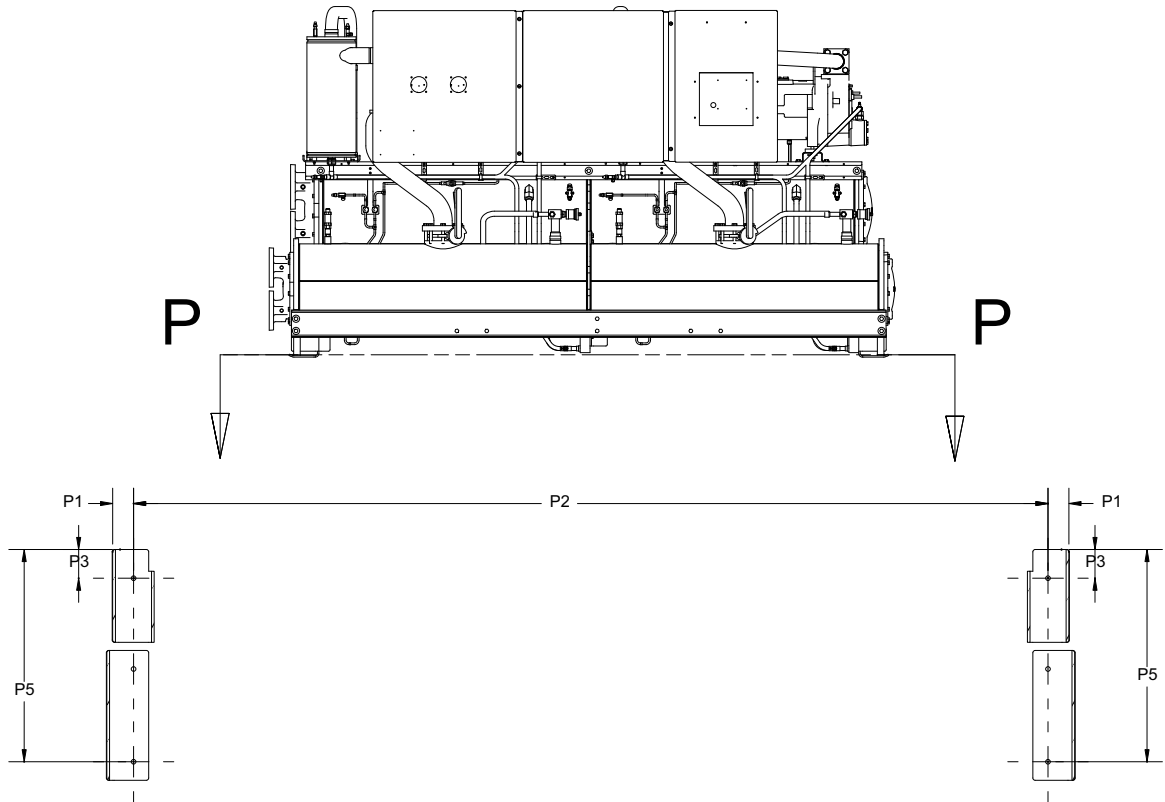

**Figure 5. RTWD unit footprint – all sizes**

	<b>Standard Efficiency 70-150 ton</b>	<b>High Efficiency 70-120 ton</b>	<b>High Efficiency 130-250 ton Premium Efficiency 200 ton</b>	<b>Premium Efficiency 160-180 ton</b>
	<b>inch/mm</b>	<b>inch/mm</b>	<b>inch/mm</b>	<b>inch/mm</b>
<b>P1</b>	2.9/73	2.9/73	2.9/73	2.9/73
<b>P2</b>	124.0/3150	112.0/2845	112.0/2845	131.7/3344
<b>P3</b>	3.9/99	3.9/99	4.3/109	4.3/109
<b>P4</b>	28.8/732	28.8/732	29.3/743	29.3/743

Note: Base hole diameters all 0.63 inch (16mm).

**Table 27. Weights - 50 Hz - I-P units**

Model	Standard Efficiency		High Efficiency		Premium Efficiency	
	Operating Weight (lbs)	Shipping Weight (lbs)	Operating Weight (lbs)	Shipping Weight (lbs)	Operating Weight (lbs)	Shipping Weight (lbs)
<b>60</b>	N/A	N/A	5706	5525	N/A	N/A
<b>70</b>	5874	5677	5724	5534	N/A	N/A
<b>80</b>	6030	5807	5893	5680	N/A	N/A
<b>90</b>	6187	5938	6319	6063	N/A	N/A
<b>100</b>	6268	6010	6412	6145	N/A	N/A
<b>110</b>	6332	6014	6495	6220	N/A	N/A
<b>120</b>	6903	6614	6914	6619	N/A	N/A
<b>130</b>	7337	7016	8188	7848	N/A	N/A
<b>140</b>	7342	7020	8256	7895	N/A	N/A
<b>150</b>	7395	7049	N/A	N/A	N/A	N/A
<b>160</b>	N/A	N/A	8353	7963	9072	8576
<b>180</b>	N/A	N/A	8770	8351	9579	9030
<b>200</b>	N/A	N/A	9740	9242	10042	9451
<b>220</b>	N/A	N/A	9778	9268	N/A	N/A
<b>250</b>	N/A	N/A	9943	9383	N/A	N/A

Note: All weights +/-3%.

Weights include optional base rail fork lifting, subtract 300 lbs if this option is not selected.



## Dimensions

**Table 28. Weights - 50 Hz - SI units**

Model	Standard Efficiency		High Efficiency		Premium Efficiency	
	Operating Weight (kg)	Shipping Weight (kg)	Operating Weight (kg)	Shipping Weight (kg)	Operating Weight (kg)	Shipping Weight (kg)
<b>60</b>	N/A	N/A	2588	2506	N/A	N/A
<b>70</b>	2664	2575	2596	2510	N/A	N/A
<b>80</b>	2735	2634	2673	2576	N/A	N/A
<b>90</b>	2806	2693	2866	2750	N/A	N/A
<b>100</b>	2843	2726	2908	2787	N/A	N/A
<b>110</b>	2872	2755	2946	2821	N/A	N/A
<b>120</b>	3131	3000	3136	3002	N/A	N/A
<b>130</b>	3328	3182	3714	3560	N/A	N/A
<b>140</b>	3330	3184	3745	3581	N/A	N/A
<b>150</b>	3354	3197	N/A	N/A	N/A	N/A
<b>160</b>	N/A	N/A	3789	3612	4115	3890
<b>180</b>	N/A	N/A	3979	3788	4345	4096
<b>200</b>	N/A	N/A	4418	4192	4555	4287
<b>220</b>	N/A	N/A	4435	4204	N/A	N/A
<b>250</b>	N/A	N/A	4510	4256	N/A	N/A

Note: All weights +/-3%.

Weights include optional base rail fork lifting, subtract 136.1 kg if this option is not selected.



# Mechanical Specifications

## General

Exposed metal surfaces are painted with air-dry beige, direct-to-metal, single-component paint. Each unit ships with full operating charges of refrigerant and oil. Molded elastomeric isolation pads are supplied for placement under all support points.

## Compressor and Motor

The unit is equipped with two semi-hermetic, direct-drive, 3000 rpm 50 Hz rotary compressors that include a load/unload valve, rolling element bearings, oil filtration device and heater. The motor is a suction gas-cooled, hermetically sealed, two-pole squirrel cage induction motor. Oil separator device is provided separate from the compressor. Check valves in the compressor discharge and lube oil system and a solenoid valve in the lube system are also provided.

## Unit-Mounted Starter

The unit is supplied with a IP-22 type enclosure with top power-wiring access and three-phase, overload protection. The starter is available in a wye-delta or across-the-line configuration, factory-mounted and fully pre-wired to the compressor motor and control panel. A factory-installed, factory-wired 820 VA control power transformer provides all unit control power (120 Vac secondary) and Trane CH530 module power (24 Vac secondary). Optional starter features include circuit breaker or mechanical, non-fused disconnect.

## Evaporator

Dual circuited, shell and tube falling film evaporator design is used. Seamless internally finned, copper tubes are mechanically expanded into tube sheets and mechanically fastened to tube supports. Evaporator tubes are 1.0 inch (25.4 mm) diameter on standard efficiency chillers and 0.75 inch (19.05 mm) diameter on high and premium efficiency chillers. All tubes can be individually replaced.

Shells and tube sheets are made of carbon steel. Designed, tested, and stamped in accordance with ASME and Chinese code. The evaporator is designed for refrigerant-side/working-side pressure of 200 psig (13.8 bars).

All water pass arrangements are available with flanged connections with 150 psig (10.5 bars) waterside working pressure. Waterside shall be hydrostatically tested at 225 psig (15.5 bars).

## Condenser

Dual circuited, shell and tube condenser designed with seamless internally/externally finned tubes expanded into tubesheets and mechanically fastened to tube supports. Condenser tubes are 1.0 inch (25.4 mm) diameter on standard efficiency chillers and 0.75 inch (19.05 mm) diameter on high and premium efficiency chillers. All tubes can be individually replaced.

Shells and tube sheets are made of carbon steel. Designed, tested, and stamped in accordance with ASME and Chinese code. The condenser is designed for refrigerant-side/working-side pressure of 300 psig (20.7 bars).

Water side has single inlet and outlet piping connection. All water pass arrangements are available with flanged connections with 150 psig (10.5 bars) waterside working pressure. Waterside shall be hydrostatically tested at 225 psig (15.5 bars).

Standard temperature condenser allow for leaving condenser water temperature up to 105°F (40.6°C) and for entering condenser water temperatures up to 95°F (35°C).

## Mechanical Specifications

---

### Refrigerant Circuit

Each unit has two refrigerant circuits, with one rotary screw compressor per circuit. Each refrigerant circuit includes compressor suction and discharge service valves, liquid line shut off valve, removable core filter, charging port and an electronic expansion valve. Modulating compressors and electronic expansion valves provide variable capacity modulation over the entire building load and maintain proper refrigerant flow.

### Oil Management

The RTWD is configured with an oil management system that ensures proper oil circulation throughout the unit. The key components of the system include an oil separator, oil filter and gas pump. An optional oil cooler is installed when the unit is used for high condensing temperature or low evaporator temperature conditions. For example, heat recovery, water-to-water heat pump, ice making and low temperature process applications.

### Unit Controls (Trane CH530)

The microprocessor-based control panel is factory-installed and factory-tested. The control system is powered by a pre-wired control power transformer, and will load and unload the chiller through adjustment of the compressor slide valve. Microprocessor-based chilled water reset based on return water is standard.

The Trane CH530 microprocessor automatically acts to prevent unit shutdown due to abnormal operating conditions associated with low evaporator refrigerant temperature, high condensing temperature, and/or motor current overload. If an abnormal operating condition continues and the protective limit is reached, the machine will shut down.

The panel includes machine protection shutdown requiring *manual reset* for the following conditions:

- Low evaporator refrigerant temperature and pressure
- High condenser refrigerant pressure
- Low oil flow
- Critical sensor or detection circuit faults
- Motor current overload
- High compressor discharge temperature
- Lost communication between modules
- Electrical distribution faults: phase loss, phase imbalance, or phase reversal
- External and local emergency stop
- Starter transition failure

The panel also includes machine protection shutdown with *automatic reset* for the following correctable conditions:

- Momentary power loss
- Under/over voltage
- Loss of evaporator or condenser water flow

When a fault is detected, the control system conducts more than 100 diagnostic checks and displays results. The display will identify the fault, indicate date, time, and operating mode at time of occurrence, and provide type of reset required and a help message.

## Clear Language Display Panel

Factory-mounted to the control panel door, the operator interface has an LCD touch-screen display for operator input and information output. This interface provides access to the following information: evaporator report, condenser report, compressor report, ASHRAE Guideline 3 report, operator settings, service settings, service tests, and diagnostics. All diagnostics and messages are displayed in clear un-coded language.

Data contained in available reports includes:

- Water and air temperatures
- Refrigerant levels and temperatures
- Oil pressure
- Flow switch status
- EXV position
- Head pressure control command
- Compressor starts and run-time
- Line phase percent RLA, amps, and volts

All necessary settings and setpoints are programmed into the microprocessor-based controller via the operator interface. The controller is capable of receiving signals simultaneously from a variety of control sources, in any combination, and priority order of control sources can be programmed. The control source with priority determines active setpoints via the signal it sends to the control panel. Control sources may be:

- Local operator interface (standard)
- Time of day scheduling (optional capability available from local operator interface)
- Hard-wired 4-20 mA or 2-10 Vdc signal from an external source (interface optional; control source not supplied)
- LonTalk™ LCI-C (interface optional; control source not supplied)
- Trane Tracer Summit™ system (interface optional; control source not supplied)

## Quality Assurance

The quality management system applied by Trane has been subject to independent third-party assessment and approval to ISO 9001. The products described in this catalog are designed, manufactured and tested in accordance with the approved system requirements described in the Trane Quality Manual.

# Options

## **Base Rail Forklifting**

Channels built into the base frame allow for easy movement using a forklift

## **Dual Relief Valve**

Unit comes with dual relief valves on both the high pressure side and low pressure side of each refrigerant circuit. Each dual relief valve configuration includes an isolation valve. Single relief valves are standard.

## **High-Temperature Condenser**

Optimized compressors, oil cooler and high condenser temperature control panel allows for leaving condenser water temperatures up to 140°F (60°C). This option is required for entering condenser water temperatures above 95°F (35°C).

## **Insulation**

The evaporator, water boxes, and motor housing are covered with factory installed 0.75 inch (19.05 mm) insulation. Factory installed foam insulation is used on the suction line, liquid level sensor, oil return system assembly (with its associated piping).

## **Insulation for High Humidity**

The evaporator and water boxes are covered with factory installed 1.5 inch (38.1 mm) insulation. Factory installed foam insulation is used on the motor housing, suction line, liquid level sensor, and oil return system assembly (with its associated piping).

## **Isolators**

Molded elastomeric isolators ship with the unit.

## **Low-Temperature Evaporator**

Optimized compressors and oil cooler enable evaporator operation down to minimum leaving water temperature of 10°F (-12.2°C).

## **Nitrogen Charge**

Unit is shipped with a nitrogen holding charge in lieu of refrigerant.

## **Performance Tests**

Performance tests are available to certify chiller performance before shipment.

## **Two-Way Condenser Water Regulating Valve**

For water regulation, a field-installed, 2-way butterfly-type (lug-style) valve, with integral electrical operator and factory-mounted valve actuator, is available. The single-phase, dual frequency, motor can be selected with 115 V (can be powered directly from control power transformer at unit) or 220 V power. The 2-way valve is field-wired and controlled by the chiller regulating valve control output. Valves are available in 3 and 4 inch (88.9 mm and 114.3 mm) sizes.

## **Water-to-Water Heat Pump**

Optimized compressors, oil cooler and high condenser temperature control panel allows for leaving condenser water temperatures up to 140°F (60°C). This option allows for entering condenser water temperatures above 95°F (35°C) Condenser leaving water temperature control option is required; the setpoint range is 80°F (26.7°C) to 140°F (60°C).

## Electrical Options:

### **Across-the-Line Starter**

Across-the-line starter is unit mounted with a IP-22 gasketed enclosure.

### **Wye-Delta Starter**

This option provides a reduced-inrush, unit mounted starter with a IP-22 gasketed enclosure.

### **Circuit Breaker**

A molded case standard interrupting capacity circuit breaker, factory pre-wired with terminal block power connections and equipped with a lockable external operator handle, is available to disconnect the chiller from main power.

### **Non-Fused Disconnect**

A non-fused molded case disconnect switch, factory pre-wired with terminal block power connections and equipped with a lockable external operator handle, is available to disconnect the chiller from main power.

### **Dual Point Power Connection**

Unit is available with either dual or single point power connections.

## **Control Options:**

### **Chilled Water Reset – Outdoor Air Temperature**

Controls, sensors, and safeties allow reset of chilled water temperature, based on temperature signal, during periods of low outdoor air temperature (chilled water reset based on return chilled water temperature is standard).

### **Condenser Leaving Water Temperature Control**

Enables the unit to use the leaving condenser water temperature to load and unload the chiller relative to the leaving condenser water setpoint. The control system allows for a condenser leaving temperature range of 80°F (26.7°C) to 140°F (60°C) with a water to water heat pump.

### **Condenser Differential Pressure Output**

Provides a 2–10 Vdc signal based on the system refrigerant differential pressure and time at the differential with customer defined endpoints.

### **Condenser Pressure (%HPC) Output**

Provides a 2–10 Vdc output that is a function of percent high pressure cutout for condenser pressure. The percent high pressure cutout for condenser pressure indication output is based on the condenser refrigerant pressure transducer(s).

### **Condenser Water Control Output**

Provides a highly configured signal designed to control a Trane supplied condenser water regulating valve.

### **External Chilled Water or Hot Water Setpoint**

External chilled or hot water setpoint signal can be field wired to a factory-installed, tested interface board through a 2–10 Vdc or 4–20 mA signal.

### **External Current-Limiting**

External current-limit setpoint is communicated to a factory-installed, tested communication board through a 2–10 Vdc or 4–20 mA signal.

### **LonTalk/Tracer Summit Interface**

LonTalk (LCI-C) or Tracer Summit communications capabilities are available, with communication link via single twisted-pair wiring to factory-installed, tested communication board.

### **Motor Current Analog Output**

Control system indicates the active chiller percent of full run load amps, based on a 0–10 Vdc.

### **Power Meter**

Tracks energy consumption (compressors only) with kWh meter.

### **Programmable Relays**

Predefined, factory-installed, programmable relays allow the operator to select four relay outputs. Available outputs are: Alarm-Latching, Alarm-Auto Reset, General Alarm, Warning, Chiller Limit Mode, Compressor Running, Head Pressure Relief Request, and Tracer Control.

### **Time of Day Scheduling**

Time of day scheduling capabilities are available for scheduling single chiller applications through Trane CH530 panel (without the need for building automation system-BAS). This feature allows the user to set up to 10 events in a 7 day time period.





**[www.trane.com](http://www.trane.com)**

*For more information, contact your local Trane office or e-mail us at [comfort@trane.com](mailto:comfort@trane.com)*

---

Literature Order Number	RLC-PRC032-EN
Date	October 2017
Supersedes	RLC-PRC032-EN (September 2009)

---

Trane has a policy of continuous product and product data improvement and reserves the right to change design and specifications without notice. Only qualified technicians should perform the installation and servicing of equipment referred to in this literature.